

A/F SERIES

Helisel Dişlilil Redüktör
Helical Geared Motors
Stirnradtriebemotoren
Motoriduttori Coassiali
Motoréducteurs Coaxiaux
Motorreductores Coaxiales

IE2 | IE3



Katalođumuzda yer alan bilgileri, önceden haber vermeksizin kısmen veya tamamen deđiřtirme veya iptal etme hakkını saklı tutmaktayız. /

We reserve the right to our company to make changes or modifications to catalogue without prior notice. /

Eine änderung in diesem Katalog der Technischen Werte sowie Daten und Mařen und Gewichte bleiben vorbehalten. /

Nous rėservons le droit à notre société d'apporter toutes sortes de changement ou modifications au catalogue sans préavis. /

Ci riserviamo il diritto di apportare cambiamenti o modifiche al catalogo senza preavviso. /

Nuestra compańía se reserva el derecho a realizar cambios o modificaciones a este catálogo sin previo aviso. /

PGR[®]
DRIVE TECHNOLOGIES



A series of horizontal dotted lines spanning the width of the page, providing a template for handwritten notes or a signature.

İÇİNDEKİLER / CONTENTS / INHALT / INDICE / INDEX / INDICE

Semboller / Symbols / Zeichen / Simbologia / Symboles / Simbologia	3
Teknik Bilgiler / Technical Information / Technische Informationen / Informazioni Tecniche / Informacion Tecnica / Informacion Técnico	4 - 7
Servis Faktörü / Service factor / Betriebsfaktor / Fattore di servizio / Facteur de service / Factor de servicio	8 - 9
Kritik Uygulamalar / Critical applications / Kritische anwendungen / Applicazioni critiche / Applications critiques / Aplicaciones Criticas	10 - 11
Termal Güç / Thermal Power / Thermische Leistung / Potenza termica / Puissance thermique / Potencia térmica	12 - 15
PAM B5 Flanşı ile Motor Montajı / Motor mounting with PAM flange B5 / Montage des moteurs an den PAM - Flansch B5 / Montaggio motore su flange B5 / Installation moteur sur bride PAM B5 / Montaje de motores con brida B5	16
IEC-PAM Bağlantılı / IEC-PAM Sleeve / IEC-PAM Buchse / Manicotto IEC-PAM / Manchon IEC-PAM / Manguito IEC-PAM	17
Montaj / Installation / Montage / Installazione / Installation / Instalación	18 - 19
Radial Yükler / Radial loads / Querbelastungen / Carichi radiali / Charges radiales / Cargas radiales	20 - 23
Atalet momentleri / Moments of inertia / Massenträgheitsmomente / Momenti d'inerzia / Moments d'inertie / Momentos de inercia	24
Yağlama / Lubrication / Schmierung / Lubrificazione / Lubrification / Lubricación	25 - 28
Montaj Pozisyonları / Mounting positions / Einbaulage / Piazzamento / Pos. de montage / Pos. de montaje	29 - 35
Modüler Sistem / Modularity / Modulares Baukastensystem / Modularità / Modularité / Modularidad	36
Ürünlerimiz / Products / Produkte / Prodotti / Produits / Productos	37
Redüktör seçim formu / Gearbox selection form / Formular für getriebeauswahl / Modulo di selezione riduttore / Formulaire de sélection de réducteurs / Formulario de selección del reductor	38 - 43
Sipariş örneği / Example for ordering / Beispiel bestellbeschreibung / Esempio di ordinazione / Exemple de commande / Ejemplo orden de compra	44
Tasarım / Designation / Bezeichnung / Designazione / Désignation / Designación	45
Kullanılan Terimler / Nomenclature / Nomenklatur / I termini usati / Les termes utilisés / Los términos utilizados	46
Aksesuarlar / Accessories / Zubehör / Accessori / Accessoires / Accesorios	47
Motorlu Seçim Tabloları / Selection Tables of Gearedmotors / Auswahltable von Getriebemotoren / Tabella di selezione di motorriduttori / Tableau de sélection du motoreducteurs / Tabla de selección de motorreductores	49 - 112
Ölçü Tabloları / Dimension Tables / Maßstabellen / Dimensione Tabelle / Tables de Dimension / Tablas de Dimensiones	113 - 145
W - IEC - PAM Adaptörü Seçim Tabloları / Selection Tables of W - IEC and PAM Adapters / Auswahltable von W - PAM - IEC Adapters / Tabella di selezione di W - PAM - IEC Adattatore / Tableau de sélection du W - PAM - IEC Adaptateur / Tabla de selección de W - PAM - IEC Adaptador	147 - 158
Genel Parça Listesi / General Part List / Allgemeine Stuckliste / Generale Elenco Delle Parti / Générale la liste des pièces / Lista de Piezas en General	160 - 172
Elektrik Motoru / Electric Motors / Elektromotoren / Motori elettrici / Moteurs électriques / Motores eléctricos	173 - 202
Motor parça listesi / Motor parts list / Ersatzteilliste Für Motor / Elenco Parti Motore / Liste Des Pièces Du Moteur / Lista De Piezas Del Motor	203 - 208
Fren parça listesi / Brake parts list / Bremse teil list / Elenco delle parti freno / Liste des pièces de frein / Lista de piezas de freno	209



A large area of the page filled with horizontal dotted lines, intended for writing or drawing.

TR SEMBOLLER
IT SIMBOLOGIA

EN SYMBOLS
FR SYMBOLES

DE ZEICHEN
ES SIMBOLOGIA

Semboller

P = Güç	(kW)	1 = Giriş Şaftı
M = Moment	(Nm)	2 = Çıkış Şaftı
n = Devir	(d/d)	R = Radyal
i = Tahvil Oranı		A = Eksenel
F = Kuvvet	(N)	s = Statik
m = Ağırlık	(kg)	d = Dinamik
f_B = Servis Faktörü		max = Maksimum
		min = Minimum

Symbols

P = Power	(kW)	1 = Input shaft
M = Torque	(Nm)	2 = Output shaft
n = Speed	(rpm)	R = Radial
i = Reduction ratio		A = Axial
F = Load	(N)	s = Static
m = Weight	(kg)	d = Dynamic
f_B = Service factor		max = Maximum
		min = Minimum

Zeichen

P = Leistung in	(kW)	1 = Antriebswelle
M = Drehmoment in	(Nm)	2 = Abtriebswelle
n = Drehzahl in	(rpm)	R = Radial
i = Übersetzung		A = Axial
F = Kraft in	(N)	s = Statisch
m = Masse in	(kg)	d = Dynamisch
f_B = Betriebsfaktor		max = Maximal
		min = Minimal

Simbologia

P = Potenza	(kW)	1 = Albero ingresso
M = Momento torcente	(Nm)	2 = Albero uscita
n = Numero giri	(giri / 1')	R = Radiale
i = Rapporto di riduzione		A = Assiale
F = Forza	(N)	s = Statico
m = Peso	(kg)	d = Dinamico
f_B = Fattore di servizio		max = Massimo
		min = Minimo

Symboles

P = Puissance	(kW)	1 = Arbre d'entrée
M = Moment de torsion	(Nm)	2 = Arbre de sortie
n = Nombre de tours	(tours/min)	R = Radial
i = Rapport de réduction		A = Axial
F = Force	(N)	s = Statique
m = Poids	(kg)	d = Dynamique
f_B = Facteur de service		max = Maximum
		min = Minimum

Simbologia

P = Potencia	(kW)	1 = Eje de entrada
M = Momento torsor	(Nm)	2 = Eje de salida
n = Número de revoluciones	(rpm)	R = Radial
i = Relación de reducción		A = Axial
F = Fuerza	(N)	s = Estático
m = Peso	(kg)	d = Dinámico
f_B = Factor de servicio		max = Máximo
		min = Mínimo

TR

TEKNİK BİLGİLER

Doğru ürünü seçebilmek için, Redüktörün belirlenmiş olan verilerinin bilinmesi gerekir

A. Redüktörün giriş devri (n1) ve istenilen çıkış devri (n2), ise verilmesi gereken tahvil (i) tahvil formülü ile hesaplanır:

$$i = \frac{n1}{n2}$$

B. Kullanılacak yer için istenilen Moment bilinmeli ve böylece redüktör seçimine devam edebilirsiniz.

Redüktör seçimi

Bu kılavuz size birkaç adımda doğru redüktör seçiminde yardımcı olacaktır.

1. Kullanılacak uygulamalarda Servis faktörünün (fb) belirlenmesi; Servis faktörünün belirlenmesi redüktörün kullanımına bağlı, yani hareket ettirdiği makinenin yük tipi, bir saatteki start-stop sayısı ve çalışma saatidir ("servis faktörü" S.8-9 bkz).
2. Giriş gücü (PH) gerekli olan Moment (MH), çıkış devri n2 ve dinamik verimlilik derecesini bilmek gerekir. Dinamik verimlilik değeri redüktörün tipi ve dişli kademelerine bağlıdır.
A/F serisi Helisel dişli redüktörlerde verim (ηd) yaklaşık olarak:
A/F..1 kademe = 0,97
A/F..2 kademe = 0,96
A/F..3 kademe = 0,94

$$PH = \frac{MH \cdot n2}{9550 \cdot \eta d}$$

3. Tablodan Redüktör için Normlanmış güç P1, gerekli olan PH den daha yüksek olacak şekilde seçiniz, böylece:

$$P1 \geq PH$$

4. Motorlu redüktörler için belirlenmiş standart güçler ile redüktörü seçebilirsiniz. İstenilen çıkış devrine yakın olan değer seçilir. Fakat servis faktörü istenilen ile aynı, veya daha büyük olmalıdır. (Kullanım alanı için gerekli olan servis faktörü fb)

Motorlu seçim sayfalarında, verilen değerler 50Hz'de 4 ve 6 kutuplu motorları içermektedir. Diğer motor devirleri için motorların nominal verilerini gözönüne alınız.

EN

TECHNICAL INFORMATION

For correctly selecting a gear reducer or geared motor, several essential pieces of data are required:

A- The rotational input speed to the gear reducer (n1) and the rotational output speed (n2). Through these two values it is possible to calculate the reduction ratio (i) of the gear reducer using the following formula:

$$i = \frac{n1}{n2}$$

B. The torque required by the application (MH) The geared motor or gear reducer can be chosen this data is known.

Geared motor selection

This guide indicates a brief sequence of steps for selecting a suitable product:

1. Determine the application's actual service factor (fb) This parameter depends on the type of load of the powered machine, the number of starts per hour and the hours of operation (refer to the "Service factor" paragraph on page 8-9)
2. Calculate the input power PH using the required torque value MH, the speed n2 and dynamic efficiency value. The dynamic efficiency value depends on the type of gear reducer and on the number of gear reduction stages. A/F-range helical gear reducers have an average value equal to: (ηd)
A/F..1 stages = 0,97
A/F..2 stages = 0,96
A/F..3 stages = 0,94

$$PH = \frac{MH \cdot n2}{9550 \cdot \eta d}$$

3. Consult the geared motor performance tables and identify a normalised power value P1 exceeding the required power PH, such that:

$$P1 \geq PH$$

4. Once the suitable normalised power has been identified, select the geared motor capable of generating the rotational speed closest to the desired n2 value and with service factors fb greater or equal to that required by the application.

In the geared motor selection tables the combinations include 2-pole, 4-pole and 6-pole motors powered at 50Hz; for different drive speeds refer to the nominal data provided for the gear reducers.

DE

TECHNISCHE INFORMATIONEN

Für die korrekte Auswahl eines Getriebes oder eines. Getriebemotors müssen einige grundsätzliche Daten bekannt sein:

A- Die Antriebsdrehzahl am Getriebeeingang (n1) und die gewünschte Abtriebsdrehzahl (n2). Mit diesen beiden Werten kann das Übersetzung - sverhältnis (i) des Getriebes mit der folgenden Formel ausgerechnet werden:

$$i = \frac{n1}{n2}$$

B. Das für die Anwendung erforderte Drehmoment (MH) Wenn diese Daten bekannt sind, kann mit der Auswahl des Getriebemotors oder des Getriebes fortgefahren werden.

Auswahl der Getriebe

Dieser Ratgeber führt in wenigen Schritten durch die Auswahl des geeigneten Getriebes:

1. Den Betriebsfaktor (fb) der Anwendung bestimmen. Dieser Parameter ist eine Funktion aus der Belastungsart der angetriebenen Maschine, der Anzahl der Anläufe pro Stunde und der Betriebsstundenzahl (siehe Absatz "Betriebsfaktor" S.8-9)
2. Die Eingangsleistung PH über das erforderliche Drehmoment MH, die Abtriebsdrehzahl n2 und den dynamischen Wirkungsgrads ermitteln. Der Wert des dynamischen wirkungsgrads hängt von der Art des Getriebes und von der Anzahl der Übersetzungsstufen ab. Für die Stirnradgetriebe der Serie A/F gilt ein mittlerer Wert von 0,9 (ηd)
A/F..1 Übersetzungsstufen = 0,97
A/F..2 Übersetzungsstufen = 0,96
A/F..3 Übersetzungsstufen = 0,94

$$PH = \frac{MH \cdot n2}{9550 \cdot \eta d}$$

3. Eine genormte Leistung P1 aus der Tabelle der Getriebemotorenleistungen aussuchen, die höher ist als die erforderliche PH, sodass:

$$P1 \geq PH$$

4. Nach dem Ermitteln der geeigneten genormten Leistung den Getriebemotor auswählen, der die Abtriebsdrehzahl zur Verfügung stellt, die der gewünschten n2 am nächsten kommt und der einen gleich hohen oder größeren Betriebsfaktor fb besitzt als durch die Anwendung gefordert.

In den Auswahl tabellen der Getriebemotoren sind die Kombinationen mit 50Hz - Motoren mit 2, 4 o der 6 Polen dargestellt. Für abweichende Antriebsgeschwindigkeiten berücksichtigen Sie bitte die Daten aus den Getriebetabellen.

IT INFORMAZIONI TECNICHE

Per la corretta selezione di un riduttore o di un motorriduttore occorre disporre di alcuni dati fondamentali quali:

A- La velocità angolare in entrata al riduttore (n1) e la velocità angolare in uscita (n2). Attraverso questi due valori è possibile calcolare il rapporto di riduzione (i) del riduttore attraverso la formula:

$$i = \frac{n1}{n2}$$

B. Il momento torcente richiesto dall'applicazione (MH). Noti questi dati, si può procedere nella selezione del motorriduttore o del riduttore.

Selezione dei motorriduttori

Questa guida conduce alla selezione del prodotto attraverso pochi passi:

1. Determinare il fattore di servizio effettivo dell'applicazione (fs). Questo parametro è funzione del tipo di carico della macchina azionata, del numero di azionamenti per ora e del numero di ore di funzionamento (vedi paragrafo "Fattore di servizio" pag. 8-9).
2. Ricavare la potenza in entrata PH mediante il momento torcente richiesto MH, la velocità n2 e il rendimento dinamico.
Il valore di rendimento dinamico dipende dalla tipologia del riduttore e dal numero di stadi d'ingranaggi di riduzione. I riduttori coassiali della serie A/F presentano un valore medio pari a: (ηd)
A/F..1 stadi = 0,97
A/F..2 stadi = 0,96
A/F..3 stadi = 0,94

$$PH = \frac{MH \cdot n2}{9550 \cdot \eta d}$$

3. Consultare le tabelle delle prestazioni dei motorriduttori ricercando una potenza normalizzata P1 superiore a quella richiesta PH tale che:

$$P1 \geq PH$$

4. Individuata la potenza normalizzata idonea, selezionare dunque il motorriduttore in grado di sviluppare la velocità angolare più vicina a quella n2 desiderata e con fattore di servizio fs maggiore o uguale richiesto dall'applicazione.

Nelle tabelle di selezione dei motorriduttori gli abbinamenti sono realizzati con motori 2,4,6 poli alimentati a 50Hz, per velocità di azionamento diverse riferirsi ai dati nominali forniti per i riduttori.

FR INFORMACION TECNICA

Pour choisir correctement un réducteur ou un motoréducteur, il est nécessaire de disposer de certaines données fondamentales telles que:

A- La vitesse angulaire en entrée du réducteur (n1) et la vitesse angulaire en sortie (n2). Grâce à ces deux valeurs, il est possible de calculer le rapport de réduction (i) du réducteur en utilisant la formule:

$$i = \frac{n1}{n2}$$

B. Le moment de torsion requis par l'application (MH). Une fois ces données, il est possible de procéder au choix du motoréducteur ou du réducteur.

Selection des motoréducteur

Ce guide permet de procéder à la sélection du produit en suivant quelques étapes:

1. Déterminer le facteur de service effectif de l'application (fs). Ce paramètre dépend du nombre d'actionnements par heure et du nombre d'heures de fonctionnement (voir paragraphe "Facteur de service" page 8-9).
2. Déterminer la puissance en entrée PH à l'aide du moment de torsion requis MH de la vitesse n2 et du rendement dynamique.
La valeur du rendement dynamique dépend du type de réducteur et du nombre de trains d'engrenages de réduction. Les réducteurs coaxiaux de la série A/F présentent une valeur moyenne égale à: (ηd)
A/F..1 trains = 0,97
A/F..2 trains = 0,96
A/F..3 trains = 0,94

$$PH = \frac{MH \cdot n2}{9550 \cdot \eta d}$$

3. Consulter le tableau des performances des motoréducteurs en recherchant une puissance normalisée PH supérieure la puissance P1 demandée telle que:

$$P1 \geq PH$$

4. Une fois identifiée la puissance normalisée adéquate, sélectionner le motoréducteur en mesure de développer la vitesse angulaire la plus proche de la vitesse n2 désirée et présentant un facteur de service fs supérieur ou égal à celui demandé par l'application.

Dans les tableaux de sélection des motoréducteurs, les combinaisons sont réalisées avec des moteurs 2,4,6 pôles alimentés à 50Hz. Pour des vitesses d'actionnement différentes, se référer aux données nominales fournis par les réducteurs

ES INFORMACIÓN TÉCNICO

Para la correcta selección de un reductor o de un motorreductor es necesario disponer de algunos datos fundamentales como:

A- La velocidad angular a la entrada del reductor (n1) y la velocidad angular a la salida (n2). A través de reducción (i) del reductor utilizando la fórmula:

$$i = \frac{n1}{n2}$$

B. El momento de torsión requerido por la aplicación (MH). Conocidos estos datos, se puede proceder a la selección del motorreductor o del reductor.

Selección de los motorreductores

Esta guía conduce a la selección del producto a través de unos pocos pasos:

1. Determinar el factor de servicio efectivo de la aplicación (fs). Este parámetro es función del tipo de carga de la máquina accionada, del número de accionamientos por hora y de la cantidad de horas de funcionamiento (ver el párrafo "Factor de servicio" pág. 8-9)
2. Obtener la potencia a la entrada PH utilizando el momento de torsión requerido MH, la velocidad n2 el rendimiento dinámico.
El valor del rendimiento dinámico depende del tipo de reductor y del número de etapas de engranajes de reducción. Los reductores coaxiales de la serie A/F presentan un valor medio igual a:
A/F..1 trenes = 0,97
A/F..2 trenes = 0,96
A/F..3 trenes = 0,94

$$PH = \frac{MH \cdot n2}{9550 \cdot \eta d}$$

3. Consultar las tablas de las prestaciones de los motorreductores buscando una potencia normalizada P1 superior a la requerida PH tal que:

$$P1 \geq PH$$

4. Una vez identificada la potencia normalizada adecuada, seleccionar el motorreductor capaz de desarrollar la velocidad angular más cercana a la n2 deseada y con un factor de servicio fs mayor o igual que el necesario para la aplicación

En las tbles de selección de los motorreductores, las combinaciones se realizan con motores de 2,4,6 polos alimentados con 50Hz. Para velocidades de accionamiento diferentes, consultar los datos nominales suministrados para los reductores.

TR

TEKNİK BİLGİLER

Redüktör seçimi

1. Uygulama alanı için servis faktörünü (f_b) belirleyiniz. (Sayfa 8-9 "servis faktörü" bakınız)
2. Giriş (n_1) ve çıkış (n_2) devirlerinden hesaplanan tahvilin belirlenmesi.

$$i = \frac{n_1}{n_2}$$

3. Redüktörün momenti ve uygulama için gerekli olan moment ve servis faktörünü belirleyiniz.

$$MG = MH \cdot (f_b)$$

4. İstemiş olduğunuz tahvile ve moment (M_2) değerine yakın olan redüktörü performans tablolarından seçiniz. Böylece;

$$M_2 \geq MG$$

Kontrol ediniz

Redüktör veya motorlu redüktör seçiminden sonra, altta sıralanmış maddeleri kontrol etmenizi tavsiye ederiz.

A. Termik Güç

Redüktörün termik gücü mekanik güç ile aynı ve daha büyük olmalıdır veya uygulamaya uygun olarak verilen değerler kısmında belirlenmiş verilere uygun olmalı (Sayfa 12-15 termik güç kısmına bakınız)

B. Maximum Moment

Redüktöre uygulanabilen genelde maximum moment (Anlık pik moment), %200 den daha fazla olmamalıdır.

C. Radyal Yük

Lütfen giriş ve çıkış millerinde radyal yüklerin katalog değerlerinin dışına çıkmaması için kontrol ediniz. Eğer yük daha büyük ise redüktörün büyüklüğünü ona göre seçiniz veya dış yükü ona göre uygulayınız. Kontrol aşamasında katalogta verilen radyal yüklerin çıkış millerinin orta noktasına geldiğine dikkat ediniz. Bu nedenle yükü uygun formüller ile istenilen pozisyona getirmeniz gerekir. Eğer yük pozisyonunuz uygun değil ise sayfa 20-23 "Radyal yükler" kısmına bakınız.

EN

TECHNICAL INFORMATION

Gear reducer selection

1. Determine the application's service factor (f_b) (consult to the "Servico factor" paragraph on page 8-9).
2. Calculate the reduction ratio i from the requested output speed n_2 and from the input speed n_1 .

$$i = \frac{n_1}{n_2}$$

3. Calculate the torque MG for selecting the gear reducer through the torque required by the application MH and the service factor f_b :

$$MG = MH \cdot (f_b)$$

4. Consult the gear reducer performance tables and identify the gear reducer that - with a reduction ratio closest to the calculated ratio - has a nominal torque M_2 such that

$$M_2 \geq MG$$

Checks

Once the gear reducer or geared motor has been selected, the following checks should be performed:

A Thermal Power

The gear reducer's thermal power must be equal to or greater than the installed mechanical power, or the power required by the application according to the indications contained in the section (refer to the "Thermal power" paragraph on page 12-15).

B Maximum Torque

Generally, the maximum torque (peak instantaneous load) that can be applied to the gear reducer must not exceed 200% of the nominal torque M_2 .

C Radial Loads

Verify that the loads acting on the input and /or output shaft are within with the values indicated in the catalogue. If they exceed these values, increase the size of the gear reducer or modify the external load capacity. During the checking phase, it is important to remember that the values indicated in the catalogue refer to loads acting on the mid-point of the shaft protrusion, therefore, if the load is applied to a different position, appropriate formulas must be used to calculate the admissible load in the desired position (refer to the "Radial loads" paragraph on page 20-23).

DE

TECHNISCHE INFORMATIONEN

Auswahl der Getriebe

1. Den Betriebsfaktor (f_b) der Anwendung bestimmen (siehe Absatz "Betriebsfaktor" S.8-9).
2. Das benötigte Übersetzungsverhältnis i aus der erforderlichen Abtriebsdrehzahl n_2 und der Antriebsdrehzahl n_1 bestimmen.

$$i = \frac{n_1}{n_2}$$

3. Das Drehmoment MG für die Auswahl des Getriebes über das von der Anwendung erforderliche Drehmoment MH und den Betriebsfaktor f_b ermitteln:

$$MG = MH \cdot (f_b)$$

4. Das Getriebe mit dem Übersetzungsverhältnis aus der Tabelle der Getriebedaten auswählen, das dem bestimmten Übersetzungsverhältnis am nächsten kommt und über ein ausreichendes Nenndrehmoment M_2 verfügt, sodass:

$$M_2 \geq MG$$

Überprüfungen

Nach der Auswahl des Getriebes oder des Getriebemotors ist es ratsam, die folgenden Überprüfungen durchzuführen:

A Thermische Leistung

Die thermische Leistung des Getriebes muss gleich oder größer als die installierte mechanische Leistung sein oder als die von der Anwendung gemäß den im Abschnitt enthaltenen Angaben erforderliche Leistung (siehe Abschnitt "thermische Leistung" S.12-15).

B Maximales Drehmoment

Grundsätzlich darf das maximale Drehmoment (momentane Spitzenbelastung), das an das Getriebe angewendet werden kann, nicht mehr als 200% des Nenndrehmoments M_2 betragen.

C Radiale Belastungen

Überprüfen Sie bitte, dass die radialen Belastungen auf den Eingangs- und/oder Ausgangswellen die zugelassenen Katalogwerte nicht überschreiten. Wenn diese größer sind, bitte die Getriebegröße anpassen oder die Auslegung für die externe Last anpassen. In der Prüfphase bitte berücksichtigen dass die im Katalog angegebenen Werte sich auf Lasten beziehen, die auf die Mittelachse des Wellenüberstands wirken. Daher ist es notwendig mit den entsprechenden Formeln die zugelassene Last in der gewünschten Position zu bestimmen. Falls diese in einer davon abweichenden Position angebracht wird, siehe Absatz "Radiale Belastungen S. 20-23.

IT INFORMAZIONI TECNICHE

Selezione dei riduttori

1. Determinare il fattore di servizio dell'applicazione (f_b) (vedi paragrafo "Fattore di servizio" pag.8-9)
2. Calcolare il rapporto di riduzione i dalla velocità in uscita n_2 richiesta e dalla quella in entrata n_1 .

$$i = \frac{n_1}{n_2}$$

3. Ricavare il momento torcente MG per la selezione del riduttore attraverso la coppia richiesta dall'applicazione MH ed il fattore di servizio f_b :

$$MG = MH \cdot (f_b)$$

4. Consultare le tabelle delle prestazioni dei riduttori cercando il riduttore che, col rapporto di riduzione più prossimo a quello calcolato, dispone di una coppia nominale M2 tale che:

$$M2 \geq MG$$

Verifiche

Esguita la selezione del riduttore o del motoriduttore è opportuno effettuare le seguenti verifiche:

A Potenza Termica

La potenza termica del riduttore deve essere uguale o maggiore della potenza meccanica installata o della potenza richiesta dall'applicazione secondo le indicazioni contenute nella sezione (vedi paragrafo "Potenza termica" pag 12-15).

B Coppia Massima

Generalmente la coppia massima (picco di cario istantaneo) che può essere applicata al riduttore non deve superare il 200% della coppia nominale M2.

C Carichi radiali

Verificare che i carichi radiali agenti sugli alberi di entrata e/o di uscita rispettino i valori ammessi a catalogo. Se superiori, aumentare la grandezza del riduttore o modificare la supportazione del carico esterno.

Nella fase di verifica occorre tenere conto che i valori indicati a catalogo si riferiscono a carichi agenti sulla mezzeria della sporgenza dell'albero per cui, nel caso il carico sia applicato in posizione deversa è necessario determinare con le apposite formule il carico ammissibile nella posizione desiderata (vedi paragrafo "Carichi Radiali" pag 20-23).

FR INFORMACION TECNICA

Sélection des réducteurs

1. Déterminer le facteur de service de l'application (f_b) (voir paragraphe "Facteur de service" page 8-9).
2. Calculer le rapport de réduction (i) à partir de la vitesse n_2 requise en sortie et de la vitesse en entrée n_1

$$i = \frac{n_1}{n_2}$$

3. Déterminer le moment de torsion MG pour la sélection du réducteur à l'aide du couple MH requis par l'application et du facteur de service f_b :

$$MG = MH \cdot (f_b)$$

4. Consulter les tableaux des performances des réducteurs en recherchant le réducteur disposant du rapport de réduction le plus proche du rapport calculé et présentant un couple nominal M2 tel que:

$$M2 \geq MG$$

Vérifications

Une fois sélectionné le réducteur ou le motoréducteur, il convient d'effectuer les vérifications suivantes:

A Puissance Thermique

La puissance thermique doit être égale ou supérieure à la puissance mécanique installée, ou à la puissance requise par l'application, conformément aux indications contenues dans la section (voir paragraphe "Puissance thermique" page 12-15).

B Couple Maximal

Généralement, le couple maximal (pic de charg instantané) pouvant être appliqué au réducteur, ne doit pas dépasser 200% du couple nominal M2.

C Charges Radiales

Vérifier que les charges radiales agissant sur les arbres d'entrée et/ou de sortie respectent les valeurs admises dans le catalogue. Si elles sont supérieures, augmenter la taille du réducteur ou modifier le palier de la charge extérieure.

Durant la phase de vérification, il est nécessaire de tenir compte du fait que les valeurs indiquées dans le catalogue se réfèrent à des charges agissant sur la moitié de la partie saillante de l'arbre; par conséquent, en cas d'application de la charge dans une position différente, il est nécessaire de déterminer la charge admissible dans la position désirée à l'aide des formules spéciales (voir paragraphe "Charges radiales" page 20-23)

ES INFORMACIÓN TÉCNICO

Selección de los reductores

1. Determinar el factor de servicio de la aplicación (f_b) (ver el párrafo "Factor de servicio" pág.8-9).
2. Calcular la relación de reducción i entre la velocidad de salida n_2 requerida y la de entrada n_1

$$i = \frac{n_1}{n_2}$$

3. Obtener el momento de torsión MG para seleccionar el reductor a través del par necesario para la aplicación MH y el factor de servicio f_b :

$$MG = MH \cdot (f_b)$$

4. Consultar las tables de las prestaciones de los reductores buscando el reductor que, con la relación de reducción más próxima a la calculada, disponga de un par nominal M2 tal que:

$$M2 \geq MG$$

Verificaciones

Una vez realiza la selección del reductor o del motorreductor es conveniente efectuar las siguientes verificaciones:

A Potencia Térmica

La potencia térmica del reductor debe ser mayor o igual que la potencia mecánica instalada o que la potencia requerida por la aplicación según las indicaciones contenidas en la sección (ver el párrafo "Potencia térmica" pág 12-15).

B Par Máximo

Generalmente el par máximo (pico de carga instantáneo) que se puede aplicar al reductor no debe superar el 200% del par nominal M2.

C Cargas Radiales

Verificar que las cargas radiales que actúan sobre los árboles de entrada y/o de salida respeten los valores admitidos según el catálogo. Si son mayores, aumentar el tamaño del reductor o modificar la capacidad de soportar la carga externa. En la fase de verificación, es necesario tener en cuenta que los valores indicados en el catálogo se refieren a carga está aplicada en una posición diferente, es necesario determinar la carga admisible en la posición deseada con las fórmulas correspondientes (ver el párrafo "Cargas Radiales" pág. 20-23).

TR

SERVİS FAKTÖRÜ

Servis faktörü (fb) redüktörün maruz kaldığı çalışma koşullarına göre değişkenlik gösterir.

En etkin servis faktörünü seçmek için göz önüne alınması gereken parametreler aşağıdaki hususlara bağlıdır:

- Çalışan makinadaki yükün tipi : **U - M - H**
- Günlük çalışma süresi : **saat / gün (Δ)**
- Start-Stop sıklığı : **başlangıç / saatler (*)**

YÜK TİPİ :	U - Uniform	$m_{af} \leq 0,3$
	M - Orta seviyeli şoklar	$m_{af} \leq 3$
	H - Ağır şoklar	$m_{af} \leq 10$

mfa = Je/Jm

- mfa Kuvvet hız faktörü
- Je (kgm²) sürüm şaftındaki indirgenmiş harici atalet momenti
- Jm (kgm²) motor atalet momenti

Eğer mfa değeri > 10 ise durumu Teknik Servisimize bildirin.

U- Hafif malzemeler için vida besleme aparatları, fanlar, montaj hatları hafif malzemeler naklinde kullanılan kemerler, küçük mikserler, lifter temizleme makineleri, dolgu makineleri, kontrol makineleri.

M- Helezonlar, ağaç işleme makineleri, besleme aparatları, malzeme lift makineleri, balans makineleri, pafta makineleri, orta boy mikserler, ağır malzeme naklinde kullanılan kemerler, vinçler, raylı kapılar, suni gübre spatulası, paketleme makineleri, beton mikserleri, vinç mekanizmaları, freze makineleri, bükme-kıvrırma makineleri, dişi pompalar.

H- Ağır malzemeler için mikserler, kırkma makası, presler, santrifüj makineleri, ayna destek aparatları, ağır malzemeler için lift ve vinçler, taşlama tezgahları, bileme taşları, pistonlu asansörler, matkap tezgahları, çekici milleri, mil dirsek presleri, bükme-kıvrırma makineleri, döner levhalar, silindir variller, vibratörler, kağıt öğütücüler.

EN

SERVICE FACTOR

The service factor (fb) depends on the operating conditions the reduction unit is subjected to. The parameters that need to be taken into consideration to select the most adequate service factor correctly comprise:

- Type of load of the operated machine: **U - M - H**
- Length of daily operating time: **hours/day**
- Start-up frequency: **starts/hour**

TYPE OF LOAD:	U - Uniform	$m_{af} \leq 0,3$
	M - Moderate shocks	$m_{af} \leq 3$
	H - Heavy shocks	$m_{af} \leq 10$

mfa = Je/Jm

- mfa factor of inertia
- Je (kgm²) moment of reduced external inertia at the drive-shaft
- Jm (kgm²) moment of inertia of motor

If mfa > 10 call our Technical Service.

U- Screw feeders for light materials, fans, assembly lines, conveyor belts for light materials, small mixers, lifts, cleaning machines, fillers, control machines.

M- Winding devices, woodworking machine feeders, goods lifts, balancers, threading machines, medium mixers, conveyor belts for heavy materials, winches, sliding doors, fertilizer scrapers, packing machines, concrete mixers, crane mechanisms, milling cutters, folding machines, gear pumps.

H- Mixers for heavy materials, shears, presses, centrifuges, rotating supports, winches and lifts for heavy materials, grinding lathes, stone mills, bucket elevators, drilling machines, hammer mills, cam presses, folding machines, turntables, tumbling barrels, vibrators, shredders.

DE

BETRIEBSFAKTOR

Der Betriebsfaktor (fb) hängt von den Betriebsbedingungen, ab, unter denen das Getriebe betrieben wird. Die Parameter, die für eine korrekte Auswahl des Betriebsfaktors zu berücksichtigen sind, sind folgende:

- Belastungsart der angetriebenen Maschine: **U - M - H**
- Tägliche Betriebsdauer: **Std./Tag**
- Anlaufhäufigkeit: **Anl./Std.**

LAST :	U - Gleichförmig	$m_{af} \leq 0,3$
	M - Mittlere Überlast	$m_{af} \leq 3$
	H - Hohe Überlast	$m_{af} \leq 10$

mfa = Je/Jm

- mfa Massenträgheitswert
- Je (kgm²) äußeres Trägheitsmoment reduziert auf die Motorwelle
- Jm (kgm²) Motor-Trägheitsmoment

Bei mfa > 10 bitte mit unserem Kundendienst Kontakt aufnehmen.

U- Schneckenförderer für Leichtmaterial, Gebläse, Montagebänder, Bandförderer für Leichtmaterial, kleine Rührwerke, Kleinlastenaufzüge, Kreiselpumpen, Hebebühnen, Reinigungsmaschinen, Abfüllmaschinen, Prüfmaschinen, Bandförderer.

M- Wickelmaschinen, Vorrichtungen zur Zuführung bei Holzbearbeitungsmaschinen, Lastaufzüge, Auswuchtmaschinen, Gewindeschneidmaschinen, mittlere Rührwerke und Mischer, Bandförderer für schwere Materialien, Winden, Schiebetore, Dünger Abkratzer, Verpackungsmaschinen, Betonmischmaschinen, Kranfahr- und Kranhubwerke, Fräsmaschinen, Biegemaschinen, Zahnpumpen, Hubstapler, Drehtische.

H- Rührwerke für schwere Materialien, Scheren, Pressen, Schleudern, Winden und Aufzüge für schwere Materialien, Schleifmaschinen, Steinbrecher, Kettenbecherwerke, Bohrmaschinen, Hammermühlen, Exzenterpressen, Biegemaschinen, Drehtische, Scheuertrommeln, Vibrationsrüttler, Schneidemaschinen, Stanzen, Walzwerke, Zementmühlen.

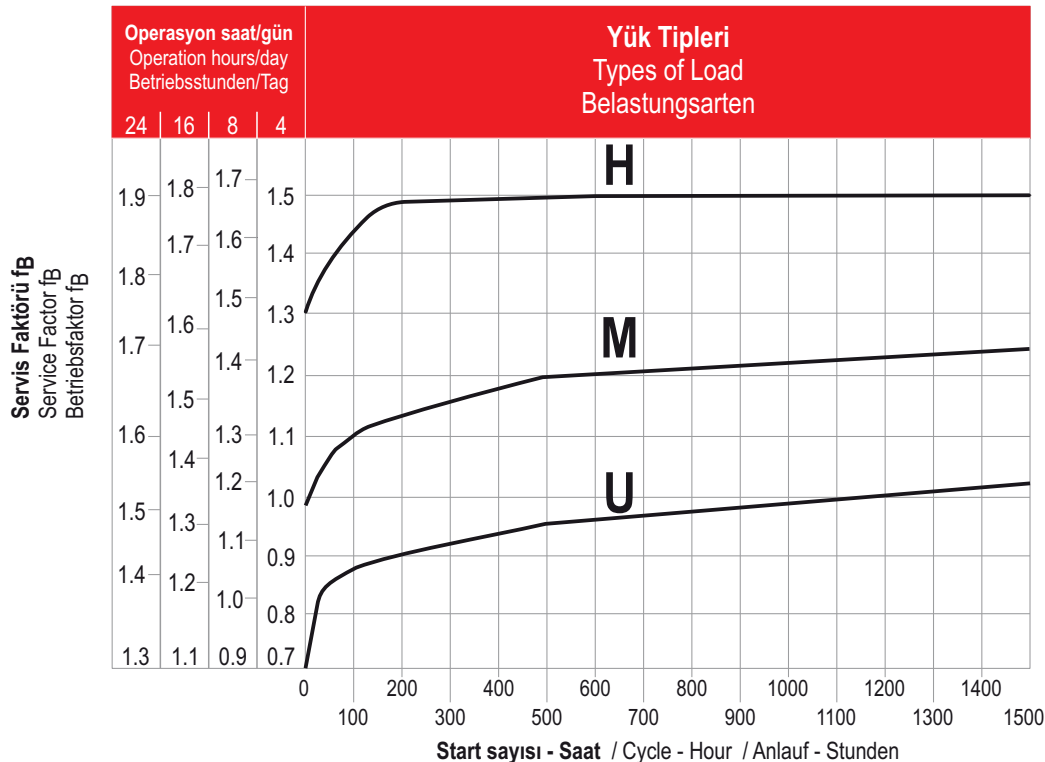

IT FATTORE DI SERVIZIO

Il fattore di servizio (fb) dipende dalle condizioni di funzionamento alle quali il riduttore è sottoposto.

I parametri che occorre considerare per una corretta selezione del fattore di servizio più adeguato sono:

- Tipo del carico della macchina azionata: **U - M - H**
- Durata di funzionamento giornaliero: **ore/giorno**
- Frequenza di avviamento: **avv/ora**

TIPO DEL CARICO:	U - Uniforme	$m_{af} \leq 0.3$
	M - Medio	$m_{af} \leq 3$
	H - Forte	$m_{af} \leq 10$

mfa = Je/Jm

- mfa fattore d'inerzia
 - Je (kgm²) momento d'inerzia esterno ridotto all'albero motore
 - Jm (kgm²) momento d'inerzia motore
- Se mfa > 10 interpellare il ns. Servizio Tecnico.

U- Coclee per materiali leggeri, ventole, linee di montaggio, nastri trasportatori per materiali leggeri, piccoli agitatori, elevatori, macchine pulitrici, macchine riempitrici, macchine per il controllo, nastri trasportatori.

M- Dispositivi di avvolgimento, apparecchi per l'alimentazione delle macchine per il legno, montacarichi, equilibratrici, filettatrici, agitatori medi e mescolatori, nastri trasportatori per materiali pesanti, verricelli, porte scorrevoli, raschiatore di concime, macchine per l'imballaggio, betoniere, meccanismi per il movimento delle gru, frese, piegatrici, pompe a ingranaggi.

H- Agitatori per materiali pesanti, cesoie, prese, centrifughe, supporti rotanti, verricelli ed ascensori per materiali pesanti, torni per la rettifica, frantoi da pietre, elevatori a tazze, perforatrici, mulini a meartello, presse as eccentrico, piegatrici, tavoli rotanti, barilatrici, vibratori, trinciatrici.

FR FACTEUR DE SERVICE

Le facteur de service (fb) est subordonné aux conditions de fonctionnement auxquelles le réducteur est soumis. Les paramètres qu'il faut considérer pour un choix correct du facteur de service adéquat sont les suivants:

- Type de charge de la machine actionnée: **U-M-H**
- Durée de fonctionnement journalière: **heures / jour**
- Fréquence de démarrage: **dém / heure**

TIPO DE CHARGE:	U - Uniforme	$m_{af} \leq 0.3$
	M - Surcharge moyenne	$m_{af} \leq 3$
	H - Surcharge forte	$m_{af} \leq 10$

mfa = Je/Jm

- mfa facteur d'inertie
 - Je (kgm²) moment d'inertie extérieur ramené à l'arbre-moteur
 - Jm (kgm²) moment d'inertie moteur
- En cas de mfa > 10, contacter notre S. ce Technique.

U- Vis d'Archimède pour matériaux légers, ventilateurs, lignes de montage, convoyeurs pour matériaux légers, petits agitateurs, élévateurs, machines à nettoyer, machines à remplir, machines pour le contrôle, convoyeurs.

M- Dispositifs d'enroulement, appareils pour l'alimentation des machines pour le bois, monte - charges, équilibreuses, taraudeuses, agitateurs moyens et mélangeurs, convoyeurs pour matériaux lourds, treuils, portes coulissantes, racleurs d'engrais, machines à emballer, plieuses, pompes à engrenages.

H- Agitateurs pour matériaux lourds, cisailles, presses, centrifugeuses, supports rotatifs, treuils et ascenseurs pour matériaux lourds, tours pour la rectification, concasseurs de pierres, élévateurs à godets, perceuses, moulins à marteaux, presses à excentrique, plieuses, tables tournantes, polisseuses, vibrateurs, machines à hacher.

ES FACTOR DE SERVICIO

El factor de servicio (fb) depende de las condiciones de funcionamiento a las cuales está sometido el reductor. Los parámetros que deben ser considerados para una correcta selección del factor de servicio más adecuado son:

- Tipo de carga de la máquina accionada: **U-M-H**
- Duración de funcionamiento diario: **horas/día**
- Frecuencia de arranques: **arr/hora**

TIPO DE CARGA:	U - Uniforme	$m_{af} \leq 0.3$
	M - Sobrecarga media	$m_{af} \leq 3$
	H - Sobrecarga fuerte	$m_{af} \leq 10$

mfa = Je/Jm

- mfa factor de inercia
 - Je (kgm²) inercia externa reducida al eje motor
 - Jm (kgm²) inercia motor
- En caso de mfa > 10, ponerse en contacto con nuestro Servicio Técnico.

U- Tornillos de Arquimedes para materiales ligeros, ventiladores, líneas de montaje, cintas transportadoras para materiales ligeros, pequeños agitadores, elevadores, máquinas limpiadoras, máquinas llenadoras, máquinas comprobadoras, cintas transportadoras.

M- Dispositivos de enrollado, alimentadores de las máquinas para la madera, montacargas, equilibradores, roscadoras, agitadores medios y mezcladores, cintas transportadoras para materiales pesados, cabrestantes, puertas corredizas, raspadores de abono, máquinas empaquetadoras, puertas corredizas, raspadores de abono, máquinas empaquetadoras, hormigoneras, mecanismos para el movimiento de las grúas, fresadoras, plegadoras, bombas de engranajes.

H- Agitadores para materiales pesados, cizallas, prensas, centrifugadoras, soportes rotativos, cabrestantes y elevadores para materiales pesados, tornos para la rectificación, molinos de piedras, elevadores de cangilones, perforadoras, molidores a percusión, prensas de excéntrica, plegadoras, mesas giratorias, pulidoras, vibradores, cortadoras.

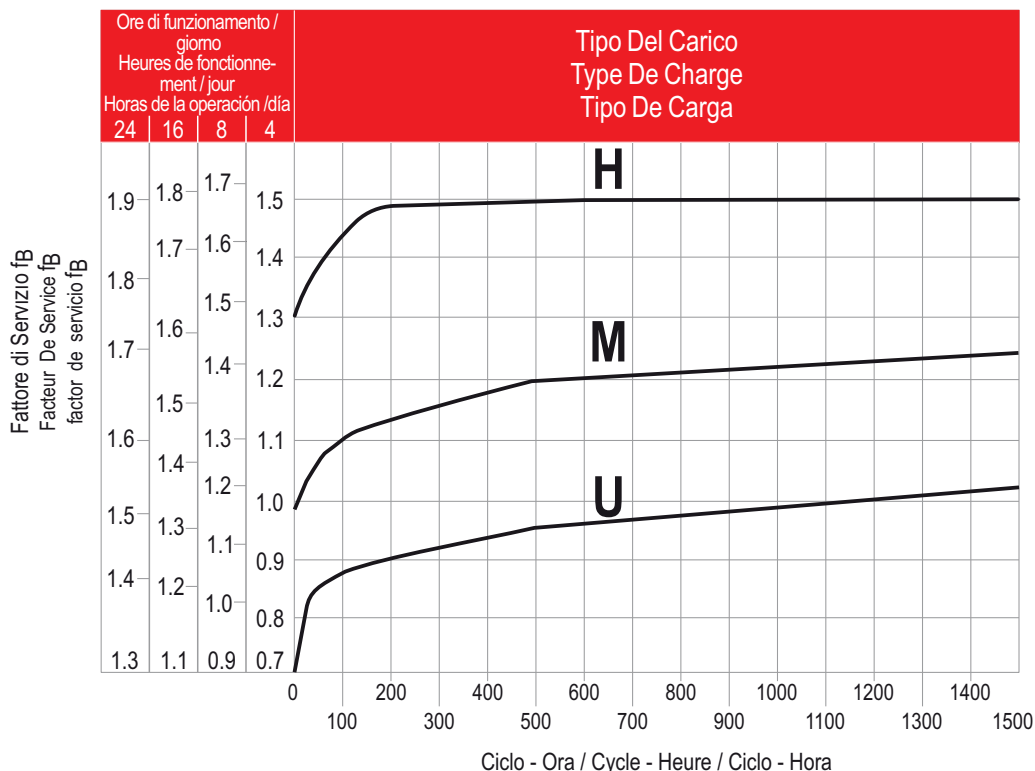

TR KRİTİK UYGULAMALAR

Katalogta verilen performans değerleri M1 montaj pozisyonu ve buna benzer durumlar içindir. Örneğin: İlk kademe komple yağ içinde olmadığı durumlar. Diğer montaj pozisyonu değişik giriş hızları ve her bir redüktör gövdesi için kritik uygulama durumları tabloda sunulmuştur. Aşağıdaki uygulamalar için de teknik servisimize danışılması gerekir.

- Yüksek ataletli uygulamalar.
- Redüktörde yüksek dinamik gerilmelere sebep olabilecek uygulamalar.
- -5°C altında veya 40°C üzerindeki iş ortamında yapılan uygulamalar.
- Katalogta belirtilmeyen montaj pozisyonlarında kullanım.
- Redüktör ünitesinin sorun yaşanmasında canlılara zarar verebileceği uygulamalar.
- Hız artışı durumunda.
- Kaldırma vinci olarak kullanım.
- Atmosferik basınçtan farklı basınç tiplerinin bulunduğu ortamlarda kullanım.
- Kimyasal aşındırıcı çevrelerde kullanım.
- Tuzlu ortamlarda kullanım.
- Radyoaktif ortamlarda kullanım.

Redüktörün bir kısmının batırılması gerektiği uygulama ortamlarından sakının.

Redüktörün dayanabileceği maksimum moment değeri (*) performans tablolarında belirtilen nominal moment değerinin ($f_b = 1$) iki katı bir değeri aşmamalıdır.

(*) Maksimum kapasiteli yük değerleri ile yapılan başlatmalarda, frenlemede, özellikle dinamik olan şok ve diğer nedenlerde, momente bağlı aşırı yüklerde geçerlidir.

EN CRITICAL APPLICATIONS

The performance given in the catalogue correspond to mounting position M1 or similar, ie. when the first stage is not entirely immersed in oil. For other mounting positions and/or particular input speeds, refer to the tables that highlight different critical situations for each size of reduction unit. It is also necessary to take due consideration of and carefully assess the following applications by calling our Technical Service:

- Applications with especially high inertia.
- Applications with high dynamic strain on the case of the reduction unit.
- In places with T° under -5°C or over 40°C
- Mounting positions not envisaged in the catalogue.
- Use in services that could be hazardous for people if the reduction unit fails..
- As a speed increasing.
- Use as a lifting winch.
- Use in environments pressures other than atmospheric pressure.
- Use in chemically aggressive environments.
- Use in a salty environment
- Use in radioactive environments.

Avoid applications where even partial immersion of the reduction unit is required.

The maximum torque (*) that the gear reducer can support must not exceed two times the nominal torque ($f_b = 1$) stated in the performance tables.

(*) intended for momentary overloads due to starting at full load, braking, shocks or other causes, particularly those that are dynamic.

DE KRITISCHE ANWENDUNGEN

Die im Katalog aufgeführten Leistungsdaten gelten für die Einbaulage M1 oder gleichwertig, wenn das Ritzel nicht völlig mit Öl geschmiert wird.

Für andere Einbaulagen und / oder besondere Antriebsdrehzahlen sind die Tabellen zu beachten, die verschiedene kritische Zustände für jede Getriebegröße darstellen. Darüber hinaus sind nachstehende Anwendungen zu beachten und eventuell sollte mit unserem Kundendienst Kontakt aufgenommen werden:

- Anwendungen mit sehr hohen Trägheitsmomenten.
- Anwendungen mit hohen dynamischen Beanspruchungen auf Getriebegehäuse.
- Einsatz bei Umgebungstemperaturen unter -5°C oder über 40°C.
- Nicht im Katalog vorgesehene Einbaulagen.
- Anwendungen, die bei Bruch des Getriebes für den Menschen gefährlich sein könnten.
- Einsatz als Übersetzungsgetriebe (Übersetzung ins Schnelle).
- Einsatz als Hebewinde.
- Einsatz unter einem Druck, der nicht dem normalen Luftdruck entspricht.
- Einsatz in Verbindung mit aggressiven chemischen Substanzen.
- Einsatz unter Salzwassereinwirkung.
- Einsatz unter radioaktiver Strahlung.

Anwendungen, bei denen das Eintauchen des Getriebes in Wasser vorgesehen ist (auch teilweise), sollen vermieden werden. Das max. zulässige Drehmoment (*) des Getriebes, darf nicht den zweifachen Wert des in der Leistungstabelle angegebenen nominalen Wert des Drehmomentes ($f_b = 1$) übersteigen.

(*) Hierbei sind Überlasten gemeint, welche durch Anlaufen unter Vollast, Bremsungen, Stöße und weiter dynamische Ursachen, hervorgerufen werden.

A/F	202	202 G	252 - 253	301-302-303	351-352-353	401-402-403	501-502-503	601-602-603	701-702-703	902-903
M4 : 1500 < n1 < 3000	P	P	-	-	-	-	-	-	P	P
n1 > 3000	X	X	P	P	P	P	P	P	X	X
M2	P	P	P	P	P	P	P	P	P	P

X Uygulama yapılması tavsiye edilmez
Application not recommended
Nicht empfohlene Anwendung

P Yapılan uygulamayı kontrol edin ve/veya Teknik Servisimize durumu bildirin.
Check the application and/or call our technical service.
Anwendung überprüfen und/oder mit unserem Kundendienst Kontakt aufnehmen.

IT **APPLICAZIONI CRITICHE**

Le prestazioni indicate a catalogo corrispondono alla posizione M1 o similari, quando cioè il primo stadio non è interamente immerso in olio. Per situazioni di piazzamento diverse e/o velocità di ingresso particolari attenersi alle tabelle che evidenziano situazioni critiche diverse per ciascuna taglia di riduttore. Occorre anche tenere nella giusta considerazione e valutare attentamente le seguenti applicazioni consultando il ns. Servizio Tecnico:

- Applicazioni con inerzie particolarmente elevate.
- Applicazioni con elevate sollecitazioni dinamiche sulla cassa del riduttore.
- Utilizzo in ambiente con T° inferiore a -5°C o superiore a 40°C
- Posizioni di piazzamento non previste a catalogo.
- Utilizzo in servizi che potrebbero risultare pericolosi per l'uomo in caso di rottura del riduttore.
- Utilizzo come moltiplicatore.
- Utilizzo come argano di sollevamento.
- Utilizzo in ambiente con pressione diversa da quella atmosferica.
- Utilizzo in ambiente con presenza di aggressivi chimici.
- Utilizzo in ambiente salmastro.
- Utilizzo in ambiente radioattivo.

Evitare applicazioni dove è prevista l'immersione, anche parziale, del riduttore. La coppia massima (*) sopportabile dal riduttore non deve superare il doppio della coppia nominale ($f_B = 1$) riportata nelle tabelle delle prestazioni. (*)intesa come sovraccarico istantaneo dovuto a avviamenti a pieno carico, frenature, urti ed altre cause soprattutto dinamiche.

FR **APPLICATIONS CRITIQUES**

Les performances indiquées sur le catalogue correspondent à la position M1 ou similaires, lorsque le premier train d'engrenage n'est pas entièrement immergé dans l'huile. Pour les combinaisons d'assemblage différentes et/ou les vitesses d'entrée particulières, se conformer aux tableaux qui mettent en évidence les différentes situations critiques pour chaque taille de réducteur. Il faut aussi prendre en considération et évaluer attentivement les applications suivantes, en consultant notre S.ce Technique:

- Applications avec inerties particulièrement élevées.
- Applications avec sollicitations dynamiques sur la carcasse du réducteur.
- Emploi en milieu avec température au - dessous de -5°C ou au-dessus de 40°C.
- Positions de montage non prévues sur le catalogue.
- Emploi en services qui pourraient être dangereux pour l'homme en cas de rupture du réducteur.
- Emploi comme multiplicateur.
- Emploi comme treuil, en cas de soulèvement.
- Emploi en milieu ayant une pression différente de celle atmosphérique.
- Emploi en milieu en présence d'agents chimiques agressifs.
- Emploi en milieu saumâtre.
- Emploi en milieu radioactif.

Eviter les applications dans lesquelles l'immersion du réducteur, même si partielle, est prévue. Le couple maximum (*) supporté par le réducteur ne doit pas être supérieur au double du couple nominal ($f_B = 1$) suivant notre table de prestation. (*) Entendu comme surcouple instantané dû à démarrages en pleine charge, freinages, chocs et autres causes surtout dynamiques.

ES **APLICACIONES CRITICAS**

Las prestaciones indicadas en el catálogo corresponden a la posición M1 o similares, cuando el primer tren de engranajes no está completamente inmerso en el aceite. Para posiciones de montaje distintas y/o de velocidades particulares a la entrada, atenderse a las tablas que ponen en evidencia las distintas situaciones críticas por cada tamaño de reductor. Además es necesario considerar y evaluar cuidadosamente las siguientes aplicaciones, poniéndose en contacto con nuestro Servicio técnico:

- Aplicaciones con inercias particularmente elevadas.
- Aplicaciones con esfuerzos dinámicos elevados sobre la carcasa del reductor.
- Utilización en ambiente con T° inferior a -5°C o superior a 40°C.
- Posiciones en montaje no previstas en el catálogo.
- Utilización en servicios que, en caso de ruptura del reductor, podrían resultar peligrosos para el hombre.
- Utilización como multiplicador.
- Utilización como cabrestante de levantamiento.
- Utilización en ambiente con presión distinta de la atmosférica.
- Utilización en ambiente con presencia de agentes químicos agresivos.
- Utilización en ambiente salino.
- Utilización en ambiente radioactivo.

Evitar aplicaciones donde es prevista la inmersión, aún parcial, del reductor. El par máximo (*) soportable por el reductor no debe superar el doble del par nominal ($f_B = 1$) indicado en la tabla de prestaciones. (*) Entendida como sobrecarga instantánea debida a puestas en marcha a plena carga, frenados, impactos y otras causas sobretodo dinamicas.B

A/F	202	202 G	252 - 253	301-302-303	351-352-353	401-402-403	501-502-503	601-602-603	701-702-703	902-903
M4 : 1500 < n1 < 3000	P	P	-	-	-	-	-	-	P	P
n1 > 3000	X	X	P	P	P	P	P	P	X	X
M2	P	P	P	P	P	P	P	P	P	P

X Applicazione sconsigliata
Application non conseillée
Aplicación desaconsejada

P Verificare l'applicazione e/o contattare il ns. servizio tecnico.
Verifier l'application et/ou contacter notre s.ce technique.
Controlar la aplicación y/o ponerse en contacto con nuestro servicio técnico.

TR TERMAL GÜÇ Pt [kW]

Tabloda referans verilen koşullara göre termal güç kW olarak belirtilmiştir.

- Montaj pozisyonu M1
- Sürekli çalışma ≤ 1500 rpm
- Çevre sıcaklığı: 25°C
- Deniz seviyesinin üzerindeki yükseklik
- Redüktör üzerindeki rüzgar hızı ≥ 1 m/s
- Radyal ve/veya aksel kuvvet olmadan

EN THERMAL POWER Pt [kW]

The table below list the nominal thermal power values expressed in kW, in the following reference conditions:

- Mounting position M1
- Continuous operation at input speed ≤ 1500 rpm
- Ambient temperature 25°C
- Sea level altitude
- Air speed near the gear reducer ≥ 1 m/s
- Absence of external radial and/or axial loads

DE THERMISCHE LEISTUNG Pt [kW]

Die folgende Tabelle enthält die Werte der thermischen Nennleistung in kW unter den folgenden Referenzbedingungen:

- Montageposition M1
- Dauerbetrieb mit Eingangsgeschwindigkeit ≤ 1500 rpm
- Umgebungstemperatur von 25°C
- Höhe über dem Meeresspiegel
- Geschwindigkeit der Luft im Getriebeinneren ≥ 1 m/s
- Abwesenheit von radialen und/oder axialen externen Belastungen

1500 rpm Termal güç / Thermal power values at 1500 rpm / Thermische Leistungen bei 1500 rpm	
Redüktör / Gear reducer / Getriebe	Pt [kW]
202	-
202 G	-
252 - 253	5.0
301	6.0
302 - 303	7.0
351	8.5
352 - 353	9.0
401	13.5
402 - 403	15.5
502 - 503	24.0
501	27.2
602 - 603	30.0
601	51.5
702 - 703	36.0
701	67.5
902 - 903	49.0

Redüktöre uygulanan Pt değerlerin üzerine çıkmaz ise yeterli yağlama ile redüktörün düzenli çalışması garanti edilir.

Applying a power level not exceeding Pt at the above mentioned reference conditions guarantees the correct lubrication and efficient operation of the gear reducer.

Durch die Anwendung einer die Pt nicht übersteigenden Leistung an das Getriebe wird eine ausreichende Schmierung und eine gute Funktionsweise des Getriebes gewährleistet.

Kullanımın kontrolü

Sürekli çalıştırma dışında, yani 2 saat altında çalıştırma durumunda ve ardından gelen dinlendirme, böylece redüktör çevre sıcaklığı ile soğuması, her bir uygulama için redüktörün termal sınırını aşağıdaki formül ile kontrol etmenizi tavsiye ederiz.

Application check

Except for continuous operating times below two (2) hours and successive pauses capable of bringing the gear reducer back to ambient temperature, for each application it is advisable to verify the gear reducer's thermal limit according to the following formula:

Prüfung der Anwendung

Mit Ausnahme von durchgängigen Betriebszeiten unter zwei (2) Stunden und anschließenden Pausen, bei denen das Getriebe auf die Umgebungstemperatur abkühlt, ist es ratsam bei jeder Anwendung die thermische Grenze des Getriebes mit der folgenden Formel zu überprüfen:

$$P1 < Pt * Fc * Fv * Fa$$

$$P1 < Pt * Fc * Fv * Fa$$

$$P1 < Pt * Fc * Fv * Fa$$

P1= Redüktörün giriş gücü 1400 d/d (4 kutuplu Motor)

Pt = Referans verilen termal güç (yukarıdaki tabloya bakınız)

Fc= Çevre sıcaklığı ve kullanım düzeltme faktörü

Fv= Fan düzeltme faktörü

Fa= Rakım düzeltme faktörü (Sıfır seviyesi).

where:

P1= input power to the gear reducer at 1.400 rpm (4-pole motors)

Pt = thermal power at reference conditions (see above table)

Fc = ambient and operating temperature correction factor

Fv = ventilation correction factor

Fa = altitude correction factor

dabei ist :

P1 = Eingangleistung des Getriebes 1400 rpm (Motor mit 4 Polen)

Pt = Thermische Leistung unter Referenzbedingungen (siehe Tabelle oben)

Fc = Korrekturfaktor für Umgebungstemperatur und Betrieb

Fv = Korrekturfaktor für Belüftung

Fa = Korrekturfaktor für Höhe über NN

Düzelme faktörleri çalışma şartlarına göre, ancak referans verilen şartlara göre değişiklik gösteren değerler ISO14179 tabloda gösterilir.

The correction factors refer to different operating conditions compared to the reference conditions, and are provided by following ISO 14179 tables:

Die Korrekturfaktoren beziehen sich auf Betriebsbedingungen, die von den Referenzbedingungen abweichen und werden in den folgenden ISO14179-Tabellen aufgeführt:

IT POTENZA TERMICA Pt [kW]

La seguente tabella riporta i valori di potenza termica nominale espressa in kW nelle seguenti condizioni di riferimento:

- Posizione di montaggio M1
- Funzionamento continuo con velocità di entrata ≤1500 rpm
- Temperatura ambiente di 25°C
- Altitudine pari al livello del mare
- Velocità dell'intorno del riduttore ≥1m/s
- Assenza di carichi radiali e/o assiali esterni

FR PUISSANCE THERMIQUE Pt [kW]

Le tableau suivant présente les valeurs de puissance thermique nominale exprimées en kW dans les conditions de référence suivantes:

- position de montage M1
- fonctionnement continu avec vitesse d'entrée ≤ 1500 rpm
- température ambiante de 25°C
- altitude égale au niveau de la mer
- vitesse de l'air à proximité du réducteur ≥ 1m/s
- absence de charges radiales et/ou axiales externes

ES POTENCIA TÉRMICA Pt [kW]

La siguiente tabla contiene los valores de potencia térmica nominal expresada en kW en las siguientes condiciones de referencia:

- posición de montaje M1
- funcionamiento continuo con velocidad de entrada ≤1500 rpm
- temperatura ambiente de 25°C
- altura sobre el nivel del mar
- velocidad del aire en torno al reductor ≥1m/s
- ausencia de cargas radiales y/o axiales externas

Potenza termiche a 1500 rpm / Puissances thermiques à 1500 rpm / Potencias térmicas a 1500 rpm	
Riduttore / Réducteur / Reductor	Pt [kW]
202	-
202 G	-
252 - 253	5.0
301	6.0
302 - 303	7.0
351	8.5
352 - 353	9.0
401	13.5
402 - 403	15.5
502 - 503	24.0
501	27.2
602 - 603	30.0
601	51.5
702 - 703	36.0
701	67.5
902 - 903	49.0

Applicando al riduttore, nelle suddette condizioni di riferimento una potenza non superiore a Pt, risultano garantiti una corretta lubrificazione ed il buon funzionamento del riduttore.

Verifica della applicazione

Fatta eccezione per tempi di funzionamento continuo inferiori a due (2) ore e successive pause ingrandi di riportare il riduttore a temperatura ambiente, per ogni applicazione è consigliabile eseguire la verifica del limite termico del riduttore, secondo la seguente formula:

$$P1 < Pt * Fc * Fv * Fa$$

dove:

P1 = potenza in ingresso al riduttore a 1400 rpm (motori a 4 poli)

Pt = potenza termica in condizioni di riferimento (vedi tabella sopra)

Fc = fattore correttivo di temperatura ambiente e servizio

Fv = fattore correttivo di aerazione

Fa = fattore correttivo dell'altitudine

I fattori correttivi sono relativi a condizioni operative differenti da quelle di riferimento, e sono forniti dalle seguenti tabelle ISO14179:

L'application au réducteur d'une puissance inférieure à la Pt, dans les conditions de référence indiquées ci-dessus, garantit une lubrification correcte et le bon fonctionnement du réducteur.

Vérification de l'application

À l'exception de périodes de fonctionnement continu inférieures à deux (2) heures et de pauses successives permettant au réducteur de redescendre à une température ambiante pour toute application, il est conseillé d'effectuer une vérification de la limite thermique du réducteur, selon la formule suivante

$$P1 < Pt * Fc * Fv * Fa$$

où:

P1 = puissance d'entrée au réducteur à 1400tr/min (moteurs à 4 o-pôles)

Pt = puissance thermique dans les conditions de référence (voir tableau ci-dessus)

Fc = facteur de correction de température ambiante et de service

Fv = facteur de correction d'aération

Fa = facteur de correction de l'altitude

Les facteurs de correction correspondent à des conditions de fonctionnement différentes de celles de référence, et sont fournis par les tableaux ISO14179 suivants:

En las condiciones de referencia mencionadas, aplicando al reductor una potencia no mayor que la Pt, se garantiza una correcta lubricación y el buen funcionamiento del reductor.

Controlar la aplicación

Salvo cuando los tiempos de funcionamiento continuo son menores que dos (2) horas y se producen pausas capaces de llevar el reductor a la temperatura ambiente, para cada aplicación es aconsejable realizar la verificación del límite térmico del reductor, según la siguiente fórmula:

$$P1 < Pt * Fc * Fv * Fa$$

donde:

P1 = potencia a la entrada del reductor a 1400rpm (motores de 4 polos)

Pt = potencia térmica en condiciones de referencia (ver la tabla de arriba)

Fc = factor de corrección de la temperatura ambiente y servicio

Fv = factor de corrección de aireación

Fa = factor de corrección de la altitud

Los factores de corrección son relativos a condiciones operativas diferentes a las de referencia y se encuentran en las siguientes tablas ISO14179:

TR TERMAL GÜÇ Pt [kW]

EN THERMAL POWER Pt [kW]

DE THERMISCHE LEISTUNG Pt [kW]

Fc		Çalışma saati % olarak saatte / Duty per hour of operation % / Betriebszeit in % pro Stunde				
		100	80	70	40	20
Ortam sıcaklığı Ambient temperature	10°C	1.15	1.21	1.32	1.55	2.07
	18°C	1.07	1.12	1.23	1.44	1.93
	25°C	1.00	1.05	1.15	1.35	1.80
Umgebungstemperatur	30°C	0.93	0.98	1.07	1.26	1.67
	40°C	0.83	0.87	0.95	1.12	1.49
	43°C	0.75	0.79	0.86	1.01	1.35
	50°C	0.67	0.70	0.77	0.90	1.21

Havalandırma düzeltme faktörü / Geschwindigkeit der Umgebungsluft / Ventilation correction factor	Fv
Durgun hava (<0,5 m/s) / Stagnant air (<0,5 m/s) / Stehende Luft (<0,5 m/s)	0.75
Kapalı alandaki kurulum düşük hava sirkülasyonu / Indoor installation with slight ventilation / Installation in geschlossenen Räumen mit geringer Luftzirkulation	1
Kapalı alandaki kurulum iyi hava sirkülasyonu (>1,4 m/s) / Indoor Installation with good ventilation (>1,4 m/s) / Installation in geschlossenen Räumen mit guter Luftzirkulation (>1,4 m/s)	1.4
Serbest alanda kurulum (>3,7 m/s) / Outdoor installation (>3,7 m/s) / Installation im Freien (>3,7 m/s)	1.9

Rakım düzeltme faktörü / Altitude correction factor / Höhe über NN	Fa
0*	1
750	0.95
1500	0.90
2250	0.85
3000	0.81

* Deniz seviyesi

* Sea level

* Meeresniveau

Giriş devrinin 2000 d/d olması durumunda veya çevre sıcaklığının 40°C'nin üstünde olduğu durumlarda teknik departmanımıza danışmanızı tavsiye ederiz.

In caso of operation at input speeds exceeding 2000 rpm, or ambient temperatures greater than 40°C it is advisable to contact out technical department.

Im Fall eines Betriebs mit Eingangsgeschwindigkeiten über 2000 rpm oder bei Umgebungstemperaturen über 40°C wird empfohlen, den Kundendienst zu kontaktieren.

IT POTENZA TERMICA Pt [kW]

FR PUISSANCE THERMIQUE Pt [kW]

ES POTENCIA TÉRMICA Pt [kW]

Fc		Servizio a carico ora di funzionamento % / Facteur de marche par heure de fonctionnement % / Servicio con carga por hora de funcionamiento %				
		100	80	70	40	20
Temperatura ambiente	10°C	1.15	1.21	1.32	1.55	2.07
	18°C	1.07	1.12	1.23	1.44	1.93
	25°C	1.00	1.05	1.15	1.35	1.80
Température ambiente	30°C	0.93	0.98	1.07	1.26	1.67
	40°C	0.83	0.87	0.95	1.12	1.49
Temperatura ambiente	43°C	0.75	0.79	0.86	1.01	1.35
	50°C	0.67	0.70	0.77	0.90	1.21

Velocità dell'aria ambientale / Vitesse de l'air ambiant / Velocidad del aire ambiental	Fv
Aria stagnante (<0,5 m/s) / Air stagnant (<0,5 m/s) / Aire estancado (<0,5 m/s)	0.75
Installazione al chiuso con lieve aerazione / Installation en intérieur avec une légère aération / Instalación cubierta con poca aireación	1
Installazione al chiuso con aerazione (>1,4 m/s) / Installation en intérieur avec une aération correcte (>1,4 m/s) / Instalación cubierta con buena aireación (>1,4 m/s)	1.4
Installazione all'aperto (>3,7 m/s) / Installation en extérieur (>3,7 m/s) / Instalación al aire libre (>3,7 m/s)	1.9

Altitudine / Altitude / Altitud	Fa
0*	1
750	0.95
1500	0.90
2250	0.85
3000	0.81

* Livello del mare

* Niveau de la mer

* Nivel del mar

In caso di funzionamento con velocità di ingresso maggiori di 2000 rpm, o temperature ambiente maggiori di 40°C è consigliabile contattare il ns servizio di assistenza.

En cas de fonctionnement avec des vitesses d'entrée supérieures à 2000 tr/min ou en présence de températures ambiantes supérieures à 40°C, il est conseillé de contacter notre service d'assistance.

En el caso de funcionamiento con velocidades de entrada mayores que 2000 rpm o temperaturas ambiente mayores que 40°C es aconsejable llamar a nuestro servicio de asistencia técnica.

TR PAM B5 FLANŞI İLE MOTOR MONTAJI

Redüktör motorsuz olarak tedarik edildiğinde elektrik motorunun doğru olarak monte edildiğinden emin olmak için aşağıdaki tavsiyelere uyulmak zorundadır.

Motor şaftı ve flanş toleranslarının standartla uygun olup olmadığını kontrol edin. Dikkatlice şaftı, tapayı ve flanş yüzeylerini, boyadan arta kalan parçacıkları ve tozları temizleyip, kamanın doğru olarak yerleştirilip yerleştirilmediğini kontrol edin. Flanş montajlı motorun Pam flanşlı redüktöre montajında kaplin kullanılır.

Gerekli montaj ekipmanı kullanıp motor milinin ve rulmanları zedelenmesinin önlenmesi sağlanarak motor miline kaplin montajı edilir.

Kaplinin elastik elemanı motor milinde bulunan yarım kapline yerleştirilir ve motor dikey pozisyonda yarım kaplinli sürücü çevirilerek kaplin elemanı hizalanır. Kama kanalları toleransla montajlanmalıdır.

EN MOTOR MOUNTING WITH PAM-IEC FLANGE B5

When the unit is supplied without motor, it is necessary to follow these recommendation to ensure the correct assembly of the electric motor.

Check that the tolerances for the motor shaft and flange correspond to the standard.

Carefully clean the shaft, spigot and surfaces of the flange removing traces of paint and dirt, and confirm the key is fitted correctly.

Fit the half coupling to the motor shaft (see picture) taking care to ensure the motor shaft and bearings are not damaged by avoiding excessive force and where necessary using assembly equipment.

Place the couplings elastic element on to the motor half coupling and position the motor up to the gear unit ensuring the coupling element is aligned with the driven half coupling.

Complete the assembly using the fixing bolts. Key-ways with tightened tolerances.

DE MONTAGE DES MOTORS AN DEN PAM-IEC FLANSCH B5

Bei Getrieben, welche ohne Motor geliefert werden, sind folgende Vorsichtsmaßnahmen zu beachten, um eine korrekte Montage des Elektromotors zu gewährleisten.

Übereinstimmung der Toleranzen von Welle und Motorflansch überprüfen.

Diese sollten mindestens DIN 42955 N entsprechen. Welle, Passung und Flanschfläche sind sorgfältig von Schmutz, Spänen oder Lackresten zu säubern.

Halbkupplung auf Motor (siehe Bild) einsetzen, andernfalls sind die korrekte Ausrichtung und die Toleranz der Paßfeder zu überprüfen. In jedem Fall sind solche Montageverfahren anzuwenden, die Schäden an den Motorlagern ausschließen.

Motor anbauen, wobei zuerst darauf geachtet werden muss, dass die Halbkupplung auf dem Motor und der elastische Zwischenring auf der Getriebehalbkupplung frei eingreifen können.

Keine Anpassung der Motorpaßfeder ist in diesem Fall erforderlich.

IT MONTAGGIO MOTORE SU FLANGE PAM-IEC B5

Quando il gruppo viene fornito senza motore occorre osservare le seguenti raccomandazioni per garantire un corretto montaggio del motore elettrico.

Controllare che le tolleranze dell'albero e della flangia motore siano corrispondenti almeno a una classe di qualità "normale".

Pulire accuratamente l'albero, il centraggio ed il piano della flangia da sporco o tracce di vernice.

Procedere al montaggio del semigiunto (vedi figura) sull'albero del motore elettrico che deve avvenire senza eccessiva forzatura, in caso diverso controllare la coretta posizione e la tolleranza della linguetta motore;

Procedere quindi al montaggio del motore completo di semigiunto facendo i denti di trascinamento del semigiunto lato motore con quelli dell'elemento elastico presente sul semigiunto fisso lato riduttore.

Non è previsto nessun adattamento della linguetta motore.

FR INSTALLATION MOTEUR SUR BRIDE PAM-IEC B5

Quand le groupe est fourni sans moteur, observez les recommandations suivantes pour garantir un montage correct du moteur électrique.

Contrôler que les tolérances de l'arbre et de la bride du moteur correspondent au moins à une classe de qualité "normale".

Nettoyer soigneusement l'arbre, le centrage et le plan de la bride des traces de saleté et de peinture.

Procéder au montage de demi - accouplement sur l'arbre moteur électrique sans forcer (voir image), dans le cas contraire, vérifier la position correcte et la tolérance de la clavette du moteur.

Utiliser, toutefois, des systèmes appropriés qui garantissent un montage correct sans risquer de détériorer les roulements du moteur. Procéder de la même façon pour le montage du moteur avec le demiaccouplement coté moteur avec de l'élément élastique du demiaccouplement coté réducteur.

Rainures clavette moteur avec tolérances réduites.

ES MONTAJE DE MOTORES CON BRIDA B5

Sie al equipo se suministra sin motor es preciso observar las siguientes recomendaciones ara garantizar un correcto montaje del motor eléctrico.

Verificar que la tolerancia del eje y de la brida motor se correspondan al menos a una clase de calidad "normal".

Limpiar uidadosamente el eje, el centrage y el plano de asiento de restos de barniz o suciedad.

Proceder al montaje del semiacoplamiento en el eje del motor eléctrico sin excesiva fuerza, si no entra con suavidad verificar la correcta tolerancia de la chaveta del motor (ver imagen), utilizar en cualquier caso métodos de montaje que no dañen los rodamientos del motor.

Proceder a continuación al montaje del motor con el semiacoplamiento en el reductor, evitando la interferencia de los dientes del acoplamiento.

No se prevé ninguna adaptación de la chaveta del motor.

IEC BAĞLANTILI / IEC SLEEVE / IEC BUCHSE / MANICOTTO IEC / MANCHON IEC / MANGUÏTO IEC

A - F IEC

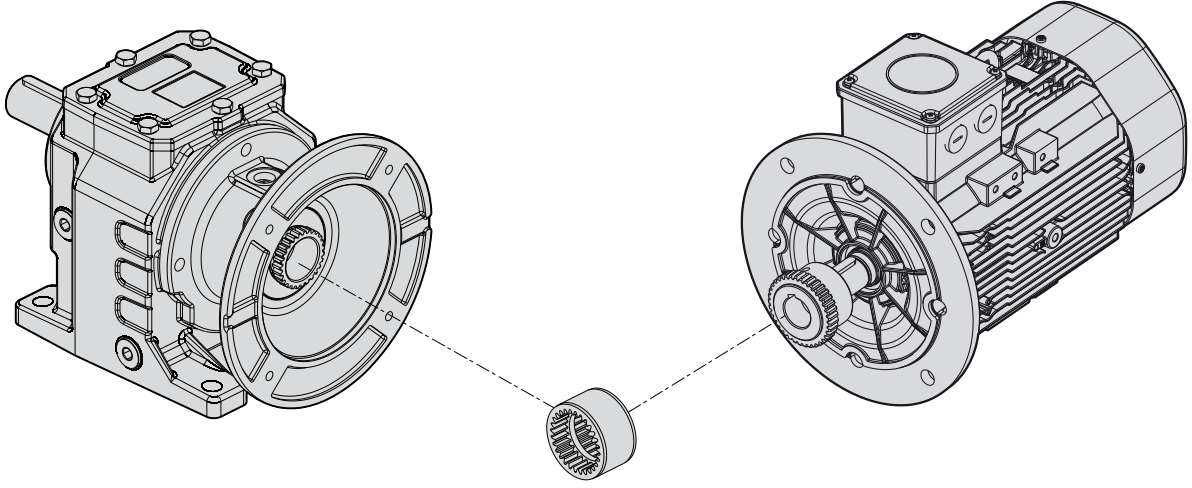

PAM BAĞLANTILI / PAM SLEEVE / PAM BUCHSE / MANICOTTO PAM / MANCHON PAM / MANGUÏTO PAM

A - F PAM

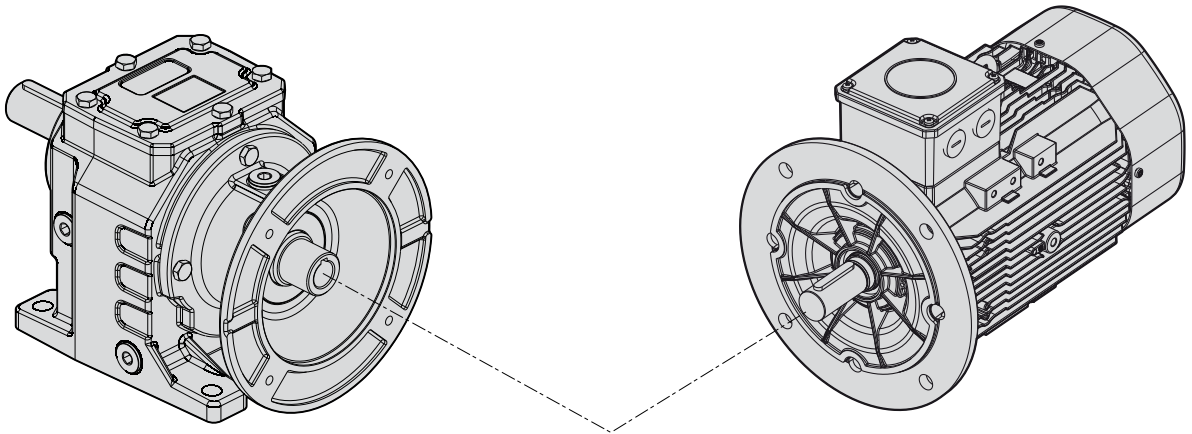

TR

MONTAJ

Redüktör ünitelerinden en uzun ve en verimli servis ömrü sağlamak için, uygulanacak makinaların üzerlerine doğru montaj yapılması gerekmektedir. Redüktörü monte etmek için aşağıdaki verilen tavsiyeleri uygulamanız gerekmektedir.

- Dışarıda yapılacak olan montajlarda, redüktör ünitesini kötü hava koşullarından koruyunuz. Korozyon önleyici madde kullanınız. Keçeleri su geçirmez gresle koruyunuz.
- Redüktör ünitesini sabitlemek için, seçim sayfalarındaki teknik çizimlerde belirtilen uygun civata ve somun kullanınız. Flanşlar üzerindeki bağlama deliklerinin hepsini kullandığınızdan emin olunuz.
- Redüktör üniteleri genellikle elektrik motorlarına flanşla direk bağlanır. Özellikle montajdan sonra hasara neden olabilecek kritik uygulamalarda bu durum söz konusudur.
- Yapılacak olan montaj işleminde makinada olabilecek bir titreşimi engellemek için sabit olmalıdır.
- Cihazı makineye monte etmeden önce redüktör çıkış şaftının dönme yönünün doğru olup olmadığını kontrol edin.
- Belirgin düzeyde uzun süreli olarak yapılacak depolama işlemlerinde (4/6 ay) şayet yağ keçesi cihaz içindeki yağa batık konumda değilse kauçuk parçanın şafta yapışma riski bulunduğundan veya doğru olarak çalışmasını engelleyebilecek şekilde elastikliğini kaybetme riski bulunduğundan parçanın değiştirilmesini tavsiye ederiz.
- Fan kısmından iyi bir hava akışı sağlanarak motor soğutmasının uygun bir şekilde yapıldığından emin olun. < -5°C veya >+40°C gibi aşırı ısı değerlerinin bulunduğu ortamda Teknik Servise başvurunuz.
- Değişik parçalar (makaralar, şanzuman, kaplin, şaft vb.) özel olarak açılmış delikler kullanılarak rulman yatağı veya harici parçalarına zarar vermeyecek şekilde tasarlanmış sistemler kullanmak suretiyle hasar riski olmadan mil yada delik milli üzerine monte edilmelidir. Birbirleriyle temas eden yüzeyleri aşınma veya paslanma riskine karşı yağlayınız.
- Yapılacak boyama işlemi kesinlikle keçe (kauçuk) parçaların alt kısımlarına nüfuz edecek şekilde veya varsa havalandırma deliklerini kapatacak şekilde olmamalıdır.
- Yağ tapası gönderilen redüktörlerin sevkiyatı için kullanılan kör tapa özel havalandırma tapası ile değiştirilir.
- Mümkünse yağ seviyesini indikatörle kontrol ediniz. Başlatma işi kademeli olarak maksimum güç yüklemesine hemen geçilmeden yapılmalıdır.
- Sınırlı düzeyde bile olsa yağ sızıntısı ile hasara uğrayabilecek motor altında parçalar, nesnelere veya malzemeler olması halinde bu durum için özel koruma yöntemleri geliştirilmelidir.

EN

INSTALLATION

For the longest and most efficient service life, drives must be correctly mounted on the application structure. Therefore, all structure faces must be machined with H8 spigots so that they are flat and perpendicular to the drive axis. To install the reduction unit it is necessary to note the following Recommendations:

- For outdoor installations, drives must be protected against bad weather, treated with anticorrosive agents and oil seals protected with water-repellent grease.
- To secure the drive, use the nuts and bolts shown under each technical drawing on the product technical sheets. Make sure to use all the fixing holes on the flanges.
- Drives are usually connected directly to what are mainly electric or hydraulic motors by means of flanges when there are particularly critical conditions that might cause damage after installation.
- The mounting on the machine must be stable to avoid any vibration.
- Before installing gearbox to your machine, please check rotation direction of output shaft is correct or not.
- Check the correct direction of rotation of the storage (4/6 months), if the oil seal is not immersed in the lubricant inside the unit, it is recommended to change it since the rubber could stick to the shaft or may even have lost the elasticity it needs to function properly.
- Ensure the motor cools correctly by assuring good passage of air from the fan side. In the case of ambient temperatures <-5°C or >+40°C call the Technical Service.
- The various parts (pulleys, gear wheels, couplings, shafts, etc.) must be mounted on the solid or hollow shafts using special threaded holes or other systems that anyhow ensure correct operation without risking damage to the bearings or external parts of the units. Lubricate the surfaces in contact to avoid seizure or oxidation.
- Painting must definitely not go over rubber parts and the holes on the breather plugs, if any.
- For units equipped with oil plugs, replace the closed plug used for shipping with the special breather plug.
- Check the correct level of the lubricant through the indicator, if there is one. Starting must take place gradually, without immediately applying the maximum load.
- When there are parts, objects or materials under the motor drive that can be damaged by even limited spillage of oil, special protection should be fitted.

DE

MONTAGE

Der korrekte Einbau des Getriebes in die entsprechende Vorrichtung der Applikation ist Voraussetzung, um einen einwandfreien und dauerhaften Betrieb zu gewährleisten. Vorallem die Oberflächen der Zentrierungen/Aufnahme sind in einer Toleranz H8 zu fertigen, damit die einwandfreie Uebereinstimmung mit der Getriebeachse garantiert wird. Für die Montage des Getriebes sind nachstehende Anweisungen zu beachten:

- Für im Freien betriebene Maschinen wird empfohlen, das Getriebe soweit wie möglich vor Witterungseinflüssen zu schützen sowie mit Rostschutzmittel zu behandeln. Die Dichtringe sind mit wasserabweisendem Fett zu versehen.
- Für die Befestigung sind die Schrauben zu verwenden, die in der Zeichnung / Teileliste des Modells vorgesehen sind. Dazu sind alle vorgesehenen Befestigungsbohrungen zu verwenden
- Der Anbau des Getriebes an Elektro oder Hydraulikmotor erfolgt normalerweise direkt über Flansche; vor allem, wenn eine außergewöhnliche Situation vorliegt, die nach erfolgtem Einbau Schäden verursachen könnte.
- Die Befestigung an der Maschine muss absolut stabil sein, um jegliche Vibrationen zu vermeiden.
- Vor der Montage des Getriebes an die Maschine ist die Abtriebswelle des Getriebes auf die richtige Drehrichtung zu prüfen.
- Nach besonders langer Einlagerung (4/6 Monate) ist zu überprüfen, ob die Wellendichtringe vom Schmiermittel des Getriebes vollständig benetzt wurden; Andernfalls ist ein Austausch anzuraten, da die Dichtlippe auf der Welle festkleben kann oder die zum einwandfreien Betrieb notwendige Elastizität nicht mehr vorhanden ist.
- Die Motorkühlung muss durch eine gute Belüftung durch den Lüfter gewährleistet werden. Bei Umgebungstemperaturen < -5°C oder > +40°C setzen Sie sich bitte mit dem Kundendienst in Verbindung.
- Zur Montage der unterschiedlichen Anbauteile (Riemenscheiben, Zahnräder, Kupplungen, Wellen usw.) auf den Hohl- oder Vollwellen sind die vorgesehenen Gewindebohrungen oder Aufziehvorrichtungen zu verwenden.
- Diese gewährleisten eine einwandfreie Montage, ohne die Lager oder die Außenteile des Getriebes zu beschädigen. Die in Berührung kommenden Passungen und Oberflächen der Wellen sind zu fetten/ölen, um ein Festfressen durch Passungsrost zu vermeiden.
- Bei Lackierung ist darauf zu achten, dass alle Gummiteile und fallweise die in den Entlüftungsdeckeln vorhandenen Bohrungen nicht überlackiert werden.
- Bei Getrieben mit Ölstopfen ist die zum Transport verwendete Verschlusschraube durch die beigelegte Entlüftungsschraube zu ersetzen.
- Der Schmierölstand ist an der Füllstandanzeige zu überprüfen, sofern vorhanden. Der Antrieb ist stufenweise in Betrieb zu nehmen, wobei zunächst mit Teillast angefahren werden sollte.
- Sind unter dem Antrieb Geräteteile oder Materialien angeordnet, die durch geringe Mengen austretenden Öls beschädigt werden könnten, so ist eine geeignete Schutzvorrichtung vorzusehen.

IT

INSTALLAZIONE

Per garantire un buon funzionamento dei riduttori ed una miglior durata nel tempo è necessario un corretto accoppiamento alla struttura cui viene fissato il gruppo. Pertanto le superfici di tale struttura dovranno essere lavorate con centraggi in H8 ed in modo da garantire un'ottima planarità e perpendicolarità con l'asse del riduttore. Per l'installazione del riduttore è consigliabile attenersi alle seguenti indicazioni:

- Per gruppi installati all'aperto si consiglia dove possibile, di proteggere i riduttori dalle intemperie, di trattarli con sistemi anticorrosivi e di proteggere i paraoli con grasso idrorepellente.
- Per il fissaggio del riduttore usare la bulloneria indicata sotto ogni disegno nelle schede tecniche di prodotto. Usare inoltre tutti i fori di fissaggio previsti sulle flange dei riduttori.
- L'abbinamento fra riduttori e motori, principalmente elettrici o idraulici, viene normalmente fatto mediante flangiatura diretta quando non si presentano particolari condizioni di criticità, che possono provocare danni dopo l'installazione.
- Il fissaggio sulla macchina deve essere stabile per evitare qualsiasi vibrazione.
- Verificare il corretto senso di rotazione dell'albero di uscita del riduttore prima del montaggio del gruppo sulla macchina.
- In caso di periodi particolarmente lunghi di stoccaggio (4/6 mesi) se l'anello di tenuta non è immerso nel lubrificante contenuto all'interno del gruppo si consiglia la sua sostituzione in quanto la gomma potrebbe essersi incollata all'albero o addirittura aver perso quelle caratteristiche di elasticità necessarie al corretto funzionamento.
- Garantire un corretto raffreddamento del motore assicurando un buon passaggio d'aria dal lato ventola. Nel caso di temperature ambiente <-5°C o >+40°C contattare il servizio Assistenza Tecnica.
- Il montaggio dei vari organi (pulegge, ruote dentate, giunti, alberi, ecc.) sugli alberi pieni o cavi deve essere eseguito utilizzando appositi fori filettati o altri sistemi che comunque garantiscano una corretta operazione senza rischiare il danneggiamento dei cusci netti o delle parti esterne dei gruppi.
- Lubrificare le superfici a contatto per evitare grippaggi o ossidazioni.
- La verniciatura non deve assolutamente interessare le parti in gomma e i fori esistenti sui tappi di sfiato, quando presenti.
- Per i gruppi provvisti di tappi per olio sostituire il tappo chiuso utilizzato per la spedizione con l'apposito tappo di sfiato.
- Controllare il corretto livello del lubrificante tramite, quando prevista, l'apposita spia. La messa in funzione deve avvenire in maniera graduale, evitando l'applicazione immediata del carico massimo.
- Quando sotto alla motorizzazione sono presenti organi, cose o materiali danneggiabili dall'eventuale fuoriuscita, anche limitata, di olio è opportuno prevedere un'apposita protezione.

FR

INSTALLATION

Pour garantir le bon fonctionnement des réducteurs et leur durée de vie maximum, il est indispensable d'assurer un bon accouplement à la structure sur laquelle le groupe doit être fixé. Aussi, les surfaces de cette structure doivent être usinées par des centrages en H8 et de façon à garantir une planéité optimale et une perpendicularité par rapport à l'axe du réducteur. Pour l'installation du réducteur, il faut se conformer aux indications suivantes:

- Pour les groupes installés à ciel ouvert, il est conseillé, dans la mesure du possible, de mettre les réducteurs à l'abri des intempéries, de les traiter avec des produits anti-corrosion et de protéger les joints d'étanchéité à l'aide de la graisse hydrofuge.
- Pour effectuer la fixation du réducteur, utiliser les boulons indiqués sous chaque dessin des fiches techniques du produit. En outre, utiliser tous les trous de fixation prévus sur les brides des réducteurs.
- L'assemblage des réducteurs aux moteurs principalement électriques ou hydrauliques, est généralement assuré par bridage direct en l'absence de conditions critiques particulières susceptibles d'endommager l'installation.
- La fixation sur la machine doit être stable pour éviter toute vibration.
- Avant le montage du groupe sur la machine, vérifier que le sens de rotation de l'arbre de sortie du réducteur soit correct.
- En cas de périodes de stockage particulièrement longues (4/6 mois), si la bague d'étanchéité n'est pas immergée dans le lubrifiant contenu à l'intérieur du groupe, on conseille son remplacement, car le caoutchouc pourrait être collé à l'arbre ou avoir perdu les caractéristiques d'élasticité nécessaires à un fonctionnement correct.
- Vérifier que le refroidissement du moteur soit suffisant, en assurant un bon passage d'air du côté ventilateur. En cas de températures ambiante <-5°C ou >+40°C, contacter le S.c.e techniques.
- Le montage de différents organes (poules, roues dentées, accouplements, arbres, etc.) sur les arbres pleins ou creux doit être effectué en utilisant les trous filetés ou d'autres systèmes assurant de toute façon une opération correcte, sans risquer d'endommager les roulements ou les parties extérieures des groupes. Lubrifier les surfaces en contact, afin d'éviter le grippage ou l'oxydation.
- La peinture ne doit absolument pas toucher les parties en caoutchouc et, si présents, les trous sur les bouchons d'évent.
- Pour les groupes avec bouchons d'huile, remplacer le bouchon, utilisé l'ors de l'expédition, par le bouchon d'évent.
- Contrôler, grâce au voyant (si prévu), que le niveau du lubrifiant correspond. La mise en marche doit s'effectuer d'une façon graduelle, en évitant l'application immédiate de la charge maximale.
- Si des organes, des choses ou des matériels pouvant être endommagés par l'éventuelle sortie d'huile, même si limitée, sont présents sous la motorisation, il faut prévoir une protection adéquate.

ES

INSTALACIÓN

Para garantizar un buen funcionamiento de los reductores y una mayor duración se deberá realizar un correcto acoplamiento a la estructura en la que se fija el grupo. Por tanto las superficies de dicha estructura tendrán que estar bien planas y los ejes de los agujeros respetar una tolerancia H8, de este modo se podrá garantizar una óptima planaridad y perpendicularidad con el eje del reductor. Para la instalación del reductor, atenderse a las siguientes indicaciones:

- Para los grupos instalados al aire libre se aconseja, donde sea posible, proteger los reductores contra la intemperie, tratarlos con sistemas contra la corrosión y proteger los sellos de lubricación con grasa hidrófuga.
- Pour effectuer la fixation du réducteur, utiliser les boulons indiqués sous chaque dessin des fiches techniques du produit. En outre, utiliser tous les trous de fixation prévus sur les brides des réducteurs.
- El montaje entre los reductores y los motores, principalmente eléctricos o hidráulicos, generalmente se realiza con embrizado directo siempre que no se presenten particulares condiciones críticas que podrían ocasionar daños después de la instalación.
- Para evitar las vibraciones, la fijación sobre la máquina tiene que ser estable.
- Antes del montaje del grupo sobre la máquina, controlar que el sentido de rotación del eje de salida del reductor sea correcto.
- En caso de periodos de almacenamiento muy largos (4/6 meses), si el retén no está sumergido en el lubricante contenido en el grupo, se aconseja su reemplazo porque la goma podría estar pegada al eje o haber perdido las características de elasticidad necesarias para un funcionamiento correcto.
- Controlar que la refrigeración del motor sea suficiente, asegurando una correcta transferencia de aire del lado ventilador. En caso de temperatura ambiente de <-5°C o >+40°C, ponerse en contacto con el Servicio técnico.
- El montaje de distintos órganos (poleas, ruedas dentadas, acoplamientos, ejes, etc.) sobre los ejes llenos o huecos debe ser efectuado utilizando los agujeros roscados correspondientes u otros sistemas, asegurando de todas maneras una operación correcta sin correr el riesgo de dañar los cojinetes o las partes externas de los grupos.
- Lubricar las superficies en contacto para evitar los gripados o las oxidaciones.
- El barnizado no debe cubrir las partes de goma y los agujeros en los existentes tapones - respiraderos. Para los grupos equipados de tapones de aceite, reemplazar el tapón cerrado, utilizado durante el transporte, por el tapón respiradero.
- Controlar, por medio del indicador (si previsto), que el nivel del lubricante corresponda. La puesta en marcha se debe producir de manera gradual evitando la aplicación súbita de la carga máxima.
- Si bajo el reductor hay mecanismos, cosas ó materiales que puedan dañarse por una eventual pérdida de aceite, deberá prevverse una protección adecuada.

TR RADYAL YÜKLER - TEKNİK TANIMLAR

Kabul edilebilir Radyal yük (N) değeri motorlu seçim sayfalarında ilgili tablolarda verilmiştir. Bu şaftın merkez hattına binen yüklerle ve en uygunsuz durumlarda uygulama açısı ve yönü ile ilgili bir olgudur.

Kombinasyonlu uygulamalarda max. müsaade edilen ek-senel yük radyal yükün 1/5'i kadar olmalıdır.

Çıkış şaftları ile ilgili olarak hazırlanan tablolarda max. kabul edilebilir değerler verilmiştir.

Gövde mukavemeti ile ilgili olduğundan bu değer çok aşıl-mamalıdır. Bazı istisnai durumlarda katalogta verilen yük değerleri aşılabılır. Bu durumda Teknik Servisimiz uygulama ile ilgili detay sağlar; yükün yönü, şaftın dönüş yönü, verilecek servisin tipi.

Çalıştırıldığında iki türlü enine kuvvet geldiği taktirde, kurulum çalışma koşuluna göre kontrol ediniz. Bu durum için teknik departmana başvurunuz.

Şaft üzerindeki radyal yük aşağıdaki formülle hesaplanır:

$$FR_{XL} = \frac{2000 \cdot M_2 \cdot fz}{d_o} \leq FR_1 \text{ o } FR_2$$

FR_{XL} (N)

İzin verilen radyal yük

M₂ (Nm)

Şaft üzerindeki moment

d_o (mm)

Şaft üzerine monte edilmiş transmisyon elemanın çapı

FR (N)

Uygulanan maksimum radyal yük değeri FR₁ - FR₂ (ilgili tablolara bakınız).

fz = 1,1 Dişliler
1,4 Zincir dişliler
1,7 v-makarası
2,5 Düz makara

Sonuç radyal yük şaftın merkez hattına uygulanmadığında aşağıdaki formülle etkin yükün hesaplanması gerekir:

$$FR_X = \frac{FR_1 - 2 \cdot z}{(y + x)}$$

y, z = sayfa 22' deki tablolarda verilen değerler

x = Yükün uygulandığı nokta ile çıkış mili faturası arasın-daki mesafe.

EN RADIAL LOADS - TECHNICAL DESCRIPTIONS

The value of the admissible radial load (N) is given in the tables relating to the performance of the reduction unit at is sue. It is related to the load applied on the centre line of the shaft and in the most unfavourable conditions of angle of application and direction of rotation.

The maximum admissible axial loads are 1/5 of the value of the given radial load when are applied in combination with the radial load.

The tables relating to the output shafts give the maximum admissible value. This value must never be exceeded since it relates to the strength of the case.

Particular conditions of radial load higher than the limits of the catalogue may occur. In this case, call our Technical Service and provide details on the application: direction of the load, direction of rotation of the shaft, type of service. In case of double extension shafts with radial load applied on both ends, the max. admissible radial loads must be defined according to the specific running conditions, in this case call our Technical Service.

The radial load on the shaft is calculated with the following formula:

$$FR_{XL} = \frac{2000 \cdot M_2 \cdot fz}{d_o} \leq FR_1 \text{ o } FR_2$$

FR_{XL} (N)

Resulting radial load

M₂ (Nm)

Torque on the shaft

d_o (mm)

Diameter of the transmission member mounted on the shaft

FR (N)

Value of the maximum admitted radial load FR₁ - FR₂ (see relative tables).

fz = 1,1 Gear pinion
1,4 Chain wheel
1,7 V-pulley
2,5 Flat pulley

When the resulting radial load is not applied on the centre line of the shaft it is necessary to adjust the admissible radial load FR₁₋₂ with the following formula:

$$FR_X = \frac{FR_1 - 2 \cdot z}{(y + x)}$$

y, z = values given in the tables on page 22.

x = distance from the point of application of the load to the shaft shoulder.

DE QUERBELASTUNGEN - TECHNISCHE BESCHREIBUNGEN

Der Wert der zulässigen Querbelastrung (N) wird in den Tafeln über die Leistungen des betreffenden Getriebes aufgeführt und ist die Kraft, die auf die Mittellinie der Wellen unter ungünstigsten Bedingungen wie Anwendungswinkel und Drehrichtung einwirkt.

Die zulässigen Axialbelastungen betragen 1/5 der aufgeführten Querbelastrungen, wenn diese gleichzeitig einwirken.

Die Tafeln über die Abtriebswellen geben den für die Lager bzw. das Gehäuse zulässigen Höchstwert an; dieser Wert darf nie überschritten werden.

Falls die im Katalog aufgeführten Grenzwerte doch überschritten werden sollten, setzen Sie sich bitte mit unserem Kundendienst in Verbindung und nennen Sie ihm alle Anwendungsdaten wie Belastungsrichtung, Drehrichtung der Welle, Anwendungsart.

Sofern die Anwendung mit einer beidseitigen Einleitung der Querkraft arbeitet, ist die Anwendung hinsichtlich der Einsatzbedingungen zu überprüfen. Hierzu kontaktieren Sie bitte unser technisches Büro.

Die Querbelastrung (Querkraft) auf der Welle wird durch nachstehende Formel berechnet:

$$FR_{XL} = \frac{2000 \cdot M_2 \cdot fz}{d_o} \leq FR_1 \text{ o } FR_2$$

FR_{XL} (N)

Resultierende Querkraft

M₂ (Nm)

Wellendrehmoment

d_o (mm)

Durchmesser des an der Welle montierten Antriebselements

FR (N)

Max. zul. Querkraft FR₁ - FR₂ (siehe entspr. Tafel).

fz = 1,1 Zahnrad
1,4 Rad für Kette
1,7 Flanschscheibe
2,5 Flachriemenscheibe

Sofern die resultierende Querkraft nicht auf die Mitte der Welle bezogen ist, ist die effektive Kraft FR₁₋₂ durch Formel zu berechnen:

$$FR_X = \frac{FR_1 - 2 \cdot z}{(y + x)}$$

y, z = siehe Tafeln auf seite 22.

x = Abstand der Querkraft zur Wellenschulter.

IT CARICHI RADIALI - DESCRIZIONI TECNICHE

Il valore del carico radiale (N) ammissibile viene riportato nelle tabelle relative alle prestazioni del riduttore in same, ed è relativo al carico applicato sulla mezzeria dell'albero e nelle condizioni più sfavorevoli come angolo di applicazione e senso di rotazione.

I carichi assiali massimi ammissibili sono 1/5 del valore del carico radiale indicato quando sono applicati in combinazione col carico radiale stesso.

Nelle tabelle relative agli alberi di uscita viene indicato il valore massimo ammissibile, questo valore non deve mai essere superato in quanto è relativo alla resistenza della cassa. Possono essere verificate condizioni particolari di carico radiale superiori ai limiti di catalogo, in questo caso contattare il ns. Servizio Tecnico.

Servizio Tecnico e fornire tutti i dati applicativi: direzione del carico, senso di rotazione dell'albero, tipo di servizio.

Nel caso di alberi bisporgenti e cavi in cui è previsto l'applicazione di carichi radiali su entrambe le estremità, i carichi massimi ammissibili sono da definire in funzione delle condizioni di esercizio specifiche, in questo caso contattare il ns. Servizio Tecnico.

Il carico radiale sull'albero si calcola con la seguente formula:

$$FRXL = \frac{2000 \cdot M_2 \cdot fz}{do} \leq FR1 \text{ o } FR2$$

FRXL (N)
Carico radiale risultante
M2 (Nm)
Momento torcente sull'albero
do (mm)
Diametro dell'elemento di trasmissione montato sull'albero
FR (N)
Valore di carico radiale massimo ammesso FR1 - FR2 (ved. tab.relative)

fz = 1,1 Pignone dentato
1,4 Ruota per catena
1,7 Puleggia a gola
2,5 Puleggia piana

Quando il carico radiale risultante non è applicato in mezzeria dell'albero occorre correggere il carico radiale ammissibile FR1-2 con la seguente formula:

$$FRX = \frac{FR1 - 2 \cdot z}{(y + x)}$$

y, z = valori riportati nelle tabelle pag. 22
x = distanza del punto di applicazione del carico da spallamento albero.

FR CHARGES RADIALES - DESCRIPTIONS TECHNIQUES

La valeur de la charge radiale (N) admissible est indiquée dans les tableaux concernant les performances du réducteur examiné et correspond à la charge appliquée sur la ligne médiane de l'arbre, dans les conditions les plus défavorables au niveau de l'angle d'application et du sens de rotation.

Les charges axiales maximales admissibles sont 1/5 de la valeur de la charge radiale indiquée, au cas où elles seraient appliquées en combinaison avec la charge radiale même.

Les tableaux concernant les arbres de sortie indiquent la valeur maximale admissible, valeur qui ne doit jamais être dépassée car elle correspond à la résistance de la carcasse. Des conditions particulières de charges radiales supérieures aux limites de catalogue peuvent être vérifiées; dans ce cas, contacter notre S.ce Technique en donnant toutes les données d'application: direction de la charge, sens de rotation de l'arbre, type de service.

Dans le cas d'arbre double avec une charge radiale appliquée aux deux extrémités, la charge radiale maxi admissible doit être définie selon les conditions de fonctionnement spécifiques, dans ce cas contacter notre service technique.

La charge radiale sur l'arbre doit être calculée selon la formule suivante:

$$FRXL = \frac{2000 \cdot M_2 \cdot fz}{do} \leq FR1 \text{ o } FR2$$

FRXL (N)
Charge radiale résultante
M2 (Nm)
Torque on the shaft
do (mm)
Diameter of the transmission member mounted on the shaft
FR (N)
Valeur de charge radiale maximum admise FR1 - FR2 (voir table aux correspondants)

fz = 1,1 Pignone denté
1,4 Roue pour chaîne
1,7 Pouille à gorge
2,5 Pouille plate

Quand la charge radiale résultante n'est pas appliquée au milieu de l'arbre, il est nécessaire de corriger la charge radiale admissible FR1-2 avec la formule suivante:

$$FRX = \frac{FR1 - 2 \cdot z}{(y + x)}$$

y, z = valeurs indiquées dans les tableaux à page 22.
x = distance entre le point d'application de la charge et l'épaule - ment de l'arbre.

ES CARGAS RADIALES - DESCRIPCIONES TECNICAS

El valor de carga radial (N) admisible es indicado en las tablas relacionadas a las prestaciones del reductor examinado y se refiere a la carga aplicada sobre la línea de centro del eje y en las condiciones más desfavorables como ángulo de aplicación y sentido de rotación.

Las cargas axiales máximas admisibles son 1/5 del valor de carga radial indicado, cuando están aplicadas en combinación con la carga radial misma.

En las tablas relacionadas a los ejes de salida se indica el valor máximo admisible; nunca se debe superar este valor, porque se refiere a la resistencia de la carcasa.

Podrían presentarse condiciones particulares de carga radial superiores a los límites de catálogo; en este caso, ponerse en contacto con nuestro Servicio técnico e indicar todos los datos de la aplicación: dirección de carga, sentido de rotación del eje, tipo de servicio.

En caso de ejes dobles o huecos sobre los que se prevea la aplicación de cargas radiales sobre ambos extremos, las cargas máximas admisibles se deben definir en función de las características de la aplicación, en ese caso contactar a nuestro Servicio Técnico.

La carga radial sobre el eje se calcula con la siguiente fórmula:

$$FRXL = \frac{2000 \cdot M_2 \cdot fz}{do} \leq FR1 \text{ o } FR2$$

FRXL (N)
Carga radial resultante
M2 (Nm)
Par de torsión sobre el eje
do (mm)
Diamètre de l'élément de transmission monté sur l'arbre
FR (N)
Valor de carga radial máximo admitido FR1 - FR2 (ver tablas correspondientes)

fz = 1,1 Piñon dentado
1,4 Piñon de cadena
1,7 Polea para correa trapezoidal
2,5 Polea plana

Quando la carga radial resultante no se aplica sobre el centro del eje de salida, se debe corregir la carga radial admisible FR1-2 mediante la siguiente fórmula:

$$FRX = \frac{FR1 - 2 \cdot z}{(y + x)}$$

y, z = valores indicados en las tablas pag. 22.
x = distancia desde el punto de aplicación de la carga hasta la base del eje.

TR RADYAL YÜKLER - TEKNİK TANIMLAR

EN RADIAL LOADS - TECHNICAL DESCRIPTIONS

DE QUERBELASTUNGEN - TECHNISCHE BESCHREIBUNGEN

IT CARICHI RADIALI - DESCRIZIONI TECNICHE

FR CHARGES RADIALES - DESCRIPTIONS TECHNIQUES

ES CARGAS RADIALES - DESCRIPCIONES TECNICAS

Çıkış Şaftı

Radyal kuvvet çıkış şaftının orta noktasına gelmediğinde kabul edilebilir radyal yük FRX2 aşağıdaki formül ile hesaplanır.

Alberi in Uscita

Con carico radiale risultante non in mezziera dell'albero, correggere il carico radiale ammissibile FRX2 con la formula:

Output Shafts

When the radial load is not on the centre line of the shaft, it is necessary to adjust the admissible radial load FRX2 with the following formula:

Arbres de Sortie

Quand la charge radiale n'est pas au milieu de l'arbre, il est nécessaire de corriger la charge radiale admissible FRX2 avec la formule suivante:

Abtriebswellen

Sofern die radiale Querkraft nicht auf die Mitte der Welle bezogen ist, ist die effektive zulässige Kraft FRX2 durch folgende Formel zu berechnen:

Ejes de Salida

Si la carga radial resultante no se aplica sobre el centro del eje, corregir la carga radial admissible FRX2 mediante la siguiente fórmula:

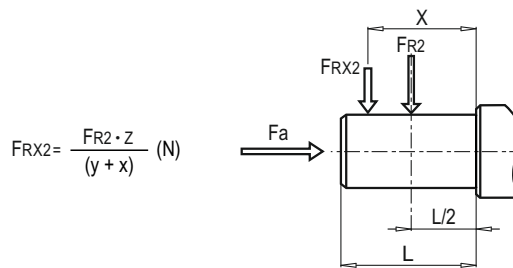

A/F	301	351	401	501	601	701
z	89	98	115	151	210	232
y	79	73	85	111	155	177
FR2 (a) max**	1000	2500	3700	4000	5000	6000
Fa max (*)	5500	6500	7000	8500	11500	13500

A/F	202	202 G	252-253	302-303	352-353	402-403	502-503	602-603	702-703	902-903
z	86,5	103	120	138	169	195	238	281	331	367
y	66,5	83	96	108	134	155	188	221	261	282
FR2 (a) max**	2500	2800	5500	6600	8000	12000	18000	22000	30000	55000

(**FR2) Redüktörün kabul edilen max. değerini performans tablolarından doğrulayınız.

(**FR2) Max. admissible value of the reducer; verify max. admissible value on performance tables.

(**FR2) Entspricht dem max. zulässigen Getriebewert; bitte beachten sie den max. Wert de Tabelle.

(**FR2) Valore massimo ammesso dal riduttore; verificare valore massimo ammesso su tabelle di prestazioni.

(**FR2) Valeur maximale admissible du réducteur; vérifier la valeur maxi admissible dans les tableaux de performances.

(**FR21) Valor máximo admisible por el reductor; verificar el valor máximo admisible en las tablas de prestaciones.

(*) Tek yönlü maksimum aksel yük değerleri bir basma yatağı kullanılarak (talebe bağlı) kabul edilebilir.

(*) Maximum axial load values admissible in only one direction with the use of a thrust bearing (on request).

(*) Die Werte der maximal zulässigen Axialkräfte beziehen sich auf eine Drehrichtung bei verbautem Axiallager (auf Anfrage).

(*) Valori di carico assiale massimo ammissibile in una sola direzione per versione con cuscinetto reggispinta (a richiesta).

(*) Valeurs de charge axiale maximum admissible dans une seule direction pour la version avec roulements coniques (sur demande).

(*) Valores de la fuerza axial maxima admisible en un unico sentido con rodamiento axial (bajo demanda).

TR RADYAL YÜKLER - TEKNİK TANIMLAR

EN RADIAL LOADS - TECHNICAL DESCRIPTIONS

DE QUERBELASTUNGEN - TECHNISCHE BESCHREIBUNGEN

IT CARICHI RADIALI - DESCRIZIONI TECNICHE

FR CHARGES RADIALES - DESCRIPTIONS TECHNIQUES

ES CARGAS RADIALES - DESCRIPCIONES TECNICAS

Giriş Şaftı

Radyal kuvvet giriş şaftının orta noktasına gelmediğinde kabul edilebilir radyal yük FRX1 aşağıdaki formül ile hesaplanır.

Input Shafts

When the radial load is not on the centre line of the shaft, it is necessary to adjust the admissible radial load FRX1 with the following formula:

Antriebswellen

Sofern die radiale Querkraft nicht auf die Mitte der Welle bezogen ist, ist die effektive zulässige Kraft FRX1 durch folgende Formel zu berechnen:

Alberi in Entrada

Con carico radiale risultante non in mezzera dell'albero, correggere il carico radiale ammissibile FRX1 con la formula:

Arbres D'entree

Quand la charge radiale n'est pas au milieu de l'arbre, il est nécessaire de corriger la charge radiale admissible FRX1 avec la formule suivante:

Ejes de Entrada

Si la carga radial resultante no se aplica sobre el centro del eje, corregir la carga radial admissible FRX1 mediante la siguiente fórmula:

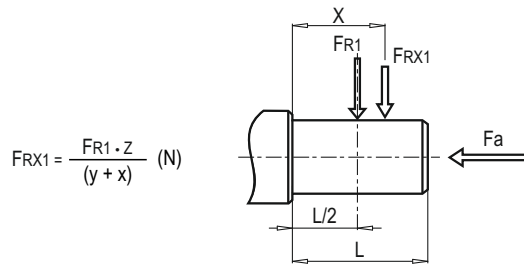

A/F - W	301	351	401	501	601	701
z	105	105	105	137	175	175
y	80	80	80	108	135	135
FR1 (a) max**	1320	1800	2200	2500	3000	3000

A/F - W	202	202 G	252-253	302-303	352-353	402-403	502-503	602-603	702-703	902-903
z	-	-	105	105	105	137	137	175	175	225
y	-	-	80	80	80	108	108	135	135	170
FR1 (a) max**	-	-	2200	2200	2500	3600	3600	7200	7200	15000

(**FR1) Redüktörün kabul edilen max. değerini performans tablolarından doğrulayınız.

(**FR1) Max. admissible value of the reducer; verify max. admissible value on performance tables.

(**FR1) Entspricht dem max. zulässigen Getriebewert; bitte beachten sie den max. Wert de Tabelle.

(**FR1) Valore massimo ammesso dal riduttore; verificare valore massimo ammesso su tabelle di prestazioni.

(**FR1) Valeur maximale admissible du réducteur; vérifier la valeur maxi admissible dans les tableaux de performances.

(**FR1) Valor máximo admisible por el reductor; verificar el valor máximo admisible en las tablas de preestaciones.

TR ATALET MOMENTİ

Aşağıdaki değerler sadece gösterge niteliğindedir ve PAM girişli redüktörler içindir. Bu değerler, maximum atalet momentini ifade eder.

EN MOMENTS OF INERTIA

Following values are indicative only and refer to gear reducers fitted with input PAM.
These values refer to maximum moment of inertia.

DE MASSENTRÄGHEITSMOMENTE

Die angegebenen Werte sind Richtwerte und beziehen sich auf Getriebe mit PAM Eingangsfansch.
Die angegebenen Werte beziehen sich jeweils auf das max. Massenträgheitsmoment.

IT MOMENTI D'INERZIA

I seguenti valori sono solo indicativi. Sono riferiti a riduttori già predisposti con l'attacco motore PAM.
I valori in tabelle sono riferiti al massimo di quelli calcolati.

FR MOMENTS D'INERTIE

Les valeurs suivantes sont seulement indicatives et se rapportent à des réducteurs de vitesse équipés avec l'entrée PAM.
Ces valeurs sont relatives au moment d'inertie maximum.

ES MOMENTOS DE INERCIA

Los valores siguientes son sólo indicativos y se refieren a los reductores con PAM de entrada.
Estos valores están referidos al momento de inercia máximo.

A - F - AF	J*1E-4 [Kg*m ²]
202	-
202 G	-
252 - 253	0,7
301	0,8
302 - 303	0,7
351	1,9
352 - 353	0,9
401	4,6
402 - 403	2,0
502 - 503	6,8
501	11,0
602 - 603	10,6
601	34,5
702 - 703	28,2
701	76,4
902 - 903	44,2

TR YAĞLAMA

Tabloda belirtilmeyen aşırı ısı ortamlarında Teknik Servisimizi arayınız.

-30 C° altındaki bir ısı değerinde veya 60 C° üzerindeki bir ısı değerinde hassas özelliklere sahip yağ keçesi kullanmak gerekir.

0 C°'nin altındaki sıcaklık değerlerinde çalışmak gerekiyor-şa aşağıdakileri göz önünde tutmak gerekir:

- 1- Motorlar tahmin edilen ortam sıcaklıklarındaki operasyonlara uygunluk gerektirir.
- 2- Elektrik motorunun gücü gerekli olan yüksek başlama tork değerlerini aşabilmesi için yeterli olmalıdır.
- 3- Redüktörlerin dökme demirden imal edildiği durumlarda -15 C° sıcaklığın altında dökme demirin kırılma riski bulunduğundan darbe yüklerine özen gösterin.
- 4- Servis hizmetinin ilk aşamalarında yağın sahip olduğu aşırı akışkanlık olayından dolayı birtakım yağlama problemleri meydana gelebilir, bu durumda yüksüz olarak birkaç dakika boyunca çalıştırmak gerekir.

Yağ değişimi yaklaşık 10.000 saatlik kullanımdan sonra yapılmalıdır. Bu süre servis tipine ve redüktörün çalıştığı ortama göre değişir.

EN LUBRICATION

In cases of ambient temperatures not envisaged in the table, call our Technical Service.

In the case of temperatures under -30°C or over 60°C it is necessary to use oil seals with special properties.

For operating ranges with temperatures under 0°C it is necessary to consider the following:

- 1- The motors need to be suitable for operation at the envisaged ambient temperature.
- 2- The power of the electric motor needs to be adequate for exceeding the higher starting torques required.
- 3- In case of cast - iron gear reducers, pay attention to impact loads since cast iron may have problems of fragility at temperatures under -15°C.
- 4- During the early stages of service, problems of lubrication may arise due to the high level of viscosity taken on by the oil and so it is wise to have a few minutes of rotation under no load.

The oil needs to be changed after approximately 10,000 hours. This period depends on the type of service and the environment where the reduction unit works.

DE SCHMIERUNG

Bei in der Tafel nicht vorgesehenen Umgebungstemperaturen setzen Sie sich bitte mit unserem Kundendienst in Verbindung.

Bei Temperaturen unter -30°C oder über 60°C werden Dichtringe aus besonderen Elastomeren benötigt.

Bei Betrieb mit Temperaturen unter 0°C ist folgendes zu berücksichtigen:

- 1- Die Motoren müssen für den Betrieb mit der vorgesehenen niedrigen Raumtemperatur geeignet sein.
- 2- Die Leistung des Elektromotors muss so ausgelegt werden, dass die höheren benötigten Anlaufdrehmomente aufgebracht werden können.
- 3- Bei Getriebegehäusen aus Guß sind die Stoßbelastungen zu beachten, weil der Guß bei Temperaturen unter -15°C verspröden könnte.
- 4- Bei Betriebsbeginn könnten Schmierungsprobleme infolge der hohen Ölviskosität auftreten, daher ist es sinnvoll, für einige Minuten einen Leerlauf auszuführen.

Je nach Umgebungsbedingungen und Betriebsart ist nach etwa 10.000 Betriebsstunden ein Ölwechsel durchzuführen.

IT LUBRIFICAZIONE

Nei casi con temperature ambiente non previste in tabella contattare il ns. Servizio Tecnico.

In caso di temperature inferiori a -30°C o superiori a 60°C occorre utilizzare anelli di tenuta con mescole speciali.

Per i campi di funzionamento con temperature inferiori a 0°C occorre considerare quanto segue:

- 1- I motori devono essere idonei al funzionamento con temperatura ambiente prevista.
- 2- La potenza del motore elettrico deve essere adeguata al superamento delle aggiori coppie di avviamento richieste.
- 3- Nel caso di riduttori con cassa in ghisa prestare attenzione ai carichi d'urto in quanto la ghisa può presentare problemi di fragili lità a temperature inferiori ai -15°C.
- 4- Durante le prime fasi di servizio possono insorgere problemi di lubrificazione cause l'elevata viscosità che assume l'olio e quindi è opportuno procedere ad alcuni minuti di rotazione a "vuoto".

Il cambio olio deve essere eseguito dopo circa 10.000 ore, questo periodo è in funzione del tipo di servizio e dell'ambiente in cui opera il riduttore.

FR LUBRIFICATION

En cas de températures ambiantes non prévues dans le tableau, contacter notre S.ce Technique.

En cas de température au-dessous de -30°C ou au-dessus de 60°C, il faut utiliser des bagues d'étanchéité avec mélanges spéciaux.

Pour les champs de fonctionnement avec température au-dessus de 0°C, il faut considérer ce qui suit:

- 1- Les moteurs doivent être aptes au fonctionnement à la température ambiante prévue.
- 2- La puissance du moteur électrique doit être au dépassement de la plupart des couples de démarrage demandés.
- 3- En cas de réducteurs avec carcasse en fonte, faire attention aux charges de choc, car la fonte peut présenter des problèmes de fragilité à températures au-dessous de -15°C.
- 4- Lors des premières phases de service, des problèmes de lubrification dus à la viscosité élevée, que l'huile assume, pourraient se vérifier; il faut donc procéder à une rotation "à vide" de quelques minutes.

Le changement d'huile doit être effectué après 10,000 heures environ; cette période est en fonction du type de service et du milieu dans lequel le réducteur travaille.

ES LUBRICACIÓN

En caso de temperaturas no previstas en la tabla, ponerse en contacto con nuestro Servicio técnico.

En caso de temperaturas inferiores a -30°C o superiores a 60°C, es necesario utilizar anillos de retén con mezclas especiales.

Para los campos de funcionamiento con temperaturas inferiores a 0°C, es necesario cumplir con lo que sigue:

- 1- Los motores tienen que ser idóneos al funcionamiento con la temperatura ambiente prevista.
- 2- La potencia del motor eléctrico tiene que ser idónea para superar los mayores pares de arranque pedidos.
- 3- En caso de reductores con carcasa de fundición, cuidado con las cargas de choque porque la fundición puede presentar problemas de fragilidad con temperaturas inferiores a los -15°C.
- 4- Durante las primeras fases de servicio podrían surgir unos problemas de lubricación debidos a la elevada viscosidad del aceite y es por lo tanto oportuno efectuar una rotación en "vacío" por algunos minutos.

El cambio de aceite tiene que ser efectuado aproximadamente después de 10.000 horas; claramente, este periodo es en función del tipo de ambiente en el que trabaja el reductor.

TR	YAĞLAMA	EN	LUBRICATION	DE	SCHMIERUNG
IT	LUBRIFICAZIONE	FR	LUBRIFICATION	ES	LUBRICACIÓN

Mineral Yağ / Mineral Oil / Mineralöl / Olio Minerale / Huile Minérale / Aceite Mineral							
	T°C ISO SAE...	ENI	SHELL	KLUBER	MOBIL	CASTROL	BP
A/F 301-701 A/F 202-902 A/F 253-903	(-5) / (+40) ISO VG220	BLASIA 220	OMALA OIL220	KLUBEROIL GEM 1-220N	MOBILGEAR 600 XP 220	ALPHA MAX 220	ENERGOL GR-XP220
	(-15) / (+25) ISO VG150	BLASIA 150	OMALA OIL150	KLUBEROIL GEM 1-150N	MOBILGEAR 600 XP 150	ALPHA MAX 150	ENERGOL GR-XP150

- Yağlayıcılar ile ilgili özellikler PGR Drive Technologies tarafından tavsiye edilmektedir.
- Specifications of lubricants recommended by PGR Drive Technologies.
- Spezifische Schmierstoffangaben erfragen Sie bei PGR Drive Technologies.
- Specifiche dei lubrificanti consigliati da PGR Drive Technologies.
- Especificaciones de lubricante aconsejados por PGR Drive Technologies.
- Spécification des lubrifiants suivant PGR Drive Technologies.

- Yağ miktarı için ilgili sayfalara bakınız. (sayfa 28)
- For the quantity of oil, please refer to the pages relating. (page 28)
- Für die Ölmenge siehe Seite 28.
- Per le quantità di olio si rimanda alle pagine relative. (pagina 28)
- Pour les quantités d'huile, voir pages concernant. (page 28)
- Para las cantidades de aceite, ver a las páginas. (página 28)

Özel yağlayıcılar / Special lubricants / Spezialschmierstoffe / Lubrificanti speciali / Lubrifiants spéciaux / Lubricantes especiales

		*T°C	Sentetik yağ / Synthetic oil / Synthetisches Öl / Olio sintetico / Huile synthétique / Aceite sintético
Düşük sıcaklık için yağlar Oils for low temperature Öle für niedrige Temperaturen Oli per basse temperature Huiles pour basse température Aceites para bajas temperaturas	ENI	(-25) - (+20)	BLASIA 150 S (ISO VG150)
	KLUBER	(-35) - (+10)	KLUBERSYNTH GH 6-80 (ISO VG68)
	MOBIL	(-40) - (+5)	SCH 624 (ISO VG32)
	KLUBER	(-40) - (+5)	KLUBERSYNTH GH 6-32 (ISO VG32)
Düşük sıcaklık için yağlar - Gıda sektörü Oils for low temperature - Food sector Öle für niedrige Temperaturen - Food-Sektor Oli per basse temperature - Settore alimentare Huiles pour basse température - Secteur de l'alimentation Aceites para bajas temperaturas - Sector alimentario	KLUBER	(-30) - (+10)	KLUBERSYNTH UH1-6 100 (ISO VG100)
Yüksek sıcaklık için yağlar / Oils for high temperature / Öle für hohe Temperaturen / Oli per alte temperature / Huiles pour haute température / Aceites de alta temperatura	KLUBER	(-10) - (+50)	KLUBERSYNTH GH 6-460 (ISO VG460)
	KLUBER	(-10) - (+70)	KLUBERSYNTH GH 6-680 (ISO VG680)
Yüksek sıcaklık için yağlar - Gıda sektörü Oils for high temperature - Food sector Öle für hohe Temperaturen - Food-Sektor Oli per alte temperature - Settore alimentare Huiles pour haute température - Secteur de l'alimentation Aceites de alta temperatura - Sector alimentario /	KLUBER	(-10) - (+50)	KLUBERSYNTH UH1-6 460 (ISO VG460)
Gıda sektörü / Food sector / Food-Sektor / Settore alimentare / Secteur de l'alimentation / Sector alimentario	KLUBER	(-15) - (+40)	KLUBERSYNTH UH1-6 220 (ISO VG220)

'Özel' yağlayıcı gerekiyorsa Teknik Yardım için lütfen irtibata geçiniz
If 'special' lubricant is required please contact for Technical Assistance
Falls spezielles Öl verwendet werden soll kontaktieren sie bitte unseren Kundendienst
Per l'utilizzo di lubrificanti speciali, contattare l'assistenza tecnica
Si un Lubrifiant spécial est demandé, merci de contacter notre service technique.
Para el uso de lubricantes especiales contactar con la asistencia técnica

- * Çalışma ortam sıcaklığı
- * Working ambient temperature
- * Betriebsumgebungstemperatur
- * Temperatura ambiente di funzionamento
- * Température ambiante de fonctionnement
- * Temperatura ambiente de funcionamiento

TR

YAĞLAMA

- A/F serisi redüktörlerin montaj pozisyonu verilmelidir.
- A/F serisi 1 kademe 30, 35, 40 ve 2,3 kademe 25, 30, 35 gövde redüktörler yağ içine konmuş vaziyette gönderilir. Redüktörler herhangi bir bakıma gerek duymamakta ve fabrika çıkışlı yağ tapası ile verilir.
- A/F serisi redüktörlerin 1 kademe 50, 60, 70 ve 2,3 kademe 40, 50, 60, 70, 90 gövde büyüklükleri montaj pozisyonları istenildiği gibi yapılabilir.
İstek üzerine redüktörler tarafımızca gres yağlı verilebilir, bu durumda yağ tapası ile gönderilen redüktörü havalandırma tapası ile değiştirmesini tavsiye ederiz. Redüktör yağsız istendiğinde istenilen montaj pozisyonuna göre yağ dolumu yapılmalıdır, bu tabloları katalogda bulabilirsiniz veya bize danışınız.
Verilen yağ miktarları montaj pozisyonuna göre değişiklik gösterir ve yağ göstergesi, yada yağ çubuğu (tipe göre) ile sürekli kontrol edilmesi gerekir. Yağ seviye değişikliği farklı montaj pozisyonlarına göre değişir. Montaj-demontaj dan sonra yağ seviyeleri kontrol edilmeli ve duruma göre ilave yağ konulması gerekebilir.

EN

LUBRICATION

- For the reduction units A/F series it is always necessary to specify the mounting position.
- A/F 1 stage 30, 35, 40 and 2,3 stage 25, 30, 35, are supplied complete with lubricant, have no oil plugs and need no maintenance
- The gear reducer A/F series 1 stage 50, 60, 70 and 2,3 stage 40, 50, 60, 70, 90 are supplied complete with lubricant and are fitted with oil plugs to suit any mounting position included in the catalogue.
It is recommended, after installation, to replace the closed plug used for transportation with the supplied breather plug. Lubricant quantities are only indicative, For correct filling always refer to the sight glass or the dipstick, when this is supplied.
Any oil level differences can be caused by constructive tolerances but also on the mounting position or the assembly scheme of the customer Therefore it is very important for the customer to check oil level and if necessary to add the necessary quantity.

DE

SCHMIERUNG

- Für die Getriebe der Serie A/F ist die Einbaulage anzugeben.
- Getriebe der Serie A/F mit 1 Übersetzungsstufe in den Baugrößen 30, 35, 40 und mit 2,3 Übersetzungsstufen in den Baugrößen 25, 30, 35, werden werkseitig mit Schmieröl befüllt. Sie bedürfen keinerlei Wartung und sind serienmäßig mit Ölstopfen ausgestattet.
- Die Getriebe der Serie A/F mit 1 Übersetzungsstufe in den Baugrößen 50, 60, 70 und mit 2,3 Übersetzungsstufen in den Baugrößen 40, 50, 60, 70, 90 werden werkseitig mit Schmieröl, sowie Ölstopfen ausgeliefert. Die erforderliche Ölmenge und die Positionen der Öl-schaugläser entsprechen der werkseitig vorgeschlagenen Position. Vor der Inbetriebnahme sind die Verschlussstopfen, durch entsprechende Entlüftungsventile, gemäß der Einbaulage, auszutauschen.
Die angegebenen Ölmenge sind Richtwerte. Diese müssen je nach Einbaulage, über Öl-schaugläser, Ölstandsbohrungen der Ölmesstäbe (je nach Typ) regelmässig überprüft werden. Ölstandsunterschiede können aus verschiedenen Einbaulagen resultieren.
Nach jeder Montage, sind alle Ölstände zwingend zu prüfen und gegebenenfalls anzupassen.

IT

LUBRIFICAZIONE

- Per i riduttori serie A/F occorre sempre specificare la posizione di piazzamento prevista.
- Serie A/F 1 stadio nelle grandezze 30,35,40 e serie A/F 2,3 stadi nelle grandezze 25,30,35 vengono forniti completi di lubrificante sono sprovvisti dei tappi olio e non hanno necessità di alcuna manutenzione
- I riduttori serie A/F a 1 stadio nelle grandezze 50,60,70 e a 40,50,60,70,90 vengano forniti completi di lubrificante a dei tappi olio necessari a garantire la corretta lubrificazione nella posizione di piazzamento richiesta.
Si raccomanda, effettuata l'installazione, di sostituire il tappo chiuso utilizzato per il trasporto con il tappo di sfato fornito a corredo.
Le quantità di olio in tabella sono solo indicative e per il corretto riempimento si dovrà fare riferimento al tappo o all'astina di livello, se presente.
Eventuali scostamenti di livello possono dipendere da tolleranze costruttive ma anche dal piazzamento del riduttore o dal piano di montaggio presso cliente. Per tale motivo è opportuno che il cliente verifichi e, se necessario, ristabilisca il livello a riduttore installato.

FR

LUBRIFICATION

- Pour les réducteurs série A/F il faut toujours spécifier la position de montage.
- Série A/F à 1 train pour les grandeurs, 30,35,40 et série A/F 2,3 trains pour les grandeurs 25,30,35 sont fournis avec lubrifiant et sans bouchons et ne nécessitent, donc, aucun entretien.
- Les réducteurs série A/F à 1 train pour les grandeurs 50,60, 70 et à 2,3 trains pour les grandeurs 40,50,60,70,90 sont fournis avec tous les bouchons nécessaires pour garantir toutes les positions de montage prévues au catalogue.
On recommande, après l'installation, de changer le bouchon livré pour le transport contre celui fourni avec trou d'évent.
Les quantités d'huile indiquées en tableau sont seulement indicatives et pour un remplissage correct il faut faire référence au bouchon de niveau ou à la jauge à huile, si présents.
Toutes les différences de niveau d'huile peuvent être causées par des tolérances de constructions, ou par la position de montage, ou le schéma d'assemblage du client. Par conséquent il est très important que le client vérifie le niveau d'huile et au besoin ajoute la quantité nécessaire.

ES

LUBRICACIÓN

- Para los reductores serie A/F es necesario especificar siempre la posición de montaje.
- Serie A/F de 1 tren en los tamaños, 30,35,40 y serie A/F de 2,3 trenes en los tamaños, 25,30,35 se suministran con lubricante, no disponen de tapón aceite y no necesitan ningún mantenimiento.
- Los reductores serie A/F de 1 tren en los tamaños 50,60,70 y de 2,3 trenes en los tamaños 40,50,60,70,90 se suministran con lubricante y disponen de tapones para todas las posiciones de montaje previstas en el catálogo.
Es necesario, una vez instalado el reductor en la máquina, sustituir el tapón cerrado, utilizado durante el transporte, por el tapón respiradero que se adjunta.
Las cantidades de lubricante en la tabla son indicativas y para un correcto llenado hay que tomar de referencia el centra del visor o del asta de nivel si están instaladas.
Eventuales diferencias del nivel de aceite pueden depender de tolerancias constructivas perotambién de la posición de montaje o del esquema de montaje del cliente. Por tanto es muy importante que el cliente compruebe el nivel de aceite y si es necesario agregue la cantidad adecuada.

TR YAĞLAMA
IT LUBRIFICAZIONE

EN LUBRICATION
FR LUBRIFICATION

DE SCHMIERUNG
ES LUBRICACIÓN

- Litre cinsinden yağ miktarı ~ / Quantity of oil in litres ~ / Ölmenge (Liter) ~ / Quantità olio in litri ~ / Quantité d'huile en litres ~ / Cantidad de aceite en litros ~

	Tip / Type / Typ Tipo / Type / Tipo	M1	M2	M3	M4	M5	M6
	A/F 202	0.16	0.32	0.21	0.23	0.23	0.23
	A/F 202 G	0.30	0.59	0.42	0.50	0.42	0.42

- Litre cinsinden yağ miktarı ~ / Quantity of oil in litres ~ / Ölmenge (Liter) ~ / Quantità olio in litri ~ / Quantité d'huile en litres ~ / Cantidad de aceite en litros ~

	Tip / Type / Typ Tipo / Type / Tipo	M1	M2	M3	M4	M5	M6
	A/F 301	0.50	0.35	0.20	0.50	0.35	0.35
	A/F 351	0.60	0.45	0.25	0.65	0.45	0.45
	A/F 401	0.75	0.45	0.40	0.90	0.60	0.60
	A/F 501	1.45	1.50	1.50	1.50	1.50	1.50
	A/F 601	3.80	3.20	1.30	2.70	2.60	2.60
	A/F 701	5.70	4.00	2.30	6.50	4.00	4.00

- Litre cinsinden yağ miktarı ~ / Quantity of oil in litres ~ / Ölmenge (Liter) ~ / Quantità olio in litri ~ / Quantité d'huile en litres ~ / Cantidad de aceite en litros ~

	Tip / Type / Typ Tipo / Type / Tipo	M1	M2	M3	M4	M5	M6
	A/F 252 - 253	0.80	1.20	1.10	1.30	1.00	1.00
	A/F 302 - 303	1.20	1.70	1.30	1.70	1.20	1.20
	A/F 352 - 353	1.50	2.00	1.80	2.20	1.80	1.80
	A/F 402 - 403	3.00	4.40	3.60	4.10	3.40	3.40
	A/F 502 - 503	5.70	7.90	6.20	7.80	6.60	6.60
	A/F 602 - 603	10.00	14.30	11.20	13.40	11.00	11.00
	A/F 702 - 703	16.70	22.20	16.90	21.20	18.20	18.20
	A/F 902 - 903	29.00	40.00	28.50	34.50	27.50	27.50

Not: AF-M gövdelerde, M1 ile M3 montaj pozisyonları yer değiştirmektedir

Note: M1 and M3 mounting positions are changed in AF-M bodies

Anmerkung: M1 und M3 die montagepositionen werden in AF-M körpern geändert

Note: Le posizioni di montaggio M1 e M3 vengono modificate negli corpo AF-M

Notes: Les positions de montage M1 et M3 sont modifiées dans les corps AF-M

Notas: Las posiciones de montaje M1 y M3 se cambian en cuerpos AF-M.

TR MONTAJ POZİSYONLARI
IT PIAZZAMENTO

EN MOUNTING POSITIONS
FR POS. DE MONTAGE

DE EINBAULAGE
ES POS. DE MONTAJE

AF
AF 202
AF 202 G

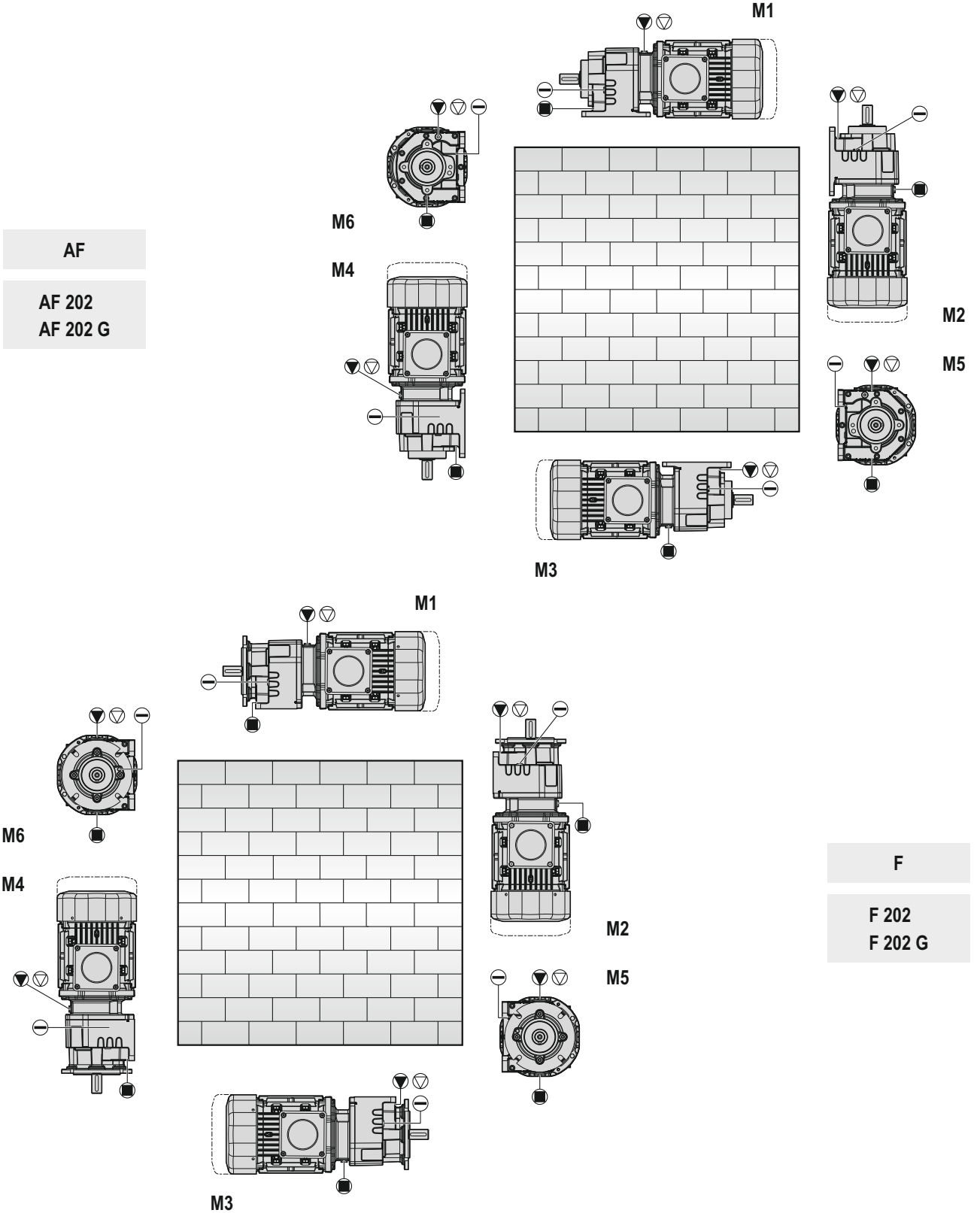

○ Havalandırma tapası / Vent plug /
Entlüftung / Tappo di sfiato /
Évent / Ventilación

● Doldurma tapası / Filling plug /
Einfüllstopfen / Tappo carico /
Bouchon remplissage / Tapón de carga

○ Yağ Seviye tapası / Oil level /
Ölstand / Tappo di livello dell'olio /
Niveau d'huile / Nivel de aceite

● Boşaltma tapası / Drain plug /
Ölablass / Tappo di scarico dell'olio /
Vidange d'huile / Vaciado de aceite

TR MONTAJ POZİSYONLARI

EN MOUNTING POSITIONS

DE EINBAULAGE

IT PIAZZAMENTO

FR POS. DE MONTAGE

ES POS. DE MONTAJE

AF
AF 301
AF 351
AF 401
AF 501
AF 601
AF 701

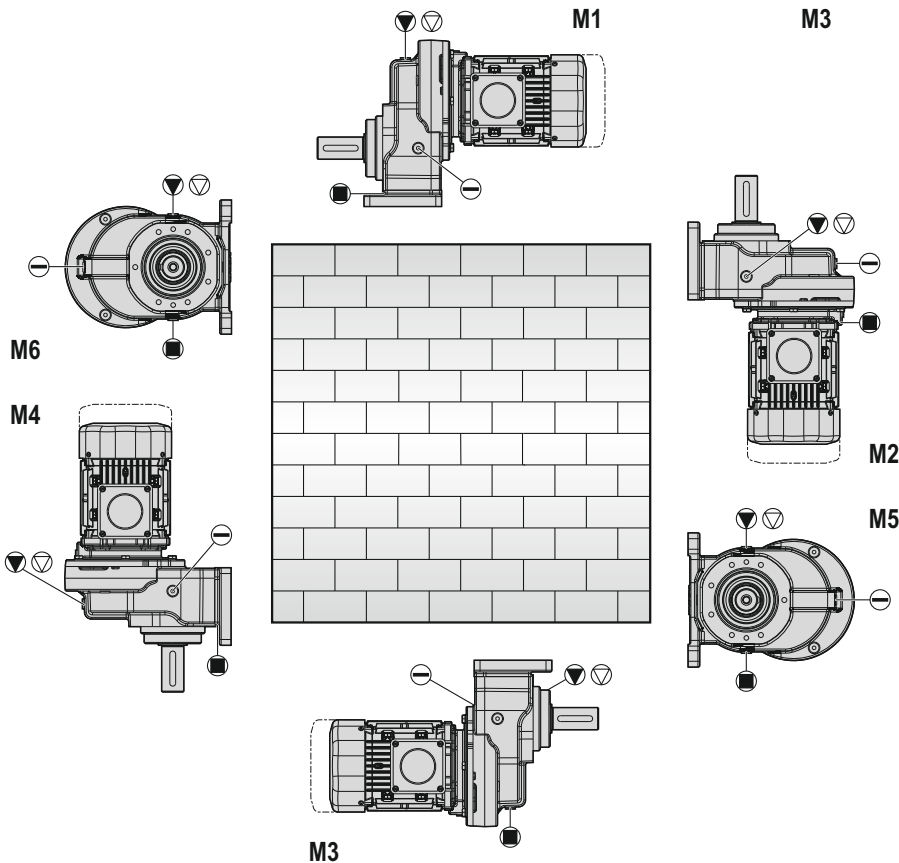
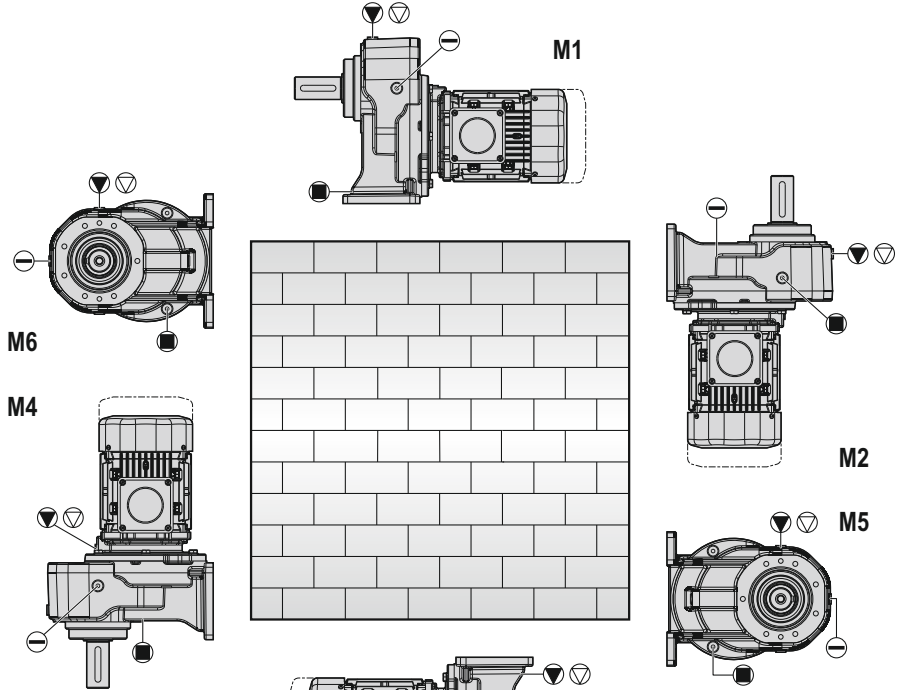

AF - M
AF - M 301
AF - M 351
AF - M 401
AF - M 501
AF - M 601
AF - M 701

⊕ Havalandırma tapası / Vent plug /
Entlüftung / Tappo di sfato /
Évent / Ventilación

⊖ Doldurma tapası / Filling plug /
Einfüllstopfen / Tappo carico /
Bouchon remplissage / Tapón de carga

⊖ Yağ Seviye tapası / Oil level /
Ölstand / Tappo di livello dell'olio /
Niveau d'huile / Nivel de aceite

● Boşaltma tapası / Drain plug /
Ölablass / Tappo di scarico dell'olio /
Vidange d'huile / Vaciado de aceite

TR MONTAJ POZİSYONLARI
IT PIAZZAMENTO

EN MOUNTING POSITIONS
FR POS. DE MONTAGE

DE EINBAULAGE
ES POS. DE MONTAJE

F
F 301
F 351
F 401
F 501
F 601
F 701

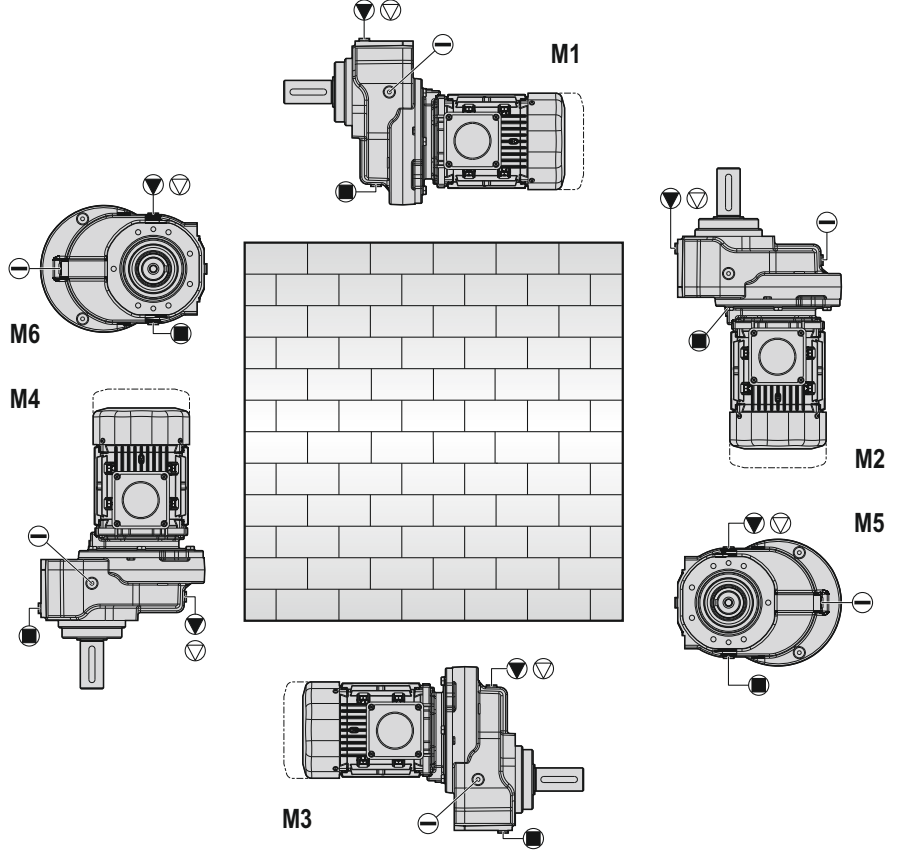

⊕ Havalandırma tapası / Vent plug /
Entlüftung / Tappo di sfciato /
Évent / Ventilación

⊖ Doldurma tapası / Filling plug /
Einfüllstopfen / Tappo carico /
Bouchon remplissage / Tapón de carga

⊖ Yağ Seviye tapası / Oil level /
Ölstand / Tappo di livello dell'olio /
Niveau d'huile / Nivel de aceite

● Boşaltma tapası / Drain plug /
Ölablass / Tappo di scarico dell'olio /
Vidange d'huile / Vaciado de aceite

TR MONTAJ POZİSYONLARI
IT PIAZZAMENTO

EN MOUNTING POSITIONS
FR POS. DE MONTAGE

DE EINBAULAGE
ES POS. DE MONTAJE

A - AF

- AF 252 - 253
- AF 302 - 303
- AF 352 - 353
- AF 402 - 403
- AF 502 - 503
- AF 602 - 603
- AF 702 - 703
- AF 902 - 903

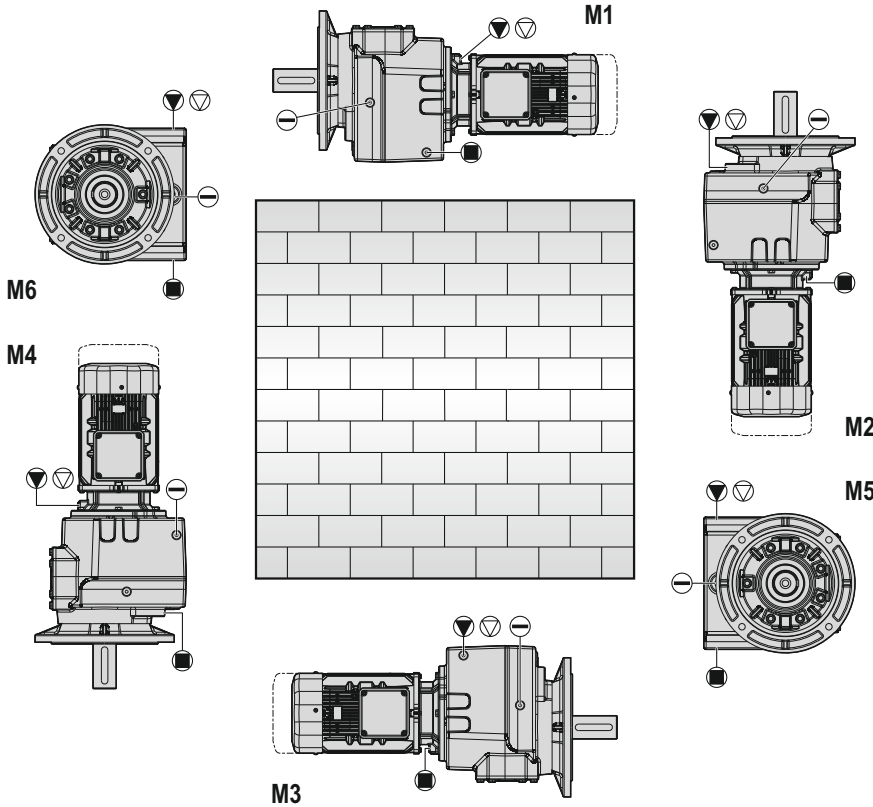
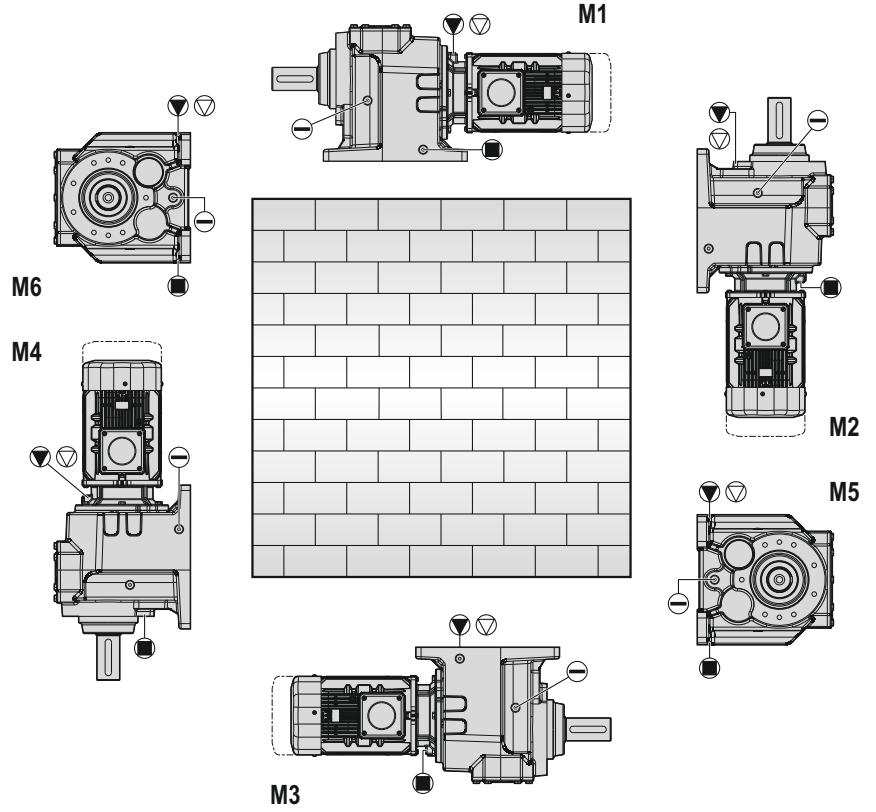

F

- F 252 - 253
- F 302 - 303
- F 352 - 353
- F 402 - 403
- F 502 - 503
- F 602 - 603
- F 702 - 703
- F 902 - 903

○ Havalandırma tapası / Vent plug /
Entlüftung / Tappo di sfiato /
Event / Ventilación

● Doldurma tapası / Filling plug /
Einfüllstopfen / Tappo carico /
Bouchon remplissage / Tapón de carga

○ Yağ Seviye tapası / Oil level /
Ölstand / Tappo di livello dell'olio /
Niveau d'huile / Nivel de aceite

● Boşaltma tapası / Drain plug /
Ölablass / Tappo di scarico dell'olio /
Vidange d'huile / Vaciado de aceite

TR MONTAJ POZİSYONLARI

- Sipariş sırasında özel istekleriniz olacaksa şekilde gösterildiği üzere terminal kutusunun pozisyonunu belirtiniz.
- Aksi belirtilmediği takdirde redüktörlerin klemens kutusu pozisyonu 1 olarak verilir.
- Aksi belirtilmediği takdirde standart pozisyon M1'dir.
- Öngörülen montaj pozisyonları dışında kalan durumlar için teknik servisimize danışınız.

EN MOUNTING POSITIONS

- In the case of specific requirements, when ordering, specify the position of the terminal box as shown in the diagram.
- Unless other wise specified, the gear reducer is supplied with terminal box in position 1.
- Unless specified otherwise, the standard positions are M1.
- For positions not envisaged, it is necessary to call our Technical Service.

DE EINBAULAGE

- Im Falle von Sonderanforderungen ist bei Auftragserteilung die Lage des Klemmkastens gemäß dem Schema genau anzugeben.
- Sofern nichts gegenteiliges angegeben, wird der Schneckengetriebemotor mit Klemmkastenlage 1 geliefert.
- Falls nicht anders angegeben, sind M1 die Standardeinbaulagen.
- Für nicht angegebene Einbaulagen setzen sie sich bitte mit unserem Kundendienst in Verbindung.

IT PIAZZAMENTO

- Nel caso di particolari esigenze specificare in fase di ordine la posizione della morsetteria come da schema.
- Se non diversamente specificato, il gruppo viene fornito con morsetteria in pos.1.
- Se non diversamente specificato le posizioni standard sono M1.
- Per le posizioni di piazzamento non previste to call our Technical Service.

FR POS. DE MONTAGE

- En cas d'exigences particulières, spécifier, lors de la commande, la position du bornier comme d'après le schéma.
- Sauf indications contraires, le réducteur est fourni avec boîte à borne en position 1.
- Si non spécifié, les positions standard sont M1.
- Pour les positions de montage non prévues, contacter notre S.ce technique.

ES POS. DE MONTAJE

- En caso de exigencias particulares, detallar en el pedido, la posición de la caja de bornes según el esquema.
- Si non esta diferentemente especificado, el motorreductor se monta con la caja de bornes en posición 1.
- Si no se especifica el contrario, las posiciones estándar son M1.
- Para las posiciones de montaje no previstas, es necesario ponerse en contacto con nuestro Servicio técnico.

F TERMINAL KUTUSU VE KABLO GİRİŞ YÖNLERİ / POSIZIONE MORSETTIERA E INGRESSO CAVI / KLEMMKASTENLAGE UND KABELFÜHRUNG / POSIZIONE MORSETTIERA E INGRESSO CAVI / POSITION DE LA BOÎTE À BORNES ET DE L'ENTRÉE DE CÂBLE / POSICIÓN DE LA CAJA DE TERMINALES Y ENTRADA DE CABLES

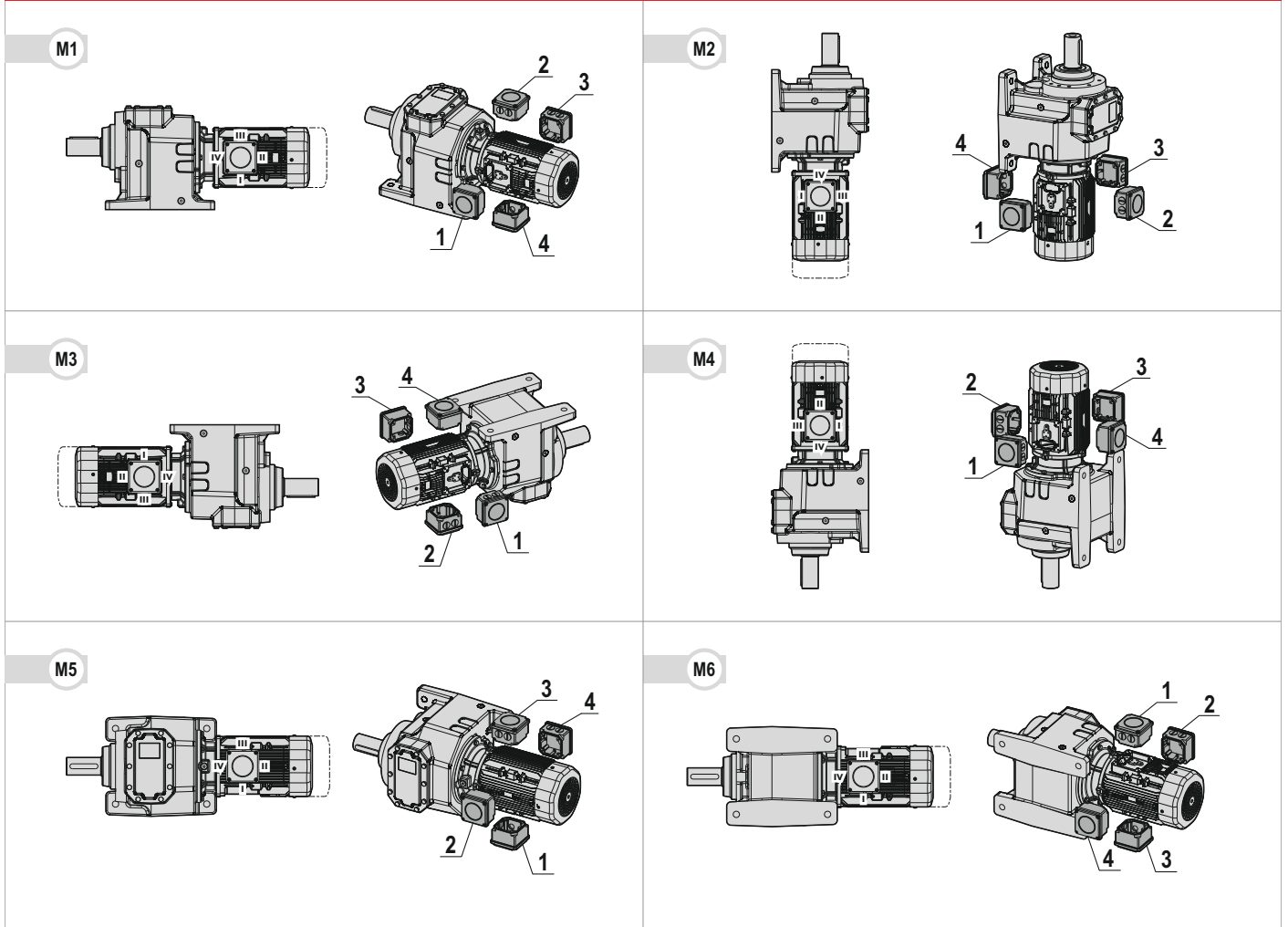

- * 1 - 2 - 3 - 4 : Terminal kutusu yönlerini gösterir.
- * 1 - 2 - 3 - 4 : Shows terminal box position
- * 1 - 2 - 3 - 4 : Zeigt die Position des Klemmkastens an
- * 1 - 2 - 3 - 4 : Mostra la posizione della morsettieria
- * 1 - 2 - 3 - 4 : Affiche la position de la boîte à bornes
- * 1 - 2 - 3 - 4 : Muestra la posición de la caja de terminales

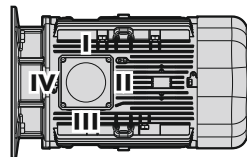

- * I - II - III - IV : Kablo giriş yönlerini gösterir.
- * I - II - III - IV : Shows cable entry position
- * I - II - III - IV : Zeigt die kabeleinführungsposition an
- * I - II - III - IV : Mostra la posizione di ingresso del cavo
- * I - II - III - IV : Indique la position d'entrée du câble
- * I - II - III - IV : Muestra la posición de entrada del cable

TR MONTAJ POZİSYONLARI

- Sipariş sırasında özel istekleriniz olacaksa şekilde gösterildiği üzere terminal kutusunun pozisyonunu belirtiniz.
- Aksi belirtilmediği takdirde redüktörlerin klemens kutusu pozisyonu 1 olarak verilir.
- Aksi belirtilmediği takdirde standart pozisyon M1'dir.
- Öngörülen montaj pozisyonları dışında kalan durumlar için teknik servisimize danışınız.

EN MOUNTING POSITIONS

- In the case of specific requirements, when ordering, specify the position of the terminal box as shown in the diagram.
- Unless other wise specified, the gear reducer is supplied with terminal box in position 1.
- Unless specified otherwise, the standard positions are M1.
- For positions not envisaged, it is necessary to call our Technical Service.

DE EINBAULAGE

- Im Falle von Sonderanforderungen ist bei Auftragserteilung die Lage des Klemmkastens gemäß dem Schema genau anzugeben.
- Sofern nichts gegenteiliges angegeben, wird der Schneckengetriebemotor mit Klemmkastenlage 1 geliefert.
- Falls nicht anders angegeben, sind M1 die Standardeinbaulagen.
- Für nicht angegebene Einbaulagen setzen sie sich bitte mit unserem Kundendienst in Verbindung.

IT PIAZZAMENTO

- Nel caso di particolari esigenze specificare in fase di ordine la posizione della morsetteria come da schema.
- Se non diversamente specificato, il gruppo viene fornito con morsetteria in pos.1.
- Se non diversamente specificato le posizioni standard sono M1.
- Per le posizioni di piazzamento non previste to call our Technical Service.

FR POS. DE MONTAGE

- En cas d'exigences particulières, spécifier, lors de la commande, la position du bornier comme d'après le schéma.
- Sauf indications contraires, le réducteur est fourni avec boîte à borne en position 1.
- Si non spécifié, les positions standard sont M1.
- Pour les positions de montage non prévues, contacter notre S.ce technique.

ES POS. DE MONTAJE

- En caso de exigencias particulares, detallar en el pedido, la posición de la caja de bornes según el esquema.
- Si non esta diferentemente especificado, el motorreductor se monta con la caja de bornes en posición 1.
- Si no se especifica el contrario, las posiciones estándar son M1.
- Para las posiciones de montaje no previstas, es necesario ponerse en contacto con nuestro Servicio técnico.

F TERMINAL KUTUSU VE KABLO GİRİŞ YÖNLERİ / POSIZIONE MORSETTIERA E INGRESSO CAVI /
KLEMMENKASTENLAGE UND KABELFÜHRUNG / POSIZIONE MORSETTIERA E INGRESSO CAVI /
POSITION DE LA BOÎTE À BORNES ET DE L'ENTRÉE DE CÂBLE / POSICIÓN DE LA CAJA DE TERMINALES Y ENTRADA DE CABLES

M1

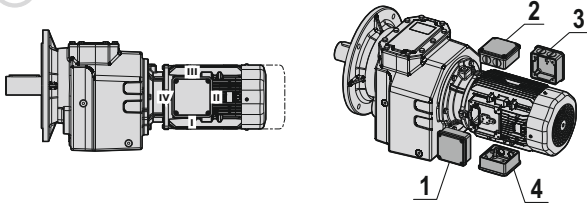

M2

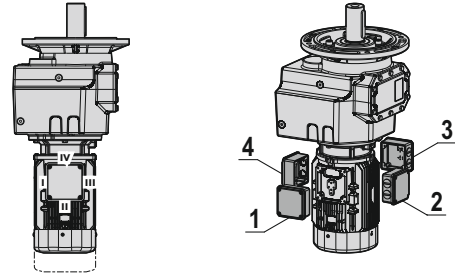

M3

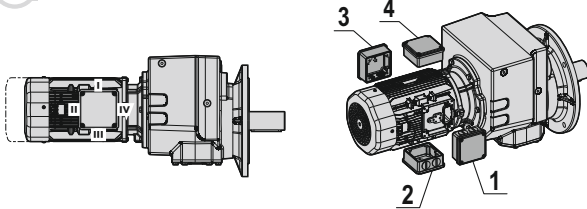

M4

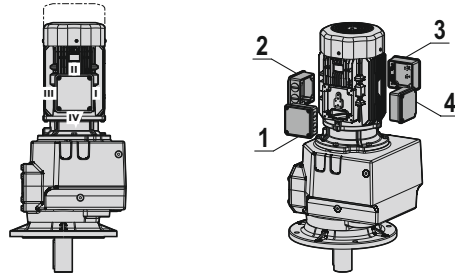

M5

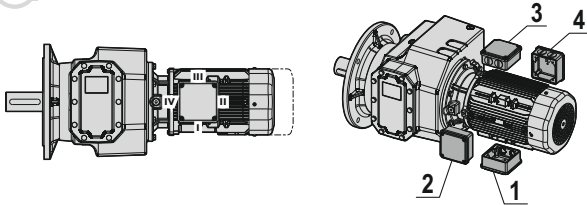

M6

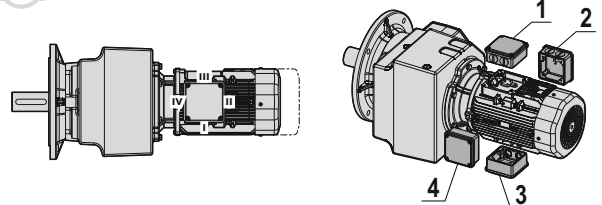

- * 1 - 2 - 3 - 4 : Terminal kutusu yönlerini gösterir.
- * 1 - 2 - 3 - 4 : Shows terminal box position
- * 1 - 2 - 3 - 4 : Zeigt die Position des Klemmkastens an
- * 1 - 2 - 3 - 4 : Mostra la posizione della morsettieria
- * 1 - 2 - 3 - 4 : Affiche la position de la boîte à bornes
- * 1 - 2 - 3 - 4 : Muestra la posición de la caja de terminales

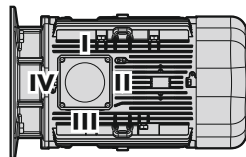

- * I - II - III - IV : Kablo giriş yönlerini gösterir.
- * I - II - III - IV : Shows cable entry position
- * I - II - III - IV : Zeigt die kabeleinführungsposition an
- * I - II - III - IV : Mostra la posizione di ingresso del cavo
- * I - II - III - IV : Indique la position d'entrée du câble
- * I - II - III - IV : Muestra la posición de entrada del cable

TR MONTAJ POZİSYONLARI

- Dikey pozisyonlar için, 10-11. sayfalarda verilen bilgileri kontrol ediniz.
- Herhangi bir seçenek sunulmazsa standart pozisyonumuz M1'dir.
- Farklı pozisyon belirtildiği takdirde, Teknik Servisimize başvurmanız gerekmektedir.

EN MOUNTING POSITIONS

- For vertical positions, check with pages 10-11.
- Unless specified otherwise, the standard positions are M1.
- For positions not envisaged, it is necessary to call our Technical Service.

DE EINBAULAGE

- Für die vertikalen Einbautagen siehe seite 10-11.
- Falls nicht anders angegeben, sind M1 die Standardeinbautagen.
- Für nicht angegebene einbautagen setzen sie sich bitte mit unserem Kundendienst in verbindung.

IT PIAZZAMENTO

- Per le posizioni di piazzamento verticali verificare quanto detto a pag. 10-11.
- Se non diversamente specificato le posizioni standard sono M1.
- Per le posizioni di piazzamento non previste occorre rivolgersi al ns. Servizio tecnico.

FR POS. DE MONTAGE

- Pour les positions de montage verticales, voir pages 10 et 11.
- Si non spécifié, les positions standard sont M1.
- Pour les positions de montage non prévues, contacter notre S.ce technique.

ES POS. DE MONTAJE

- Para las posiciones de montaje verticales, ver las páginas 10-11.
- Si non se especifica el contrario, las posiciones estándar son M1.
- Para las posiciones demontajenoprevistas, es necesario ponerse en contacto con nuestro Servicio técnico.

A301...701
A202...902
A253...903

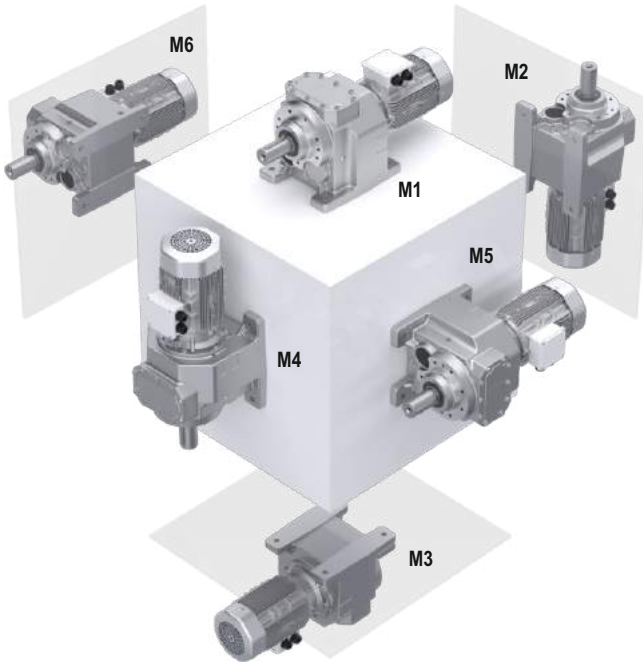

F301...701
F202...902
F253...903

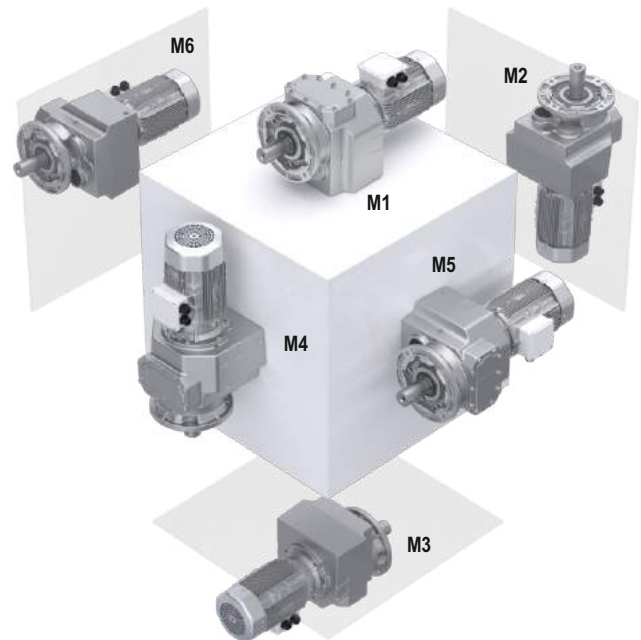

TR A/F MODÜLER SİSTEM

EN MODULAR SYSTEM OF A/F

DE A/F MODULARES SYSTEM

IT SISTEMA MODULARE A/F

FR SYSTÈME MODULAIRE A/F

ES SISTEMA MODULAR A/F

MOTOR

- Akuple elektrik motor versiyonu.
- Compact electric motor versions.
- Ausführungen mit Kompaktelektromotoren.
- Compact electric motor versions.
- Versioni con motore elettrico compatto.
- Version avec moteur électrique compact.
- Versión motorreductor compacto.

PAM

- PAM bağlantılı versiyon.
- Fitted for motor coupling version (PAM).
- Ausführungen zum Anbau von PAM - Motoren.
- Versione con predisposizione per attacco motore PAM.
- Version avec prédisposition pour moteur PAM.
- Versión motorreductor (PAM).

IEC

- Kaplinli motor bağlantısı.
- Fitted for motor mounting with flexible coupling.
- Die Verbindung Motor Getriebe erfolgt über Kupplung.
- Predisposto per attacco motore con giunto.
- Prédisposé pour montage moteur avec joint.
- Predisposto para montaje motor con acoplamiento.

W

- Serbest giriş milli versiyon.
- Input shaft versions.
- Ausführungen mit Antriebsvollwelle.
- Versioni con albero maschio in ingresso.
- Version avec arbre en entrée.
- Versión con eje macho de entrada.

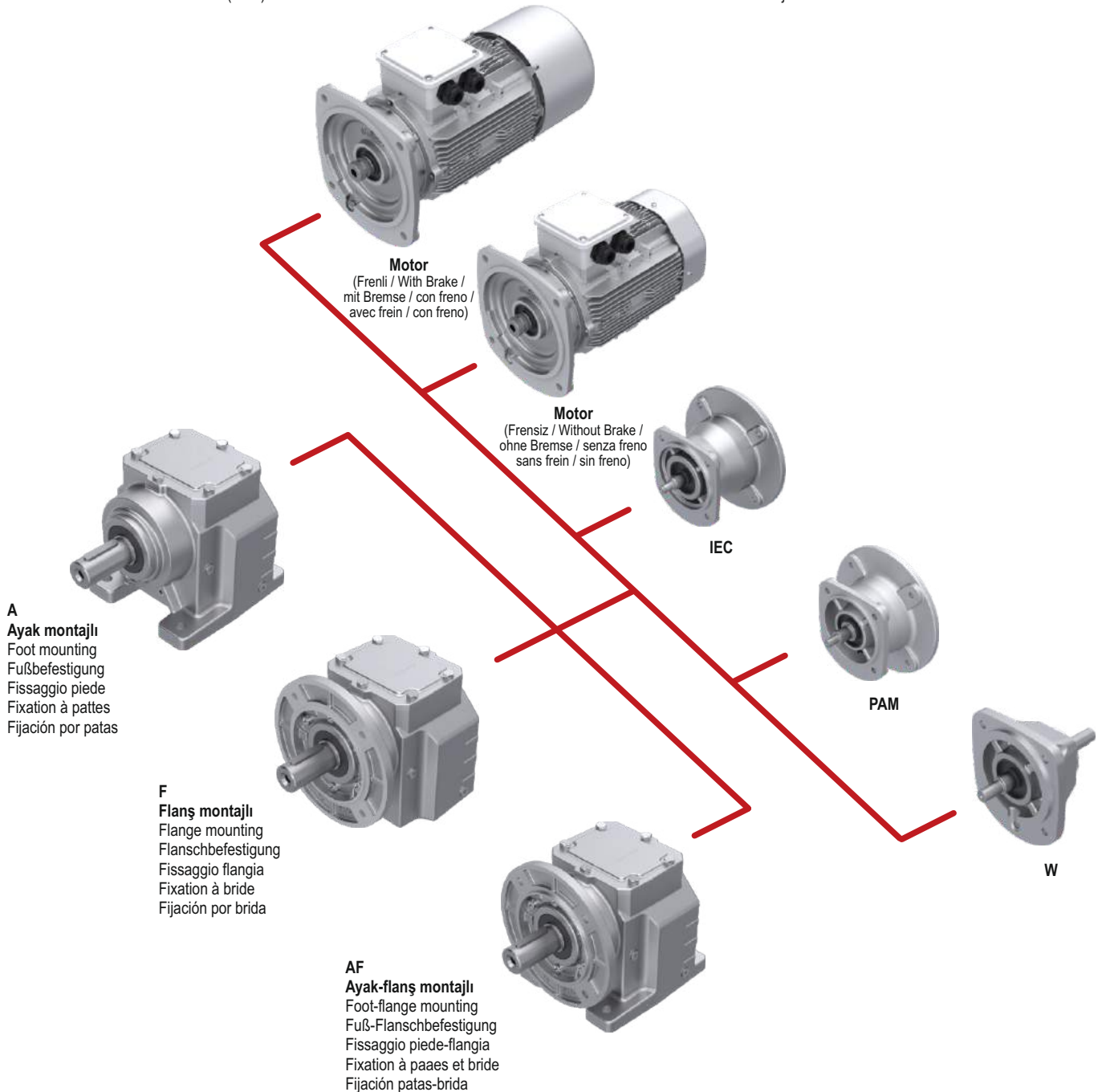

TR	ÜRÜNLERİMİZ	EN	PRODUCTS	DE	PRODUKTE
IT	PRODOTTI	FR	PRODUITS	ES	PRODUCTOS

A... / MOTOR

Ayak montajlı / Foot mounting / Fußbefestigung /
Fissaggio piede / Fixation à pattes / Fijación por patas

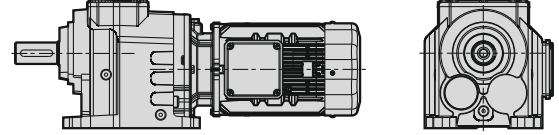

A... / PAM

Ayak montajlı / Foot mounting / Fußbefestigung /
Fissaggio piede / Fixation à pattes / Fijación por patas

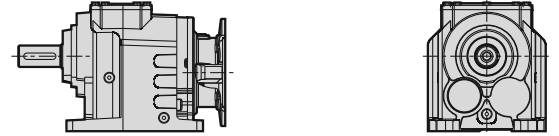

A... / W

Ayak montajlı / Foot mounting / Fußbefestigung /
Fissaggio piede / Fixation à pattes / Fijación por patas

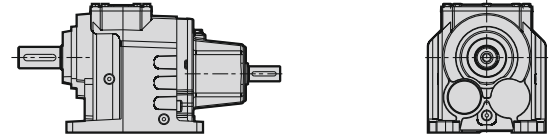

F... / MOTOR

Flanş montajlı / Flange mounting / Flanschbefestigung /
Fissaggio flangia / Fixation à bride / Fijación por brida

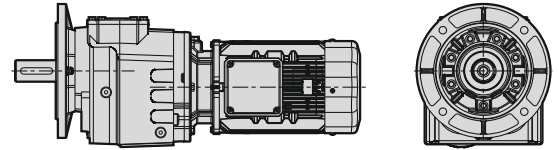

F... / PAM

Flanş montajlı / Flange mounting / Flanschbefestigung /
Fissaggio flangia / Fixation à bride / Fijación por brida

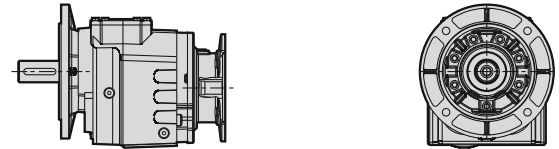

F... / W

Flanş montajlı / Flange mounting / Flanschbefestigung /
Fissaggio flangia / Fixation à bride / Fijación por brida

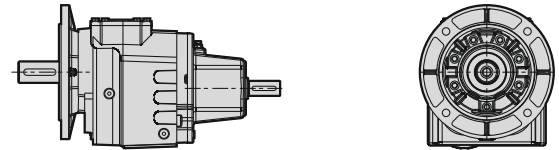

AF... / MOTOR

Ayak-flanş montajlı / Foot-flange mounting / Fuß-Flanschbefestigung /
Fissaggio piede-flangia / Fixation à paaes et bride / Fijación patas-brida

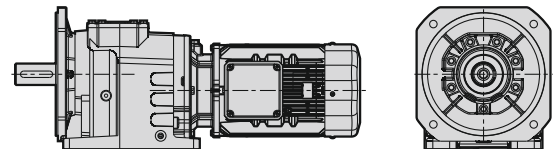

AF... / PAM

Ayak-flanş montajlı / Foot-flange mounting / Fuß-Flanschbefestigung /
Fissaggio piede-flangia / Fixation à paaes et bride / Fijación patas-brida

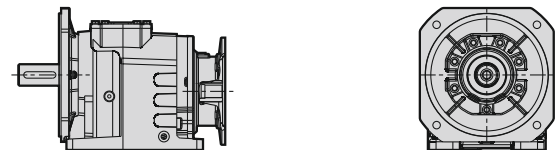

AF... / W

Ayak-flanş montajlı / Foot-flange mounting / Fuß-Flanschbefestigung /
Fissaggio piede-flangia / Fixation à paaes et bride / Fijación patas-brida

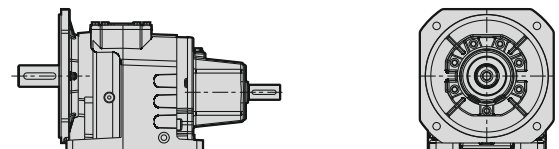

TR REDÜKTÖR SEÇİM FORMU

1- REDÜKTÖR

Kullanılacak Sektör:

Uygulama Yeri:

Günlük Çalışma Saati:

<4 [] 4-8 [] 8-16 [] >16 []

Saatteki Dur-Kalk Sayısı:

0-50 [] 50-100 [] 100-200 [] 200-300 []
300-500 [] 500-700 [] 700-1000 [] >1000 []

Giriş Seçeneği: Motorlu [] Motorsuz []

Talep Edilen Motor Gücü:kW

Talep Edilen Motor Devri:d/dak

Talep Edilen Çıkış Devri:d/dak

2 - GİRİŞ - ÇIKIŞ

Tahrik Tipi:

AC Motor [] AC Motor + Invertör [] Servo Motor []
Hidro Motor [] Serbest Giriş Mili [] Diğer []

Motor Bağlantı Flanşı (Elektirik Motorlu ise):

Akuple [] IEC B5 [] PAM B5 []
PAM B14 [] NEMA []

Giriş Mili Özelliği (Serbest Giriş Milli ise):

Kamalı [] Diğer.....

Giriş Mili Tahrik Tipi (Serbest Giriş Milli ise):

Elastik Kaplin [] Hidrolik Kaplin [] Küçük Hızlarda Zincir Dişli [] Düz Dişli []
Triger Kayış [] V Kayış [] Gergirme Makaralı Kayış []

Giriş Mili Yük Durumu (Serbest Giriş Milli ise):

Radyal yük.....N
Eksenel Yük.....N / Çeki [] Bası []

Çıkış Mili Özelliği (Serbest Giriş Milli ise):

Mil Çıkışlı [] Delik Milli [] Konik Sıkırtma Şaftlı []
Diğer.....

Çıkış Mili Tahrik Tipi:

Direkt [] Elastik Kaplin [] Hidrolik Kaplin [] Küçük Hızlarda Zincir Dişli []
Düz Dişli [] Triger Kayış [] V Kayış [] Gerdirme Makaralı Kayış []

Çıkış Mili Yük Durumu :

Radyal yük.....N
Eksenel Yük.....N / Çeki [] Bası []

3 - MONTAJ

Montaj Pozisyonu:

M1 [] M2 [] M3 [] M4 [] M5 [] M6 []

Kilit Durumu:

Var [] Yok []

Deniz Seviyesinden Yükseklik:

0-1000 [] 1000-2000 [] 2000-3000 [] 3000-4000 [] 4000-5000 []

Ortam Durumu:

Açık (1,25 m/sn) [] Kapalı (4 m/sn) []

Ortam Şartları:

Normal [] Tozlu [] Nemli [] Kuru []

Diğer.....

Ortam Sıcaklığı:.....°C

4 - MOTOR

Elektiriksel Değer:

Voltaj.....V

Frekans.....Hz

Koruma Sınıfı:

IP55 [] IP65 [] Exproof []

Diğer IP.....

Terminal Kutusu Yönü:

1 [] 2 [] 3 [] 4 []

Termistör:

Var [] Yok []

Fren Durumu:

Var [] Yok []

Atex:

2G [] 2D [] Yok []

Diğer.....

Diğer Notlar:

.....
.....
.....
.....
.....
.....
.....
.....
.....
.....

Lütfen doğru redüktör seçimi yapabilmek için gerekli bilgileri doldurunuz!

EN GEARBOX SELECTION FORM

1- GEAR UNIT

Sector for which will be used:

Application area:.....

Daily working hour:
 <4 [] 4-8 [] 8-16 [] >16 []

Revolution per hours:
 0-50 [] 50-100 [] 100-200 [] 200-300 []
 300-500 [] 500-700 [] 700-1000 [] >1000 []

Input option: With motor [] Without motor []

Requested Motor Power:.....kW

Requested Motor Rotation:.....min⁻¹

Requested Output Rotation:.....min⁻¹

2 - INPUT - OUTPUT

Drive type:
 AC Motor [] AC Motor + Invertor [] Servo Motor []
 Hydromotor [] Free Input Shaft [] Diđer []

Motor Connection Flange (With Electric Motor):
 Direct [] IEC B5 [] PAM B5 []
 PAM B14 [] NEMA []

Property of Input Shaft (with free input shaft):
 With Key [] Other.....

Driving type of Input Shaft(with free input shaft):
 Elastic Coupling [] Hydraulic Coupling [] For Chain Drive With Low Speed []
 For Spur Gear [] For Trigger Belt [] For V belt [] Flat Belt With Spanning Pulley []

Input Shaft Load case (with free input shaft):
 Radial Load.....N
 Axial Load.....N / Draw [] Impression []

Property of Output Shaft (with free input shaft):
 Solid Shaft [] Hollow shaft [] Shaft for Shrink Disc []
 Other.....

Output Shaft Drive type:
 Direct [] Elastic Coupling [] Hydraulic Coupling [] Chain Drive With Low Speed []
 Spur Gear [] Trigger Belt [] V Belt [] Flat Belt With Spanning Pulley []

Output Shaft Load case:
 Radial Load.....N
 Axial Load.....N / Draw [] Impression []

3 - MOUNTING

Mounting Position:
 M1 [] M2 [] M3 [] M4 [] M5 [] M6 []

Backstop Situation:
 Yes [] No []

Altitude above sea level:
 0-1000 [] 1000-2000 [] 2000-3000 [] 3000-4000 [] 4000-5000 []

Ambient Situation:
 Open (1,25 m/sn) [] Close (4 m/sn) []

Ambient Conditions:
 Normal [] Dusty [] Humid [] Dry []
 Other.....

Ambient Temperature :.....°C

4 - MOTOR

Elektrical Value:
 Voltage.....V
 Frequency.....Hz

Protection Class :
 IP55 [] IP65 [] Exproof []
 Other IP.....

Terminal Box Position:
 1 [] 2 [] 3 [] 4 []

Thermistor :
 Yes [] No []

Brake Situation:
 Yes [] No []

Atex:
 2G [] 2D [] Yok []
 Other.....

Other Notes:

Please give required informations for selecting correct reducer!

DE FORMULAR FÜR GETRIEBEAUSWAHL

1- GETRIEBE

Sektor :

Anwendungsbereich:.....

Betriebsstunden/Tag:
 <4 [] 4-8 [] 8-16 [] >16 []

Anlauf pro Stunde:
 0-50 [] 50-100 [] 100-200 [] 200-300 []
 300-500 [] 500-700 [] 700-1000 [] >1000 []

Antriebsoption: mit Motor [] ohne Motor []

Geforderte Motorleistung:.....kW

Angeforderte Motordrehzahl:.....min⁻¹

Angeforderter Abtriebsdrehzahl:.....min⁻¹

2 - ANTRIEB - ABTRIEB

Antriebstyp:
 Wechselstrommotor [] Wechselstrommotor + Wechselrichter [] Servomotor []
 Hydromotor [] Freie Antriebswelle [] Sonstiges []

Motoranschlussflansch (bei Elektromotor):
 Gekoppelt [] IEC B5 [] PAM B5 []
 PAM B14 [] NEMA []

Antriebswelleneigenschaft (bei freier Antriebswelle):
 mit Passfeder [] Sonstiges.....

Antriebsart der Antriebswelle (bei freier Antriebswelle):
 Elastische Kupplung [] Hydraulische Kupplung [] Kettenrad bei kleinen Drehzahlen []
 Stirnrad [] Zahnriemen [] Keilriemen [] Spannrollenriemen []

Belastungsart der Antriebswelle (bei freier Antriebswelle):
 Radiale BelastungN
 Axiale Belastung.....N / Zug [] Druck []

Abtriebswelleneigenschaft (bei freier Antriebswelle):
 Vollwelle [] Hohlwelle [] Welle mit Schrumpfscheibe []
 Sonstiges.....

Antriebsart der Abtriebswelle:
 Direkt [] Elastische Kupplung [] Hydraulische Kupplung [] Stirnrad [] Keilriemen []
 Kettenrad bei kleinen Drehzahlen [] Zahnriemen [] Spannrollenriemen []

Belastungsart der Abtriebswelle:
 Radiale BelastungN
 Axiale Belastung.....N / Zug [] Druck []

3 - MONTAGE

Einbaulage:
 M1 [] M2 [] M3 [] M4 [] M5 [] M6 []

Rücklaufsperre:
 Ja [] Nein []

Höhe über dem Meeresspiegel:
 0-1000 [] 1000-2000 [] 2000-3000 [] 3000-4000 [] 4000-5000 []

Umgebungsbedingungen:
 Ein (1,25 m/sn) [] Aus (4 m/sn) []

Umweltbedingungen:
 Normal [] staubig [] feucht [] trocken []
 Sonstiges.....

Umgebungstemperatur:.....°C

4 - MOTOR

Elektrischer Wert:
 Stromspannung.....V
 Frequenz.....Hz

Schutzklasse:
 IP55 [] IP65 [] Ex-geschützt []
 Andere IP.....

Ausrichtung des Klemmenkastens:
 1 [] 2 [] 3 [] 4 []

Thermistor:
 Ja [] Nein []

Bremse:
 Ja [] Nein []

Atex:
 2G [] 2D [] Nein []
 Sonstiges.....

Andere Notizen:

Bitte geben Sie die notwendigen Informationen an, um das richtige Getriebe auswählen zu können!

IT MODULO DI SELEZIONE RIDUTTORE

1- RIDUTTORE

Settore per il quale verrà utilizzato:

Area di applicazione:.....

orario di lavoro giornaliero:

<4 [] 4-8 [] 8-16 [] >16 []

Rivoluzione all'ora:

0-50 [] 50-100 [] 100-200 [] 200-300 []
300-500 [] 500-700 [] 700-1000 [] >1000 []

Opzione di input: con motore [] Senza motore []

Potenza motore richiesta:.....kW

Rotazione motore richiesta:.....min⁻¹

Rotazione uscita richiesta:.....min⁻¹

2 - INGRESSO-USCITA

Tipo di guida:

AC Motore [] AC Motore + invertitore [] Servomotore []
Idromotore [] Albero di ingresso libero [] Altro []

Flangia di collegamento del motore (con motore elettrico):

Diretto [] IEC B5 [] PAM B5 []
PAM B14 [] NEMA []

Proprietà dell'albero di ingresso (con albero di ingresso libero):

Con Chiave [] Altro.....

Tipo di guida dell'albero di ingresso (con albero di ingresso libero):

Accoppiamento elastico [] Accoppiamento idraulico []
Per trasmissione a catena a bassa velocità [] Per ingranaggio cilindrico []
Per cinghia a scatto [] Per cinghia trapezoidale [] Cinghia piatta con puleggia []

Caso di carico dell'albero di ingresso (con albero di ingresso libero):

Carico radiale.....N
Carico assiale.....N / Disegno [] Impressione []

Proprietà dell'albero di uscita (con albero di ingresso libero):

Albero solido [] Albero cavo [] Albero per calettatore []
Altro.....

Tipo di trasmissione dell'albero di uscita:

Diretto [] Accoppiamento elastico [] Accoppiamento idraulico []
Per trasmissione a catena a bassa velocità [] Per ingranaggio cilindrico []
Per cinghia a scatto [] Per cinghia trapezoidale [] Cinghia piatta con puleggia []

Caso di carico dell'albero di uscita:

Carico radiale.....N
Carico assiale.....N / Disegno [] Impressione []

3 - MONTAGGIO

Posizione di montaggio:

M1 [] M2 [] M3 [] M4 [] M5 [] M6 []

Stato di blocco:

C'è [] No []

Altitudine sul livello del mare:

0-1000 [] 1000-2000 [] 2000-3000 [] 3000-4000 [] 4000-5000 []

Situazione ambientale:

Aperto (1,25 m/sn) [] Chiusa(4 m/sn) []

Condizioni ambientali:

Normale [] Polverosa [] Umido [] Asciutto []

Altro.....

Temperatura ambiente:.....°C

4 - MOTORE

Valore elettrico:

Voltaggio.....V
Frequenza.....Hz

Classe di protezione:

IP55 [] IP65 [] Exproof []
Altro IP.....

Posizione della morsettiera:

1 [] 2 [] 3 [] 4 []

Termistore :

Si [] No []

Situazione del freno:

Si [] No []

Atex:

2G [] 2D [] Yok []

Altro.....

Altre note:

.....
.....
.....
.....
.....
.....
.....
.....

Si prega di fornire le informazioni necessarie per selezionare il riduttore corretto!

FR FORMULAIRE DE SÉLECTION DE RÉDUCTEURS

1- RÉDUCTEUR

Secteur pour lequel sera utilisé:

Domaine d'application:

heures de travail quotidiennes:

<4 [] 4-8 [] 8-16 [] >16 []

Révolution par heure:

0-50 [] 50-100 [] 100-200 [] 200-300 []
300-500 [] 500-700 [] 700-1000 [] >1000 []

Options d'entrée: Avec moteur [] Sans moteur []

Puissance moteur demandée:kW

Régime moteur demandé:min⁻¹

Rotation de sortie demandée:min⁻¹

2 - ENTRÉE-SORTIE

Type de lecteur:

AC Moteur [] AC Moteur + onduleur [] Servomoteur []
Hydromoteur [] Arbre d'entrée libre [] Autre []

Bride de connexion du moteur (avec moteur électrique):

Direct [] IEC B5 [] PAM B5 []
PAM B14 [] NEMA []

Propriété de l'arbre d'entrée (avec arbre d'entrée libre):

Avec clé [] Autre:

Type d'entraînement de l'arbre d'entrée (avec arbre d'entrée libre):

Accouplement élastique [] Accouplement hydraulique [] Pour entraînement par chaîne à basse vitesse [] Pour engrenage droit [] Pour ceinture de déclenchement []
Pour courroie trapézoïdale [] Courroie plate avec poulie couvrante []

Cas de charge de l'arbre d'entrée (avec arbre d'entrée libre):

Charge radiale.....N
Charge axiale.....N / dessiner [] Impression []

Propriété de l'arbre de sortie (avec arbre d'entrée libre):

Arbre plein [] Creux arbre [] Arbre pour disque rétractable []
Autre:

Type d'entraînement de l'arbre de sortie:

Direct [] Accouplement élastique [] Accouplement hydraulique [] Pour entraînement par chaîne à basse vitesse [] Pour engrenage droit [] Pour ceinture de déclenchement []
Pour courroie trapézoïdale [] Courroie plate avec poulie couvrante []

Cas de charge de l'arbre de sortie:

Charge radiale.....N
Charge axiale.....N / dessiner [] Impression []

3 - MONTAGE

Position de montage:

M1 [] M2 [] M3 [] M4 [] M5 [] M6 []

Statut de verrouillage:

Oui [] Non []

Altitude au-dessus du niveau de la mer:

0-1000 [] 1000-2000 [] 2000-3000 [] 3000-4000 [] 4000-5000 []

Situation ambiante:

Ouvert (1,25 m/sn) [] Ferme (4 m/sn) []

Conditions ambiantes:

Normal [] Poussiéreux [] Humide [] Sec []

Autre:

Température ambiante:°C

4 - MOTEUR

Valeur électrique:

Voltage.....V
Fréquence.....Hz

Classe de protection:

IP55 [] IP65 [] Exproof []
Autre IP:

Emplacement de la boîte à bornes:

1 [] 2 [] 3 [] 4 []

Thermistance :

Oui [] Non []

Situation de freinage:

Oui [] Non []

Atex:

2G [] 2D [] Yok []

Autre:

Autres notes:

.....
.....
.....
.....
.....
.....
.....
.....

Veuillez fournir les informations requises pour sélectionner le bon réducteur!

ES FORMULARIO DE SELECCIÓN DEL REDUCTOR

1- REDUCTOR

Sector para el que se utilizará:

Área de aplicación:.....

Horas de trabajo diarias:

<4 [] 4-8 [] 8-16 [] >16 []

Revolución por hora:

0-50 [] 50-100 [] 100-200 [] 200-300 []
300-500 [] 500-700 [] 700-1000 [] >1000 []

Opción de entrada: Con motor [] Sin motor []

Potencia del motor solicitada:.....kW

Rotación de motor solicitada:.....min⁻¹

Retorno de salida deseado:.....min⁻¹

2 - ENTRADA-SALIDA

Tipo de unidad:

AC Motor [] AC Motor + Inversor [] Servo Motor []
Hydromotor [] Eje de entrada libre [] Otro []

Brida de conexión del motor (con motor eléctrico):

Direct [] IEC B5 [] PAM B5 []
PAM B14 [] NEMA []

Propiedad del eje de entrada (con eje de entrada libre):

Con llave [] Otro.....

Tipo de conducción del eje de entrada (con eje de entrada libre):

Acoplamiento elástico [] Acoplamiento hidráulico [] Para transmisión por cadena con baja velocidad [] Para engranaje recto [] Para cinturón de gatillo []
Para correa trapezoidal [] Correa plana con polea extensible []

Eje de entrada Caso de carga (con eje de entrada libre):

Carga Radial.....N
Carga axial.....N / Dibujar [] Impresión []

Propiedad del eje de salida (con eje de entrada libre):

Eje sólido [] eje hueco [] Eje para disco retráctil []
Otro.....

Tipo de transmisión del eje de salida:

Directo [] Acoplamiento elástico [] Acoplamiento hidráulico [] Para transmisión por cadena con baja velocidad [] Para engranaje recto [] Para cinturón de gatillo []
Para correa trapezoidal [] Correa plan con polea extensible []

Caso de carga del eje de salida:

Carga Radial.....N
Carga axial.....N / Dibujar [] Impresión []

3 - MONTAJE

Posición de montaje:

M1 [] M2 [] M3 [] M4 [] M5 [] M6 []

Situación de respaldo:

Sí [] No []

Altitud sobre el nivel del mar:

0-1000 [] 1000-2000 [] 2000-3000 [] 3000-4000 [] 4000-5000 []

Situación ambiental:

abierto (1,25 m/sn) [] Cerca (4 m/sn) []

Condiciones ambientales:

Normal [] Polvoriento [] Húmedo [] Seco []

Otro.....

Temperatura ambiente:.....°C

4 - MOTOR

Valor eléctrico:

Voltaje.....V
Frecuencia.....Hz

Clase de protección:

IP55 [] IP65 [] Exproof []
Other IP.....

Posición de la caja de terminales:

1 [] 2 [] 3 [] 4 []

Termistor:

Sí [] No []

Situación del freno:

Sí [] No []

Atex:

2G [] 2D [] Yok []

Otro.....

Otras notas:

.....
.....
.....
.....
.....
.....
.....

Proporcionar la información necesaria para elegir el reductor adecuado!

TR SİPARİŞ ÖRNEĞİ
IT ESEMPIO DI ORDINAZIONE

EN EXAMPLE FOR ORDERING
FR EXEMPLE DE COMMANDE

DE BEISPIEL BESTELLBESCHREIBUNG
ES EJEMPLO ORDEN DE COMPRA

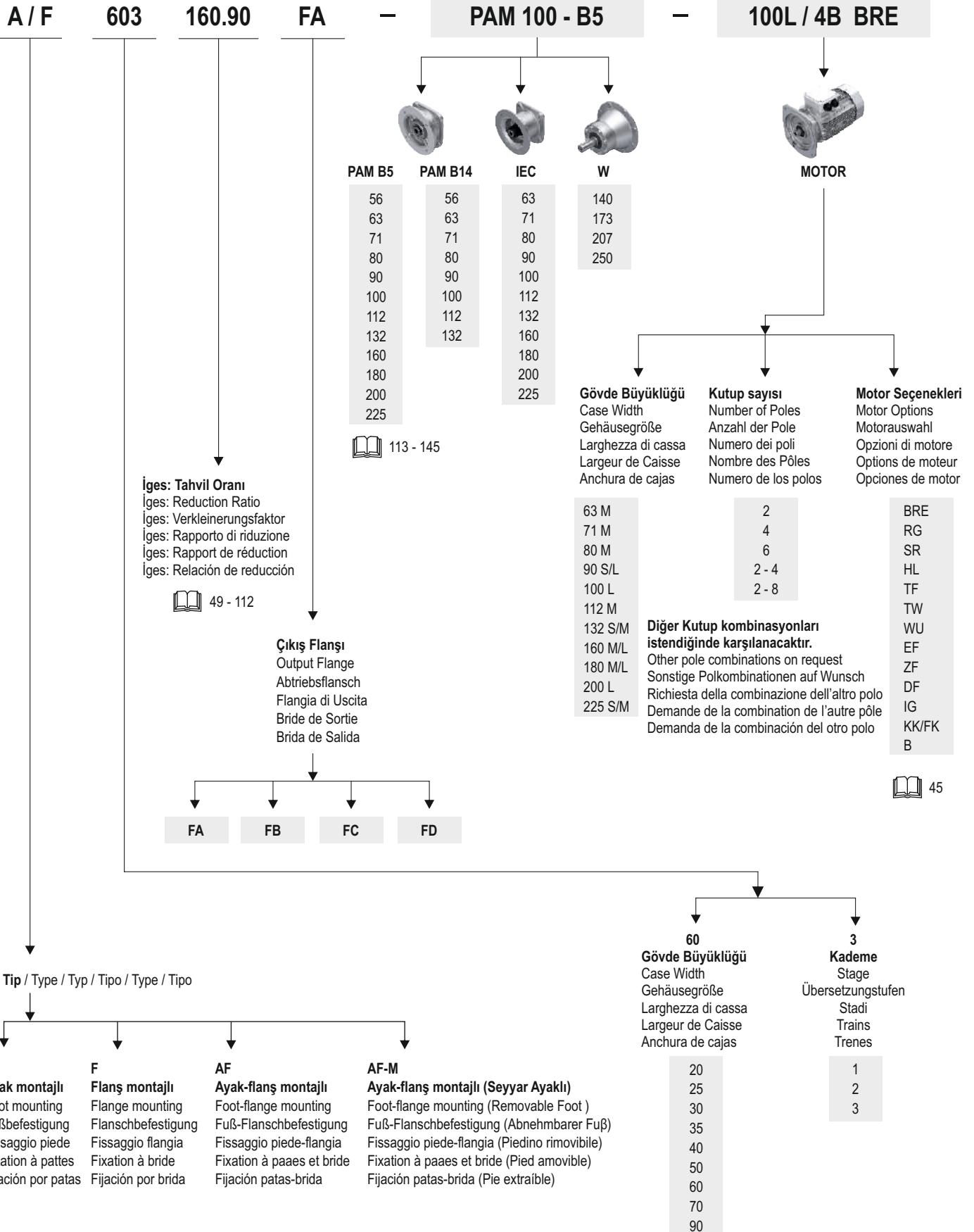

TR	TASARIM	EN	DESIGNATION	DE	BEZEICHNUNG
IT	DESIGNAZIONE	FR	DÉSIGNATION	ES	DESIGNACIÓN

A / F	Aküple motorlu helisel dişli redüktör Compact geared motor with helical gears (supplied complete with motor) Kompakter Stirnradgetriebemotor (mit Motor geliefert) Motoriduttore ad ingranaggi cilindrici compatto (fornito completo di motore) Motoréducteur à engrenages cylindriques compact (livré avec moteur) Motorreductor de engranajes cilíndricos compacto (motor y reductor compacto)		
252	Boyut 25, 2 kademeli - Gri demir döküm serisi Size 25, 2 reduction stages, cast iron series Baugröße 25 - 2 Übersetzungsstufen - Ausführung in Grauguss Grandezza 25, 2 stadi di riduzione, serie in ghisa Grandeur 25, 2 trains d'engrenages, série en fonte Tamaño 25, 2 trenes de engranajes, gama de fundición		
FA - FB FC - FD	Çıkış flanşı Output flange Abtriebsflansch Flangia di uscita Bride de sortie Brida de salida		
44.7	Tahvil oranı Reduction ratio Übersetzungsverhältnis Rapporto di riduzione Rapport de réduction Relación de reducción		
M1	Montaj Pozisyonu Mounting position Einbaulage Posizione di piazzamento Position de montage Posición de montaje		
Giriş ölçüleri / Input dimensions / Abmessungen antriebsseitig / Dimensioni di entrata / Dimensions d'entrée / Dimensiones de entrada			
PAM	Motor bağlantısı için Fitted for motor coupling Für motoranbau vorbereitet Predisposto per attacco motore Prêdisposé pour montage moteur standard Predispuerto para montaje motor		
160	Motor flanş çapı Motor flange diameter Motorflansch - Durchmesser Diametro flangia motore Diamètre bride moteur Diámetro brida motor	14	Motor giriş şaftı çapı Drive - shaft diameter Motorwellen - Durchmesser Diametro albero motore Diamètre arbre moteur Diámetro eje motor
Çıkış ölçüleri / Output dimensions / Abmessungen abtriebsseitig / Dimensioni di uscita / Dimensions de sortie / Dimensiones de salida			
200	Çıkış flanş çapı Output flange diameter Durchmesser Abtriebsflansch Diametro flangia uscita Diamètre de la bride de sortie Diámetro brida de salida	25	Çıkış mili çapı Output shaft diameter Durchmesser abtriebswelle Diametro albero uscita Diamètre de l'arbre de sortie Diámetro eje de salida

TR	KULLANILAN TERİMLER	EN	NOMENCLATURE	DE	NOMENKLATUR
IT	NOMENCLATURA	FR	NOMENCLATURE	ES	NOMENCLATURA

<p>Giriş Aksamları Input Options Eingabeoptionen opzioni di ingresso options d'entrée opciones de entrada</p>	<p>W = Motorsuz girişli redüktörler için aksam / Input shaft versions / Ausführungen mit antriebsvollwelle / Versioni con albero maschio in ingresso / Version avec arbre en entrée / Versión con eje macho de entrada.</p> <p>IEC = DIN 42677' ye göre standart motorlar için aksamlar / Fitted for motor mounting with flexible coupling. Die Verbindung Motor Getriebe erfolgt über Kupplung. / Predisposto per attacco motore con giunto. Prédisposé pour montage moteur avec joint. / Predisposto para montaje motor con acoplamiento.</p> <p>PAM = Motor bağlantısı için / Fitted for motor coupling / Für motoranbau vorbereitet / Predisposto per attacco motore Prédisposé pour montage moteur standard / Predisposto para montaje motor</p> <p>T = Turbo kaplin / Turbo coupling / Turbokupplung / Turbogunto / Coupleur hydraulique / Turboacoplador</p>
<p>Motor Motor Motor Motore Moteur Motor</p>	<p>Üç fazlı motor, Motor boyutu 63 - 225 / Three phase motor Motor size 63 - 225 / Drehstrommotor Motorgröße 63 - 225 / Motori trifase, Grandezza 63 - 225 / Motore thriphasé, taille moteur 63 - 225 / Motores trifásicos, Tamaño de carcasas 63 - 225</p>
<p>Kutup Numarası Number of Poles Anzahl der Pole Numero dei poli Nombre des Pôles Numero de los polos</p>	<p>2 = 2 Kutuplu / 2 Poles / 2 Pole / 2 Pôles / 2 Polos</p> <p>4 = 4 Kutuplu / 4 Poles / 4 Pole / 4 Pôles / 4 Polos</p> <p>6 = 6 Kutuplu / 6 Poles / 6 Pole / 6 Pôles / 6 Polos</p> <p>Diğer Kutup kombinasyonları istendiğinde karşılanacaktır. Other pole combinations on request / Sonstige Polkombinationen auf Wunsch / Richiesta della combinazione dell'altro polo/ Demande de la combinaison de l'autre pôle / Demanda de la combinación del otro polo</p>
<p>Motor Seçenekleri Motor Options Motorauswahl Opzioni di motore Options de moteur Opciones de motor</p>	<p>BRE = Frenli / With brake / mit Bremsen / Freno / avec frein / Freno</p> <p>EF = Tek fazlı, fanlı / Separate fan, single phase / Separate Lüfter, einphasig / Ventilatore separato, monofase / Ventilateur séparé, une phase / Ventilador por separado de una sola fase</p> <p>ZF = Çift fazlı, fanlı / Separate fan, double phase / Separate Lüfter, Doppel-phase / Ventilatore separato, doppia fase Ventilateur séparé, double-phase / Ventilador por separado, de doble fase</p> <p>DF = Üç fazlı, fanlı / Separate fan, three phase / Separate Lüfter, drei-phase / Ventilatore separato, trifase / Ventilateur séparé, trois phases / Ventilador por separado, tres de fase</p> <p>IG = Enkoderli / With encoder / mit Encoder / Con encoder / avec codeur / con codificador</p> <p>KK/FK = Debriyajlı / With clutches / Mit Kupplungs / Con frizioni / embrayage / embrague</p> <p>SR = Toza karşı korumalı fren / Brake dust - proof / Staubgeschützte Bremse / Freno a prova di polvere / Frein à l'épreuve de la poussière / De frenos a prueba de polvo</p> <p>TF = Termistörlü / Thermistor / Thermistor / Termistore / Thermistance / Termistor</p> <p>RG = Korozyon korumalı frenli / Brake corrosion - protected / Mit Korrosionsschutzbremse / Freno resistente alla corrosione / Frein à la corrosion protégées / Freno protegida contra la corrosión</p> <p>WU = Yumuşak kalkışlı rotor / Soft start rotor / Sanftanlauf-rotor / Soft start rotore / Démarrage en douceur du rotor Soft desde el rotor</p> <p>B = Geri dönmeye karşı kilitli / Backstop / Rücklaufsperr / Bloccato contro il ritorno / Verrouillé contre le retour Bloqueado en contra de devolución</p> <p>TW = Isiya duyarlı / Thermal trip / Temperatursicherung / Un sensible al calore / A sensible à la chaleur / Un sensible al calor</p> <p>HL = Manuel frenli motor / Brake motor with hand release / Handbremsmotoren / Motore autofrenante mano / Moteur de frein à main / motores freno manuales</p>

TR AKSESUARLAR
IT ACCESSORI

EN ACCESSORIES
FR ACCESSOIRES

DE ZUBEHÖR
ES ACCESORIOS

1-3 Kademe / 1-3 Stage / 1-3 Übersetzungsstufen /
1-3 Stadi / 1-3 Trains / 1-3 Trenes

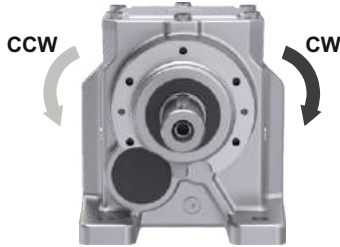

Çıkış tarafı / Output side / Ausgangseite /
Lato uscita / Côté sortie / Lado de salida

2 Kademe / 2 Stage / 2 Übersetzungsstufen /
2 Stadi / 2 Trains / 2 Trenes

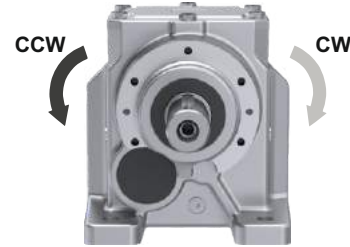

Çıkış tarafı / Output side / Ausgangseite /
Lato uscita / Côté sortie / Lado de salida

Kilit

Kilit redüktörün giriş miline takılabilir. Kilit çıkış kısmının istenilmeyen yöne doğru dönmesini engeller. Redüktörün büyüklüğüne göre kilit giriş flanşında veya motora takılır. İstenilen çıkış dönüş yönü bilgisi verilmelidir.

Backstop device

The gear reducer can be supplied with backstop device on input shaft. Backstop device allows output shaft rotation in only one sense of direction; according to the size, it is available in the input flange or in the motor with the same dimensions. It is important to specify the required sense of direction on the order.

Rücklaufsperr

Das Getriebe ist mit Rücklaufsperr auf der Antriebswelle erhältlich. Die Rücklaufsperr verhindert die Rotation in die falsche Drehrichtung. Entsprechend der Größe ist sie im Antriebsflansch oder dem Motor integriert. Wichtig ist die Angabe der gewünschten Abtriebsdrehrichtung.

Dispositivo antiretro

Il riduttore può essere fornito munito di dispositivo antiretro sull'asse veloce. L'antiretro permette la rotazione degli alberi in un solo senso, a seconda della grandezza è disponibile nella flangia PAM oppure nel motore, senza ingombri aggiuntivi. E' molto importante, in fase di ordine, specificare il senso di rotazione richiesto.

Système antidévoreur

Le réducteur de vitesse peut être fourni avec le dispositif antiretour sur l'axe d'entrée. Le dispositif anti retour permet la rotation des arbres de sortie dans un seul sens; selon la taille, il est disponible dans la bride d'entrée ou dans le moteur avec les mêmes dimensions. Il est important de spécifier le sens de la direction demandé sur l'ordre.

Dispositivo antirretorno

El reductor puede suministrarse con un dispositivo antirretorno en el eje veloz. El antirretorno permite la rotación de los ejes en un solo sentido, según el tamaño está disponible en la brida PAM o en el motor, sin incremento de dimensiones. Es muy importante especificar en el pedido el sentido de rotación requerido.

Motor	063	071	080	090	100 - 112	132	160	180	200	225
Gövde Boyutu / Größe / Size Grandezza / Taille / Tamaño	140x11	160x14	200x19	200x24	250x28	300x38	350x42	350x48	400x55	450x60
202	B5/B14	B5/B14								
202 G	B5/B14	B5/B14	B5/B14	B5/B14						
252		B5/B14	B5/B14	B5/B14	B5/B14					
253	B5/B14	B5/B14	B5/B14	B5/B14						
301		B5/B14	B5/B14	B5/B14						
302		B5/B14	B5/B14	B5/B14	B5/B14					
303	B5/B14	B5/B14	B5/B14	B5/B14						
351		B5/B14	B5/B14	B5/B14	B5/B14					
352		B5/B14	B5/B14	B5/B14	B5/B14					
353	B5/B14	B5/B14	B5/B14	B5/B14						
401			B5/B14	B5/B14	B5/B14					
402			B5/B14	B5/B14	B5/B14	B5/B14				
403		B5/B14	B5/B14	B5/B14	B5/B14					
501			B5/B14	B5/B14	B5/B14	B5/B14				
502			B5/B14	B5/B14	B5/B14	B5/B14	B5			
503			B5/B14	B5/B14	B5/B14	B5/B14				
601					B5/B14	B5/B14	B5	B5		
602					B5/B14	B5/B14	B5	B5		
603				B5/B14	B5/B14	B5/B14	B5			
701						B5/B14	B5	B5	B5	
702						B5/B14	B5	B5	B5	
703					B5/B14	B5/B14	B5	B5	B5	
902							B5	B5	B5	B5
903						B5/B14	B5	B5	B5	



A large area of the page is filled with horizontal dotted lines, providing a template for writing or drawing.

Motorlu Seçim Tabloları

Selection Tables of
Gearedmotors

Auswahltabellen der
Getriebemotoren

Tabelle di selezione dei
motoriduttori

Tables de Gearedmotors de
sélection

Tablas de selección de
gearedmotors

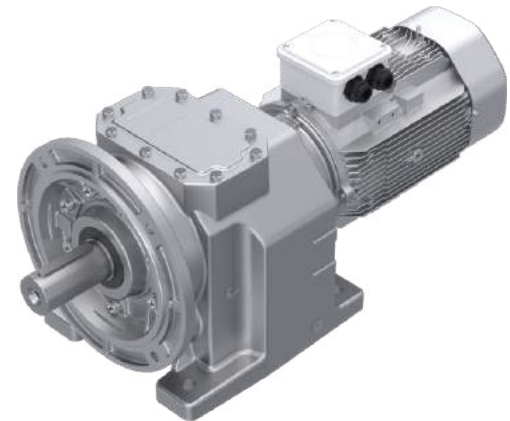
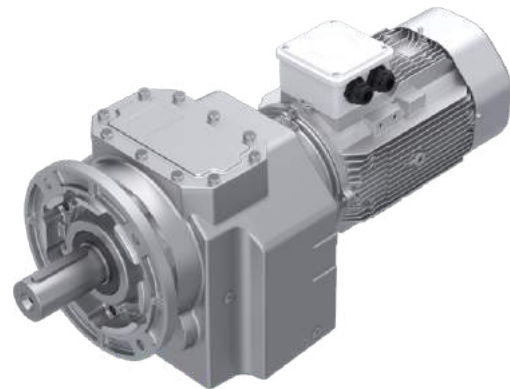
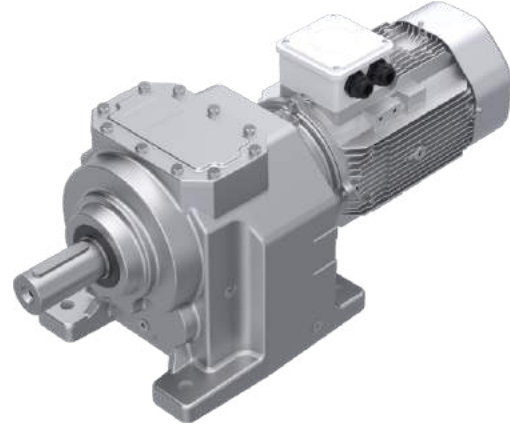

A/F

TR TEKNİK AÇIKLAMALAR
IT DESCRIZIONI TECNICHE

EN TECHNICAL DESCRIPTIONS
FR DESCRIPTIONS TECHNIQUES

DE TECHNISCHE BESCHREIBUNGEN
ES DESCRIPCIONES TECNICAS

Motorlu redüktör performans tablolarının yapısı

Notify about performance tables for Geared motor.

Aufbau der Leistungstafeln für Getriebemotor

Notificare sulle tabelle di performance per i motoriduttori

Aviser sur les tableaux de performance pour le motoréducteur

Notificar sobre la tabla de performance para los motoreductores.

1.10 kW →

Redüktör motor gücü

Gear unit motor power
Getriebe Motorleistung
Potenza motore riduttore
Potencia del motor del reductor
Réducteur puissance du moteur

P ₁ [kW]	n ₂ [Min ⁻¹]	M ₂ [Nm]	f _B	i _{ges}	FR (a) [kN]	Tip / Type / Typ / Tipo / Type / Tipo IE2 / IE3	kg ~	mm
1.10	6.3	1570	1.1	222.59	18.0	A/F 503 90L4B / 90L4C	57	134
	7.2	1374	1.3	194.86	18.0			
	7.8	1262	1.4	178.98	18.0			
	8.6	1144	1.6	162.21	18.0			
	9.1	1090	1.7	154.52	18.0			
	9.9	1002	1.8	142.00	18.0			
	11.3	876	2.1	124.25	18.0			
	12.4	794	2.3	112.61	18.0			
	14.3	690	2.6	97.80	18.0			
	16.4	602	3.0	85.33	18.0			

Tahvil oranı

Reduction ratio
Verkleinerungsfaktor
Rapporto di riduzione
Rapport de réduction
Relación de reducción

Servis faktörü

Service factor
Servicefaktor
Factor de servicio
Fattore di servizio
Facteur de service

Mil Çıkışlı

Solid shaft
Vollwelle
Albero pieno
Arbre en
Eje macizo

Müsaade edilebilir radyal yükler

Permissible radial force
Zulässige Radialkraft
Force radiale admissible
Fuerza radial admisible
Forza radiale ammessa

Çıkış momenti

Output torque
Abtriebsdrehmoment
Coppia di uscita
Par de salida
Couple de sortie

Çıkış devri

Output speed
Abtriebsdrehzahl
Vitesse de sortie
Velocità di uscita
Velocidad de salida

Redüktör tipi

Gear unit motor type
Getriebe Motortyp
Réducteur type de moteur
Reductor tipo de motor
Riduttore tipo di motore

Ağırlık



Weight
Gewicht
peso
poids
peso



Ölçü sayfaları

Drawing page
Zeichnungsseite
Pagina di disegno
Page de dessin
Pagina de diseño

Motor gücü



Rated motor power
Motormennleistung
Potenza nominale del motore
Puissance nominale du moteur
Potencia nominal del motor



P ₁ [kW]	n ₂ [Min ⁻¹]	M ₂ [Nm]	f _B	i _{ges}	FR (a) [kN]	Tip / Type / Typ / Tipo / Type / Tipo IE2 / IE3	 Kg ~	 mm
0.09	11.1	75	1.2	81.41	2.8	A/F 202 G 56M6	9	116
	12.8	65	1.2	70.05	2.8			
	14.4	58	1.2	62.38	2.8			
	16.7	50	1.8	54.05	2.8			
	19.4	43	2.1	46.41	2.8			
	21.7	38	2.3	41.38	2.8			
	24.2	34	2.6	37.17	2.8			
	26.5	32	2.9	34.00	2.8			
	17.2	48	1.7	81.41	2.5	A/F 202 G 56M4	9	116
	20.0	41	1.7	70.05	2.5			
	22.4	37	1.7	62.38	2.5			
	25.9	32	2.7	54.05	2.5			
	34.4	23	2.7	81.41	2.5	A/F 202 G 56M2	9	116
	40.0	20	2.7	70.05	2.5			
	44.9	18	2.7	62.38	2.5			
	14.2	59	0.9	63.59	2.5	A/F 202 56M6	7	114
	16.4	51	1.0	55.03	2.5			
	18.3	45	1.1	49.05	2.5			
	21.3	39	1.3	42.20	2.5			
	24.7	34	1.7	36.45	2.5			
	27.8	30	1.9	32.41	2.5			
	34.1	24	2.3	26.38	2.5			
	37.5	22	2.6	23.98	2.5			
	41.1	20	2.8	21.90	2.5			
42.1	20	2.9	21.36	2.5				
22.0	37	1.3	63.59	2.5	A/F 202 56M4	7	114	
25.4	32	1.5	55.03	2.5				
28.5	29	1.6	49.05	2.5				
33.2	25	2.0	42.20	2.5				
38.4	21	2.5	36.45	2.5				
43.2	19	2.9	32.41	2.5				
44.0	18	2.1	63.59	2.5	A/F 202 56M2	7	114	
50.9	16	2.4	55.03	2.5				
57.1	14	2.5	49.05	2.5				
0.12	3.4	326	1.6	268.00	8.0	A/F 353 63M6C / 63M6B	21	126
	4.2	264	2.0	216.67	8.0			
	4.6	237	2.2	194.72	8.0			
	5.7	192	2.7	157.42	8.0			
	5.2	206	2.4	268.00	8.0	A/F 353 63M4A	21	126
	6.5	167	3.0	216.67	8.0			
	3.2	343	0.9	282.17	6.6	A/F 303 63M6C / 63M6B	16	122
	4.0	277	1.1	227.56	6.6			
	4.4	249	1.3	205.01	6.6			
	5.4	201	1.6	165.33	6.6			
	6.3	173	1.8	141.89	6.6			
	7.2	153	2.1	125.65	6.6			
	7.9	139	2.3	114.42	6.6			
	10.3	106	3.0	86.96	6.6			
	5.0	217	1.4	282.17	6.6	A/F 303 63M4A	16	122
	6.2	175	1.7	227.56	6.6			
	6.8	158	1.9	205.01	6.6			
	8.5	127	2.4	165.33	6.6			
	9.9	109	2.7	141.89	6.6			
	4.6	240	0.9	197.21	5.5	A/F 253 63M6C / 63M6B	13	118
	5.0	217	1.0	178.56	5.5			
	6.3	174	1.2	143.29	5.5			
	7.3	150	1.4	123.58	5.5			
	8.3	131	1.6	108.02	5.5			
9.1	121	1.7	99.17	5.5				
12.0	91	2.3	74.76	5.5				
13.5	81	2.6	66.56	5.5				



P ₁ [kW]	n ₂ [Min ⁻¹]	M ₂ [Nm]	f _B	i _{ges}	FR (a) [kN]	Tip / Type / Typ / Tipo / Type / Tipo IE2 / IE3	 ~	
0.12	5.7	189	1.1	245.76	5.5	A/F 253 63M4A	13	118
	7.1	152	1.3	197.21	5.5			
	7.8	137	1.5	178.56	5.5			
	9.8	110	1.8	143.29	5.5			
	11.3	95	2.1	123.58	5.5			
	13.0	83	2.4	108.02	5.5			
	14.1	76	2.6	99.17	-			
	11.1	101	0.9	81.41	2.8	A/F 202 G 63M6C / 63M6B	8	116
	12.8	87	0.9	70.05	2.8			
	14.4	77	0.9	62.38	2.8			
	16.7	67	1.3	54.05	2.8			
	19.4	57	1.6	46.41	2.8			
	21.7	51	1.7	41.38	2.8			
	24.2	46	1.9	37.17	2.8			
	26.5	42	2.1	34.00	2.8			
	29.5	38	2.6	30.55	2.8			
	32.5	34	2.8	27.66	2.8			
	17.2	64	1.3	81.41	2.8	A/F 202 G 63M4A	8	116
	20.0	55	1.3	70.05	2.8			
	22.4	49	1.3	62.38	2.8			
	25.9	42	2.0	54.05	2.8			
	30.2	36	2.3	46.41	2.8			
	33.8	33	2.6	41.38	2.8			
	37.7	29	2.9	37.17	2.8			
	34.4	31	2.0	81.41	2.8	A/F 202 G 63M2K	8	116
	40.0	27	2.0	70.05	2.8			
	44.9	24	2.0	62.38	2.8			
	16.4	68	0.8	55.03	2.5	A/F 202 63M6C / 63M6B	7	114
	18.3	61	0.8	49.05	2.5			
	21.3	52	1.0	42.20	2.5			
	24.7	45	1.3	36.45	2.5			
	27.8	40	1.4	32.41	2.5			
	34.1	33	1.7	26.38	2.5			
	37.5	30	1.9	23.98	2.5			
	41.1	27	2.1	21.90	2.5			
	42.1	26	2.2	21.36	2.5			
46.8	24	2.4	19.23	2.5				
51.8	21	2.7	17.37	2.5				
57.1	19	3.0	15.75	2.5				
62.4	18	3.0	14.42	2.5				
68.0	16	3.0	13.23	2.5				
22.0	50	1.0	63.59	2.5	A/F 202 63M4A	7	114	
25.4	43	1.2	55.03	2.5				
28.5	39	1.2	49.05	2.5				
33.2	33	1.5	42.20	2.5				
38.4	29	1.9	36.45	2.5				
43.2	25	2.2	32.41	2.5				
53.1	21	2.6	26.38	2.5				
58.4	19	2.9	23.98	2.5				
44.0	24	1.6	63.59	2.5	A/F 202 63M2K	7	114	
50.9	21	1.8	55.03	2.5				
57.1	19	1.9	49.05	2.5				
66.4	16	2.4	42.20	2.5				
76.8	14	3.0	36.45	2.5				
0.18	3.4	489	1.1	268.00	8.0	A/F 353 71M6B / 71M6A	25	126
	4.2	395	1.3	216.67	8.0			
	4.6	355	1.5	194.72	8.0			
	5.7	287	1.8	157.42	8.0			
	6.7	246	2.1	134.76	8.0			
	8.3	199	2.6	108.95	8.0			
	5.2	309	1.6	268.00	8.0	A/F 353 63M4B	21	126
	6.5	250	2.0	216.67	8.0			
	7.2	225	2.2	194.72	8.0			
	8.9	182	2.8	157.42	8.0			
	10.4	148	2.6	268.00	8.0	A/F 353 63M2A	21	126



P₁ [kW]	n₂ [Min ⁻¹]	M₂ [Nm]	f_B	i_{ges}	FR (a) [kN]	Tip / Type / Typ / Tipo / Type / Tipo IE2 / IE3	Kg ~	mm
0.18	4.0	415	0.8	227.56	6.6	A/F 303 71M6B / 71M6A	20	122
	4.4	374	0.8	205.01	6.6			
	5.4	302	1.0	165.33	6.6			
	6.3	259	1.2	141.89	6.6			
	7.2	229	1.4	125.65	6.6			
	7.9	209	1.5	114.42	6.6			
	10.3	159	2.0	86.96	6.6			
	11.8	139	2.3	76.42	6.6			
	14.6	112	2.8	61.63	6.6			
		5.0	326	0.9	282.17			
	6.2	263	1.1	227.56	6.6			
	6.8	237	1.3	205.01	6.6			
	8.5	191	1.6	165.33	6.6			
	9.9	164	1.8	141.89	6.6			
	11.1	145	2.1	125.65	6.6			
	12.2	132	2.3	114.42	6.6			
	16.1	100	3.0	86.96	6.6			
	9.9	156	1.5	282.17	6.6	A/F 303 63M2A	16	122
	12.3	126	1.8	227.56	6.6			
	13.7	113	2.0	205.01	6.6			
	16.9	91	2.5	165.33	6.6			
	19.7	78	2.9	141.89	6.6			
	6.3	262	0.8	143.29	5.5	A/F 253 71M6B / 71M6A	17	118
	7.3	226	0.9	123.58	5.5			
	8.3	197	1.1	108.02	5.5			
	9.1	181	1.1	99.17	5.5			
	12.0	136	1.5	74.76	5.5			
	13.5	121	1.7	66.56	5.5			
	16.9	97	2.2	53.41	5.5			
	7.1	228	0.9	197.21	5.5	A/F 253 63M4B	13	118
	7.8	206	1.0	178.56	5.5			
	9.8	165	1.2	143.29	5.5			
	11.3	143	1.4	123.58	5.5			
	13.0	125	1.6	108.02	5.5			
	14.1	115	1.7	99.17	-			
	18.7	86	2.3	74.76	5.5			
	21.0	77	2.6	66.56	5.5			
	11.4	136	1.1	245.76	5.5	A/F 253 63M2A	13	118
	14.2	109	1.4	197.21	5.5			
	15.7	99	1.5	178.56	5.5			
	19.5	79	1.9	143.29	5.5			
	22.7	68	2.2	123.58	5.5			
	25.9	60	2.6	108.02	5.5			
	28.2	55	2.8	99.17	5.5			
	16.7	100	0.9	54.05	2.8			
	19.4	86	1.0	46.41	2.8			
	21.7	77	1.2	41.38	2.8			
	24.2	69	1.3	37.17	2.8			
	26.5	63	1.4	34.00	2.8			
	29.5	57	1.7	30.55	2.8			
	32.5	51	1.9	27.66	2.8			
	36.2	46	2.1	24.83	2.8			
	40.1	42	2.3	22.44	2.8			
	44.2	38	2.4	20.35	2.8			
	48.3	35	2.6	18.63	2.8			
	17.2	96	0.9	81.41	2.8	A/F 202 G 63M4B	8	116
	20.0	83	0.9	70.05	2.8			
	22.4	74	0.9	62.38	2.8			
	25.9	64	1.3	54.05	2.8			
	30.2	55	1.6	46.41	2.8			
	33.8	49	1.7	41.38	2.8			
	37.7	44	1.9	37.17	2.8			
	41.2	40	2.1	34.00	2.8			
	45.8	36	2.6	30.55	2.8			
	50.6	33	2.8	27.66	2.8			

P₁ [kW]	n₂ [Min ⁻¹]	M₂ [Nm]	f_B	i_{ges}	FR (a) [kN]	Tip / Type / Typ / Tipo / Type / Tipo IE2 / IE3	Kg ~	mm
0.18	34.4	47	1.4	81.41	2.8	A/F 202 G 63M2A	8	116
	40.0	40	1.4	70.05	2.8			
	44.9	36	1.4	62.38	2.8			
	51.8	31	2.1	54.05	2.8			
	60.3	27	2.4	46.41	2.8			
	67.7	24	2.7	41.38	2.8			
	75.3	21	3.0	37.17	2.8			
	34.1	49	1.2	26.38	2.5	A/F 202 71M6B / 71M6A	10	114
	37.5	44	1.3	23.98	2.5			
	41.1	41	1.4	21.90	2.5			
	42.1	40	1.5	21.36	2.5			
	46.8	36	1.6	19.23	2.5			
	51.8	32	1.8	17.37	2.5			
	57.1	29	2.0	15.75	2.5			
	62.4	27	2.0	14.42	2.5			
	68.0	25	2.0	13.23	2.5			
	78.1	21	2.5	11.52	2.5			
	25.4	65	0.8	55.03	2.5	A/F 202 63M4B	7	114
	28.5	58	0.8	49.05	2.5			
	33.2	50	1.0	42.20	2.5			
	38.4	43	1.3	36.45	2.5			
	43.2	38	1.4	32.41	2.5			
	53.1	31	1.7	26.38	2.5			
	58.4	28	1.9	23.98	2.5			
	63.9	26	2.1	21.90	2.5			
	65.5	25	2.2	21.36	2.5			
	72.8	23	2.4	19.23	2.5			
	80.6	20	2.7	17.37	2.5			
	88.9	19	3.0	15.75	2.5			
	97.1	17	3.0	14.42	2.5			
	105.8	16	3.0	13.23	2.5			
	44.0	36	1.0	63.59	2.5	A/F 202 63M2A	7	114
	50.9	31	1.2	55.03	2.5			
	57.1	28	1.2	49.05	2.5			
	66.4	24	1.6	42.20	2.5			
	76.8	21	2.0	36.45	2.5			
86.4	19	2.3	32.41	2.5				
106.1	15	2.7	26.38	2.5				
116.8	14	3.0	23.98	2.5				
0.25	3.4	679	1.3	267.75	12.0	A/F 403 71M6C / 71M6D	34	130
	3.8	595	1.5	234.50	12.0			
	4.2	545	1.6	215.01	12.0			
	4.8	472	1.9	186.14	12.0			
	5.3	432	2.1	170.55	12.0			
	6.0	379	2.4	149.47	12.0			
	6.6	343	2.6	135.37	12.0			
	7.6	299	3.0	118.13	12.0			
	5.2	429	2.0	267.75	12.0	A/F 403 71M4A / 71M4B	34	130
	6.0	376	2.3	234.50	12.0			
	6.5	345	2.5	215.01	12.0			
	7.5	298	2.8	186.14	12.0			
	3.4	679	0.8	268.00	8.0	A/F 353 71M6C / 71M6D	25	126
	4.2	549	1.0	216.67	8.0			
	4.6	494	1.1	194.72	8.0			
	5.7	399	1.3	157.42	8.0			
	6.7	342	1.5	134.76	8.0			
	8.3	276	1.9	108.95	8.0			
	9.9	229	2.3	90.51	8.0			
	12.4	184	2.9	72.58	8.0			
	5.2	430	1.2	268.00	8.0	A/F 353 71M4A / 71M4B	25	126
	6.5	347	1.4	216.67	8.0			
	7.2	312	1.6	194.72	8.0			
	8.9	252	2.0	157.42	8.0			
10.4	216	2.3	134.76	8.0				
12.8	175	2.9	108.95	8.0				
10.4	205	1.9	268.00	8.0	A/F 353 63M2B	21	126	
12.9	166	2.3	216.67	8.0				
14.4	149	2.5	194.72	8.0				



P ₁ [kW]	n ₂ [Min ⁻¹]	M ₂ [Nm]	f _B	i _{ges}	FR (a) [kN]	Tip / Type / Typ / Tipo / Type / Tipo IE2 / IE3	 Kg ~	 mm
0.25	5.4	419	0.8	165.33	6.6	A/F 303 71M6C / 71M6D	20	122
	6.3	360	0.9	141.89	6.6			
	7.2	319	1.0	125.65	6.6			
	7.9	290	1.1	114.42	6.6			
	10.3	220	1.4	86.96	6.6			
	11.8	194	1.6	76.42	6.6			
	14.6	156	2.0	61.63	6.6			
	6.2	365	0.8	227.56	6.6	A/F 303 71M4A / 71M4B	20	122
	6.8	329	0.9	205.01	6.6			
	8.5	265	1.1	165.33	6.6			
	9.9	227	1.3	141.89	6.6			
	11.1	201	1.5	125.65	6.6			
	12.2	183	1.6	114.42	6.6			
	16.1	139	2.2	86.96	6.6			
	18.3	123	2.4	76.42	6.6			
22.7	99	3.0	61.63	6.6				
9.9	216	1.1	282.17	6.6	A/F 303 63M2B	16	122	
12.3	174	1.3	227.56	6.6				
13.7	157	1.5	205.01	6.6				
16.9	127	1.8	165.33	6.6				
19.7	109	2.1	141.89	6.6				
22.3	96	2.4	125.65	6.6				
24.5	88	2.6	114.42	6.6				
16.4	142	2.1	55.03	6.6	A/F 302 71M6C / 71M6D	20	122	
18.7	124	2.4	48.22	6.6				
20.3	114	2.6	44.38	6.6				
23.5	99	3.0	38.33	6.6				
101.4	23	2.5	8.88	1.0	A/F 301 71M6C / 71M6D	14	120	
115.7	20	2.6	7.78	1.0				
8.3	274	0.8	108.02	5.5	A/F 253 71M6C / 71M6D	17	118	
9.1	252	0.8	99.17	5.5				
12.0	190	1.1	74.76	5.5				
13.5	169	1.2	66.56	5.5				
16.9	135	1.6	53.41	5.5				
9.8	230	0.9	143.29	5.5	A/F 253 71M4A / 71M4B	17	118	
11.3	198	1.0	123.58	5.5				
13.0	173	1.2	108.02	5.5				
14.1	158	1.2	99.17	-				
18.7	120	1.7	74.76	5.5				
21.0	107	1.9	66.56	5.5				
26.2	86	2.3	53.41	5.5				
11.4	188	0.8	245.76	5.5	A/F 253 63M2B	13	118	
14.2	151	1.0	197.21	5.5				
15.7	137	1.1	178.56	5.5				
19.5	110	1.4	143.29	5.5				
22.7	95	1.6	123.58	5.5				
25.9	83	1.8	108.02	5.5				
28.2	76	2.0	99.17	5.5				
37.5	57	2.7	74.76	5.5				
42.1	51	3.0	66.56	5.5				
18.8	123	1.7	47.93	5.5				A/F 252 71M6C / 71M6D
21.4	108	1.9	42.00	5.5				
23.4	99	2.1	38.46	5.5				
27.0	86	2.4	33.38	5.5				
29.9	78	2.7	30.15	5.5				
33.6	69	3.0	26.79	5.5				
33.3	69	2.9	42.00	5.5	A/F 252 71M4A / 71M4B	17	118	
29.2	78	2.5	47.93	5.5				



P ₁ [kW]	n ₂ [Min ⁻¹]	M ₂ [Nm]	f _B	i _{ges}	FR (a) [kN]	Tip / Type / Typ / Tipo / Type / Tipo IE2 / IE3	 ~	
0.25	21.7	107	0.8	41.38	2.8	A/F 202 G 71M6C / 71M6D	12	116
	24.2	96	0.9	37.17	2.8			
	26.5	88	1.0	34.00	2.8			
	29.5	79	1.2	30.55	2.8			
	32.5	71	1.4	27.66	2.8			
	36.2	64	1.5	24.83	2.8			
	40.1	58	1.7	22.44	2.8			
	44.2	52	1.7	20.35	2.8			
	48.3	48	1.8	18.63	2.8			
	57.2	41	2.2	15.74	2.8			
	66.4	35	2.6	13.56	2.8			
	74.4	31	2.9	12.09	2.8			
	78.9	29	3.0	11.41	2.8			
	25.9	88	1.0	54.05	2.8	A/F 202 G 71M4A / 71M4B	12	116
	30.2	76	1.1	46.41	2.8			
	33.8	68	1.3	41.38	2.8			
	37.7	61	1.4	37.17	2.8			
	41.2	56	1.5	34.00	2.8			
	45.8	50	1.8	30.55	2.8			
	50.6	45	2.0	27.66	2.8			
	56.4	41	2.3	24.83	2.8			
	62.4	37	2.5	22.44	2.8			
	68.8	33	2.6	20.35	2.8			
	75.1	30	2.8	18.63	2.8			
	34.4	65	1.0	81.41	2.8	A/F 202 G 63M2B	8	116
	40.0	56	1.0	70.05	2.8			
	44.9	50	1.0	62.38	2.8			
	51.8	43	1.5	54.05	2.8			
	60.3	37	1.8	46.41	2.8			
	67.7	33	2.0	41.38	2.8			
	75.3	30	2.2	37.17	2.8			
	82.4	27	2.4	34.00	2.8			
	91.7	24	2.9	30.55	2.8			
	34.1	68	0.8	26.38	2.5	A/F 202 71M6C / 71M6D	10	114
	37.5	62	0.9	23.98	2.5			
	41.1	56	1.0	21.90	2.5			
	42.1	55	1.1	21.36	2.5			
	46.8	49	1.2	19.23	2.5			
	51.8	45	1.3	17.37	2.5			
	57.1	41	1.4	15.75	2.5			
	62.4	37	1.4	14.42	2.5			
	68.0	34	1.4	13.23	2.5			
	78.1	30	1.8	11.52	2.5			
	89.7	26	2.2	10.03	2.5			
	100.8	23	2.5	8.93	2.5			
	112.1	21	2.8	8.03	2.5			
	53.1	43	1.3	26.38	2.5	A/F 202 71M4A / 71M4B	10	114
	58.4	39	1.4	23.98	2.5			
	63.9	36	1.5	21.90	2.5			
	65.5	35	1.6	21.36	2.5			
	72.8	31	1.7	19.23	2.5			
	80.6	28	1.9	17.37	2.5			
	88.9	26	2.1	15.75	2.5			
	97.1	24	2.2	14.42	2.5			
	105.8	22	2.2	13.23	2.5			
	121.5	19	2.7	11.52	2.5			
	44.0	50	0.8	63.59	2.5	A/F 202 63M2B	7	114
	50.9	44	0.9	55.03	2.5			
	57.1	39	0.9	49.05	2.5			
	66.4	34	1.1	42.20	2.5			
	76.8	29	1.4	36.45	2.5			
	86.4	26	1.6	32.41	2.5			
	106.1	21	2.0	26.38	2.5			
	116.8	19	2.2	23.98	2.5			
	127.9	17	2.4	21.90	2.5			
	131.1	17	2.5	21.36	2.5			
	145.6	15	2.7	19.23	2.5			
	161.2	14	3.0	17.37	2.5			

P ₁ [kW]	n ₂ [Min ⁻¹]	M ₂ [Nm]	f _B	i _{ges}	FR (a) [kN]	Tip / Type / Typ / Tipo / Type / Tipo IE2 / IE3	 Kg ~	 mm
0.37	3.4	1005	0.9	267.75	12.0	A/F 403 80M6A	35	130
	3.8	880	1.0	234.50	12.0			
	4.2	807	1.1	215.01	12.0			
	4.8	698	1.3	186.14	12.0			
	5.3	640	1.4	170.55	12.0			
	6.0	561	1.6	149.47	12.0			
	6.6	508	1.8	135.37	12.0			
	7.6	443	2.0	118.13	12.0			
	9.5	356	2.5	94.86	12.0			
	10.5	322	2.8	85.91	12.0			
	5.2	635	1.3	267.75	12.0	A/F 403 71M4B / 71M4C	34	130
	6.0	556	1.5	234.50	12.0			
	6.5	510	1.7	215.01	12.0			
	7.5	442	1.9	186.14	12.0			
	8.2	405	2.1	170.55	12.0			
	9.4	355	2.4	149.47	12.0			
	10.3	321	2.6	135.37	12.0			
	11.9	280	3.0	118.13	12.0			
	10.5	304	2.1	267.75	12.0	A/F 403 71M2A	34	130
	11.9	266	2.4	234.50	12.0			
	13.0	244	2.6	215.01	12.0			
	6.7	506	1.0	134.76	8.0	A/F 353 80M6A	26	126
	8.3	409	1.3	108.95	8.0			
	9.9	340	1.5	90.51	8.0			
	12.4	272	1.9	72.58	8.0			
	15.3	220	2.4	58.68	8.0			
	5.2	636	0.8	268.00	8.0	A/F 353 71M4B / 71M4C	25	126
	6.5	514	1.0	216.67	8.0			
	7.2	462	1.1	194.72	8.0			
	8.9	373	1.3	157.42	8.0			
	10.4	320	1.6	134.76	8.0			
	12.8	258	1.9	108.95	8.0			
	15.5	215	2.3	90.51	8.0			
	19.3	172	2.9	72.58	8.0			
	10.4	304	1.3	268.00	8.0	A/F 353 71M2A	25	126
	12.9	246	1.5	216.67	8.0			
	14.4	221	1.7	194.72	8.0			
	17.8	179	2.1	157.42	8.0			
	20.8	153	2.5	134.76	8.0			
	15.8	217	2.4	56.95	8.0	A/F 352 80M6A	26	126
	18.0	190	2.7	49.88	8.0			
	19.5	175	2.9	46.04	8.0			
10.3	326	1.0	86.96	6.6	A/F 303 80M6A	21	122	
11.8	287	1.1	76.42	6.6				
14.6	231	1.4	61.63	6.6				
8.5	392	0.8	165.33	6.6	A/F 303 71M4B / 71M4C	20	122	
9.9	337	0.9	141.89	6.6				
11.1	298	1.0	125.65	6.6				
12.2	271	1.1	114.42	6.6				
16.1	206	1.5	86.96	6.6				
18.3	181	1.7	76.42	6.6				
22.7	146	2.1	61.63	6.6				
12.3	258	0.9	227.56	6.6	A/F 303 71M2A	20	122	
13.7	232	1.0	205.01	6.6				
16.9	187	1.2	165.33	6.6				
19.7	161	1.4	141.89	6.6				
22.3	142	1.6	125.65	6.6				
24.5	130	1.8	114.42	6.6				
32.2	99	2.3	86.96	6.6				
36.6	87	2.6	76.42	6.6				
16.4	210	1.4	55.03	6.6				A/F 302 80M6A
18.7	184	1.6	48.22	6.6				
20.3	169	1.7	44.38	6.6				
23.5	146	2.0	38.33	6.6				
26.0	132	2.2	34.62	6.6				
29.1	118	2.5	30.91	6.6				
32.2	106	2.8	27.92	6.6				
34.0	101	2.7	26.45	6.6				



P_1 [kW]	n_2 [Min ⁻¹]	M_2 [Nm]	f_B	i_{ges}	FR (a) [kN]	Tip / Type / Typ / Tipo / Type / Tipo IE2 / IE3	 ~	
0.37	25.4	133	2.1	55.03	6.6	A/F 302 71M4B / 71M4C	20	122
	29.0	117	2.4	48.22	6.6			
	31.5	108	2.6	44.38	6.6			
	36.5	93	3.0	38.33	6.6			
	101.4	34	1.7	8.88	1.0	A/F 301 80M6A	15	120
	115.7	30	1.7	7.78	1.0			
	145.6	24	2.2	6.18	1.0			
	161.3	22	2.4	5.58	1.0			
	177.2	20	2.4	5.08	1.0			
	210.8	17	2.9	4.27	1.0			
	326.1	11	3.0	2.76	1.0			
	157.7	22	2.5	8.88	1.0	A/F 301 71M4B / 71M4C	14	120
	179.9	19	2.6	7.78	1.0			
	13.5	250	0.8	66.56	5.5	A/F 253 80M6A	18	118
	16.9	200	1.0	53.41	5.5			
	13.0	256	0.8	108.02	5.5	A/F 253 71M4B / 71M4C	17	118
	14.1	236	0.8	99.17	-			
	18.7	177	1.1	74.76	5.5			
	21.0	158	1.3	66.56	5.5			
	26.2	127	1.6	53.41	5.5			
	15.7	202	0.8	178.56	5.5	A/F 253 71M2A	17	118
	19.5	162	0.9	143.29	5.5			
	22.7	140	1.1	123.58	5.5			
	25.9	122	1.2	108.02	5.5			
	28.2	112	1.4	99.17	5.5			
	37.5	85	1.8	74.76	5.5			
	42.1	75	2.0	66.56	5.5			
	52.4	61	2.5	53.41	5.5			
18.8	183	1.2	47.93	5.5	A/F 252 80M6A	18	118	
21.4	160	1.3	42.00	5.5				
23.4	147	1.4	38.46	5.5				
27.0	127	1.7	33.38	5.5				
29.9	115	1.8	30.15	5.5				
33.6	102	2.1	26.79	5.5				
37.2	92	2.3	24.19	5.5				
39.1	88	2.4	23.04	5.5				
44.6	77	2.7	20.19	5.5				
48.7	70	3.0	18.49	5.5				
29.2	116	1.7	47.93	5.5	A/F 252 71M4B / 71M4C	17	118	
33.3	102	2.0	42.00	5.5				
36.4	93	2.1	38.46	5.5				
41.9	81	2.5	33.38	5.5				
46.4	73	2.7	30.15	5.5				
58.4	56	2.7	47.93	5.5	A/F 252 71M2A	17	118	
32.5	105	0.9	27.66	2.8	A/F 202 G 80M6A	13	116	
36.2	95	1.0	24.83	2.8				
40.1	85	1.1	22.44	2.8				
44.2	78	1.2	20.35	2.8				
48.3	71	1.2	18.63	2.8				
57.2	60	1.5	15.74	2.8				
66.4	52	1.7	13.56	2.8				
74.4	46	2.0	12.09	2.8				
78.9	43	2.1	11.41	2.8				
82.9	41	2.2	10.85	2.8				
91.7	37	2.4	9.81	2.8				
102.9	33	2.8	8.75	2.8				
115.2	30	2.9	7.81	2.8				



P₁ [kW]	n₂ [Min ⁻¹]	M₂ [Nm]	f_B	i_{ges}	FR (a) [kN]	Tip / Type / Typ / Tipo / Type / Tipo IE2 / IE3	Kg ~	mm			
0.37	30.2	112	0.8	46.41	2.8	A/F 202 G 71M4B / 71M4C	12	116			
	33.8	100	0.8	41.38	2.8						
	37.7	90	0.9	37.17	2.8						
	41.2	82	1.0	34.00	2.8						
	45.8	74	1.2	30.55	2.8						
	50.6	67	1.4	27.66	2.8						
	56.4	60	1.5	24.83	2.8						
	62.4	54	1.7	22.44	2.8						
	68.8	49	1.7	20.35	2.8						
	75.1	45	1.9	18.63	2.8						
	88.9	38	2.2	15.74	2.8						
	103.2	33	2.6	13.56	2.8						
	115.8	29	3.0	12.09	2.8						
	51.8	64	1.0	54.05	2.8	A/F 202 G 71M2A	12	116			
	60.3	55	1.2	46.41	2.8						
	67.7	49	1.3	41.38	2.8						
	75.3	44	1.5	37.17	2.8						
	82.4	40	1.6	34.00	2.8						
	91.7	36	1.9	30.55	2.8						
	101.2	33	2.2	27.66	2.8						
	112.8	29	2.4	24.83	2.8						
	124.8	26	2.7	22.44	2.8						
	137.6	24	2.7	20.35	2.8						
	150.3	22	2.9	18.63	2.8						
	53.1	64	0.8	26.38	2.5				A/F 202 71M4B / 71M4C	10	114
	58.4	58	0.9	23.98	2.5						
	63.9	53	1.0	21.90	2.5						
	65.5	52	1.1	21.36	2.5						
	72.8	47	1.2	19.23	2.5						
	80.6	42	1.3	17.37	2.5						
	88.9	38	1.4	15.75	2.5						
	97.1	35	1.5	14.42	2.5						
	105.8	32	1.5	13.23	2.5						
	121.5	28	1.8	11.52	2.5						
	139.6	24	2.3	10.03	2.5						
	156.8	22	2.5	8.93	2.5						
	174.3	19	2.8	8.03	2.5						
	106.1	31	1.3	26.38	2.5	A/F 202 71M2A	10	114			
	116.8	28	1.5	23.98	2.5						
	127.9	26	1.6	21.90	2.5						
	131.1	25	1.7	21.36	2.5						
	145.6	23	1.8	19.23	2.5						
161.2	20	2.0	17.37	2.5							
177.8	19	2.3	15.75	2.5							
194.2	17	2.3	14.42	2.5							
211.6	16	2.3	13.23	2.5							
243.1	14	2.8	11.52	2.5							
0.55	4.0	1241	1.5	222.59	18.0				A/F 503 80M6B	52	134
	4.6	1087	1.7	194.86	18.0						
	5.0	998	1.9	178.98	18.0						
	5.5	905	2.1	162.21	18.0						
	5.8	862	2.2	154.52	18.0						
	6.3	792	2.4	142.00	18.0						
	7.2	693	2.7	124.25	18.0						
	8.0	628	3.0	112.61	18.0						
	6.3	785	2.3	222.59	18.0	A/F 503 80M4B / 80M4C	52	134			
	7.2	687	2.6	194.86	18.0						
	7.8	631	2.9	178.98	18.0						
	4.8	1038	0.9	186.14	12.0	A/F 403 80M6B	35	130			
	5.3	951	0.9	170.55	12.0						
	6.0	834	1.1	149.47	12.0						
	6.6	755	1.2	135.37	12.0						
	7.6	659	1.4	118.13	12.0						
	9.5	529	1.7	94.86	12.0						
	10.5	479	1.9	85.91	12.0						
	13.2	381	2.3	68.25	12.0						
	16.4	306	2.9	54.81	12.0						



P_1 [kW]	n_2 [Min ⁻¹]	M_2 [Nm]	f_B	i_{ges}	FR (a) [kN]	Tip / Type / Typ / Tipo / Type / Tipo IE2 / IE3	 Kg ~	 mm			
0.55	5.2	944	0.9	267.75	12.0	A/F 403 80M4B / 80M4C	35	130			
	6.0	827	1.0	234.50	12.0						
	6.5	758	1.1	215.01	12.0						
	7.5	656	1.3	186.14	12.0						
	8.2	601	1.4	170.55	12.0						
	9.4	527	1.6	149.47	12.0						
	10.3	477	1.8	135.37	12.0						
	11.9	417	2.0	118.13	12.0						
	14.8	335	2.5	94.86	12.0						
	16.3	303	2.8	85.91	12.0						
	10.5	451	1.4	267.75	12.0				A/F 403 71M2B	34	130
	11.9	395	1.6	234.50	12.0						
	13.0	362	1.8	215.01	12.0						
	15.0	314	2.1	186.14	12.0						
	16.4	288	2.2	170.55	12.0						
	18.7	252	2.6	149.47	12.0						
	20.7	228	2.8	135.37	12.0						
	8.3	608	0.9	108.95	8.0	A/F 353 80M6B	26	126			
	9.9	505	1.0	90.51	8.0						
	12.4	405	1.3	72.58	8.0						
	15.3	327	1.6	58.68	8.0						
	10.4	475	1.1	134.76	8.0	A/F 353 80M4B / 80M4C	26	126			
	12.8	384	1.3	108.95	8.0						
	15.5	319	1.6	90.51	8.0						
	19.3	256	2.0	72.58	8.0						
	23.9	207	2.4	58.68	8.0						
	10.4	452	0.8	268.00	8.0	A/F 353 71M2B	25	126			
	12.9	365	1.0	216.67	8.0						
	14.4	328	1.2	194.72	8.0						
	17.8	265	1.4	157.42	8.0						
	20.8	227	1.7	134.76	8.0						
	25.7	184	2.1	108.95	8.0						
	30.9	153	2.5	90.51	8.0						
	15.8	322	1.6	56.95	8.0	A/F 352 80M6B	26	126			
	18.0	282	1.8	49.88	8.0						
	19.5	261	2.0	46.04	8.0						
	22.7	224	2.3	39.59	8.0						
	26.9	190	2.7	33.50	8.0						
	28.1	181	2.8	32.01	8.0						
	24.6	205	2.4	56.95	8.0	A/F 352 80M4B / 80M4C	26	126			
	28.1	180	2.7	49.88	8.0						
	30.4	166	3.0	46.04	8.0						
	105.9	49	2.1	8.50	2.5	A/F 351 80M6B	17	124			
	121.0	43	2.5	7.44	2.5						
	14.6	344	0.9	61.63	6.6	A/F 303 80M6B	21	122			
	16.1	307	1.0	86.96	6.6	A/F 303 80M4B / 80M4C	21	122			
	18.3	270	1.1	76.42	6.6						
	22.7	217	1.4	61.63	6.6						
16.9	279	0.8	165.33	6.6	A/F 303 71M2B	20	122				
19.7	239	1.0	141.89	6.6							
22.3	212	1.1	125.65	6.6							
24.5	193	1.2	114.42	6.6							
32.2	147	1.6	86.96	6.6							
36.6	129	1.8	76.42	6.6							
45.4	104	2.2	61.63	6.6							
16.4	312	0.9	55.03	6.6	A/F 302 80M6B	21	122				
18.7	273	1.1	48.22	6.6							
20.3	251	1.2	44.38	6.6							
23.5	217	1.4	38.33	6.6							
26.0	196	1.5	34.62	6.6							
29.1	175	1.7	30.91	6.6							
32.2	158	1.9	27.92	6.6							
34.0	150	1.8	26.45	6.6							
38.3	133	2.1	23.49	6.6							
42.2	121	2.2	21.33	6.6							
46.7	109	2.4	19.29	6.6							
55.5	92	2.9	16.21	6.6							



P ₁ [kW]	n ₂ [Min ⁻¹]	M ₂ [Nm]	f _B	i _{ges}	FR (a) [kN]	Tip / Type / Typ / Tipo / Type / Tipo IE2 / IE3	 ~	
0.55	25.4	198	1.4	55.03	6.6	A/F 302 80M4B / 80M4C	21	122
	29.0	174	1.6	48.22	6.6			
	31.5	160	1.8	44.38	6.6			
	36.5	138	2.0	38.33	6.6			
	40.4	125	2.2	34.62	6.6			
	45.3	111	2.5	30.91	6.6			
	50.1	101	2.8	27.92	6.6			
	52.9	95	2.7	26.45	6.6			
	50.9	96	2.2	55.03	6.6	A/F 302 71M2B	20	122
	58.1	84	2.5	48.22	6.6			
	63.1	78	2.7	44.38	6.6			
	101.4	51	1.1	8.88	1.0	A/F 301 80M6B	15	120
	115.7	45	1.2	7.78	1.0			
	145.6	36	1.5	6.18	1.0			
	161.3	32	1.6	5.58	1.0			
	177.2	29	1.6	5.08	1.0			
	210.8	25	1.9	4.27	1.0			
	246.6	21	2.3	3.65	1.0			
	284.8	18	2.3	3.16	1.0			
	326.1	16	2.0	2.76	0.9			
	347.5	15	2.1	2.59	0.9			
	441.2	12	2.2	2.04	0.9			
	157.7	33	1.7	8.88	1.0	A/F 301 80M4B / 80M4C	15	120
	179.9	29	1.7	7.78	1.0			
	226.5	23	2.2	6.18	1.0			
	250.9	21	2.4	5.58	1.0			
	275.6	19	2.4	5.08	1.0			
	327.9	16	2.9	4.27	1.0			
	507.2	10	3.0	2.76	0.9			
	315.3	16	2.6	8.88	1.0	A/F 301 71M2B	14	120
	359.9	14	2.7	7.78	1.0			
	18.7	264	0.8	74.76	5.5	A/F 253 80M4B / 80M4C	18	118
	21.0	235	0.9	66.56	5.5			
	26.2	188	1.1	53.41	5.5			
	25.9	182	0.8	108.02	5.5	A/F 253 71M2B	17	118
	28.2	167	0.9	99.17	5.5			
	37.5	126	1.2	74.76	5.5			
	42.1	112	1.4	66.56	5.5			
	52.4	90	1.7	53.41	5.5			
	18.8	271	0.8	47.93	5.5	A/F 252 80M6B	18	118
	21.4	238	0.9	42.00	5.5			
	23.4	218	1.0	38.46	5.5			
	27.0	189	1.1	33.38	5.5			
	29.9	171	1.2	30.15	5.5			
	33.6	152	1.4	26.79	5.5			
	37.2	137	1.5	24.19	5.5			
	39.1	130	1.6	23.04	5.5			
44.6	114	1.8	20.19	5.5				
48.7	105	2.0	18.49	5.5				
52.8	97	2.1	17.05	5.5				
60.4	84	2.1	14.91	5.5				
64.6	79	2.3	13.94	5.5				
75.2	68	2.2	11.97	5.5				
87.2	58	2.5	10.32	5.5				
99.8	51	2.7	9.02	5.5				
113.5	45	2.9	7.93	5.5				
29.2	173	1.2	47.93	5.5	A/F 252 80M4B / 80M4C	18	118	
33.3	151	1.3	42.00	5.5				
36.4	139	1.4	38.46	5.5				
41.9	120	1.7	33.38	5.5				
46.4	109	1.8	30.15	5.5				
52.3	96	2.1	26.79	5.5				
57.9	87	2.3	24.19	5.5				
60.8	83	2.4	23.04	5.5				
69.3	73	2.8	20.19	5.5				
75.7	67	3.0	18.49	5.5				



P ₁ [kW]	n ₂ [Min ⁻¹]	M ₂ [Nm]	f _B	i _{ges}	FR (a) [kN]	Tip / Type / Typ / Tipo / Type / Tipo IE2 / IE3	~	
0.55	58.4	84	1.8	47.93	5.5	A/F 252 71M2B	17	118
	66.7	73	2.1	42.00	5.5			
	72.8	67	2.3	38.46	5.5			
	83.9	58	2.6	33.38	5.5			
	92.9	53	2.9	30.15	5.5			
	40.1	127	0.8	22.44	2.8	A/F 202 G 80M6B	13	116
	44.2	115	0.8	20.35	2.8			
	48.3	105	0.8	18.63	2.8			
	57.2	89	1.0	15.74	2.8			
	66.4	77	1.2	13.56	2.8			
	74.4	68	1.3	12.09	2.8			
	78.9	65	1.4	11.41	2.8			
	82.9	61	1.5	10.85	2.8			
	91.7	56	1.6	9.81	2.8			
	102.9	50	1.9	8.75	2.8			
	115.2	44	1.9	7.81	2.8			
	127.8	40	2.2	7.04	2.8			
	140.4	36	2.4	6.41	2.8			
	156.8	33	2.5	5.74	2.8			
	174.4	29	3.0	5.16	2.8			
	194.4	26	2.9	4.63	2.8			
	214.8	24	2.9	4.19	2.8			
	236.2	22	2.9	3.81	2.8			
	261.6	19	2.9	3.44	2.8			
	50.6	100	0.9	27.66	2.8	A/F 202 G 80M4B / 80M4C	13	116
	56.4	89	1.0	24.83	2.8			
	62.4	81	1.1	22.44	2.8			
	68.8	73	1.2	20.35	2.8			
	75.1	67	1.3	18.63	2.8			
	88.9	57	1.5	15.74	2.8			
	103.2	49	1.7	13.56	2.8			
	115.8	44	2.0	12.09	2.8			
	122.7	41	2.1	11.41	2.8			
	129.0	39	2.2	10.85	2.8			
	142.7	35	2.4	9.81	2.8			
	160.0	32	2.8	8.75	2.8			
	179.3	28	2.9	7.81	2.8			
	60.3	81	0.8	46.41	2.8	A/F 202 G 71M2B	12	116
	67.7	72	0.9	41.38	2.8			
	75.3	65	1.0	37.17	2.8			
	82.4	59	1.1	34.00	2.8			
	91.7	53	1.3	30.55	2.8			
	101.2	48	1.4	27.66	2.8			
	112.8	43	1.6	24.83	2.8			
	124.8	39	1.8	22.44	2.8			
137.6	36	1.8	20.35	2.8				
150.3	33	2.0	18.63	2.8				
177.9	27	2.3	15.74	2.8				
206.5	24	2.7	13.56	2.8				
106.1	46	0.9	26.38	2.5	A/F 202 71M2B	10	114	
116.8	42	1.0	23.98	2.5				
127.9	38	1.1	21.90	2.5				
131.1	37	1.1	21.36	2.5				
145.6	34	1.2	19.23	2.5				
161.2	30	1.4	17.37	2.5				
177.8	28	1.5	15.75	2.5				
194.2	25	1.5	14.42	2.5				
211.6	23	1.5	13.23	2.5				
243.1	20	1.9	11.52	2.5				
279.2	18	2.4	10.03	2.5				
313.5	16	2.7	8.93	2.5				
348.7	14	3.0	8.03	2.5				



P ₁ [kW]	n ₂ [Min ⁻¹]	M ₂ [Nm]	f _B	i _{ges}	FR (a) [kN]	Tip / Type / Typ / Tipo / Type / Tipo IE2 / IE3	 Kg ~	 mm			
0.75	4.0	1693	1.1	222.59	18.0	A/F 503 90S6B / 90L6C	57	134			
	4.6	1482	1.3	194.86	18.0						
	5.0	1361	1.4	178.98	18.0						
	5.5	1234	1.5	162.21	18.0						
	5.8	1175	1.6	154.52	18.0						
	6.3	1080	1.8	142.00	18.0						
	7.2	945	2.0	124.25	18.0						
	8.0	856	2.2	112.61	18.0						
	9.2	744	2.5	97.80	18.0						
	10.5	649	2.9	85.33	18.0						
	6.3	1070	1.7	222.59	18.0				A/F 503 80M4C / 80M4D	52	134
	7.2	937	1.9	194.86	18.0						
	7.8	861	2.1	178.98	18.0						
	8.6	780	2.3	162.21	18.0						
	9.1	743	2.4	154.52	18.0						
	9.9	683	2.6	142.00	18.0						
	11.3	598	3.0	124.25	18.0						
	12.6	512	2.7	222.59	18.0	A/F 503 80M2B / 80M2C	52	134			
	6.0	1137	0.8	149.47	12.0	A/F 403 90S6B / 90L6C	40	130			
	6.6	1030	0.9	135.37	12.0						
	7.6	898	1.0	118.13	12.0						
	9.5	721	1.2	94.86	12.0						
	10.5	653	1.4	85.91	12.0						
	13.2	519	1.7	68.25	12.0						
	16.4	417	2.1	54.81	12.0						
	18.1	378	2.4	49.64	12.0						
	6.0	1128	0.8	234.50	12.0	A/F 403 80M4C / 80M4D	35	130			
	6.5	1034	0.8	215.01	12.0						
	7.5	895	0.9	186.14	12.0						
	8.2	820	1.0	170.55	12.0						
	9.4	719	1.2	149.47	12.0						
	10.3	651	1.3	135.37	12.0						
	11.9	568	1.5	118.13	12.0						
	14.8	456	1.9	94.86	12.0						
	16.3	413	2.1	85.91	12.0						
	20.5	328	2.6	68.25	12.0						
	10.5	615	1.0	267.75	12.0	A/F 403 80M2B / 80M2C	35	130			
	11.9	539	1.2	234.50	12.0						
	13.0	494	1.3	215.01	12.0						
	15.0	428	1.5	186.14	12.0						
	16.4	392	1.6	170.55	12.0						
	18.7	344	1.9	149.47	12.0						
	20.7	311	2.1	135.37	12.0						
	23.7	272	2.4	118.13	12.0						
	29.5	218	3.0	94.86	12.0						
	19.8	350	2.5	45.38	12.0	A/F 402 90S6B / 90L6C	40	130			
	22.7	307	2.9	39.72	12.0						
	24.7	281	3.0	36.44	12.0						
109.1	65	2.8	8.25	3.7	A/F 401 90S6B / 90L6C	26	128				
9.9	688	0.8	90.51	8.0	A/F 353 90S6B / 90L6C	31	126				
12.4	552	1.0	72.58	8.0							
15.3	446	1.2	58.68	8.0							
10.4	648	0.8	134.76	8.0	A/F 353 80M4C / 80M4D	26	126				
12.8	524	1.0	108.95	8.0							
15.5	435	1.1	90.51	8.0							
19.3	349	1.4	72.58	8.0							
23.9	282	1.8	58.68	8.0							
20.8	310	1.2	134.76	8.0	A/F 353 80M2B / 80M2C	26	126				
25.7	250	1.5	108.95	8.0							
30.9	208	1.8	90.51	8.0							
38.6	167	2.3	72.58	8.0							
47.7	135	2.8	58.68	8.0							

P_1 [kW]	n_2 [Min ⁻¹]	M_2 [Nm]	f_B	i_{ges}	FR (a) [kN]	Tip / Type / Typ / Tipo / Type / Tipo IE2 / IE3	 Kg ~	 mm			
0.75	15.8	440	1.2	56.95	8.0	A/F 352 90S6B / 90L6C	31	126			
	18.0	385	1.3	49.88	8.0						
	19.5	355	1.4	46.04	8.0						
	22.7	306	1.7	39.59	8.0						
	26.9	259	2.0	33.50	8.0						
	28.1	247	2.1	32.01	8.0						
	31.2	223	2.3	28.89	8.0						
	33.8	205	2.5	26.59	8.0						
	35.8	194	2.5	25.13	8.0						
	40.9	170	2.9	22.03	8.0						
	24.6	280	1.8	56.95	8.0				A/F 352 80M4C / 80M4D	26	126
	28.1	245	2.0	49.88	8.0						
	30.4	226	2.2	46.04	8.0						
	35.4	194	2.5	39.59	8.0						
	41.8	165	3.0	33.50	8.0						
	49.2	136	2.7	56.95	8.0	A/F 352 80M2B / 80M2C	26	126			
	105.9	67	1.6	8.50	2.5	A/F 351 90S6B / 90L6C	22	124			
	121.0	58	1.8	7.44	2.5						
	152.3	46	2.3	5.91	2.5						
	168.9	42	2.5	5.33	2.5						
	185.6	38	2.6	4.85	2.5						
	221.1	32	3.0	4.07	2.5						
	164.7	43	2.3	8.50	2.5				A/F 351 80M4C / 80M4D	17	124
	188.2	37	2.7	7.44	2.5						
	18.3	368	0.8	76.42	6.6	A/F 303 80M4C / 80M4D	21	122			
	22.7	296	1.0	61.63	6.6						
	24.5	263	0.9	114.42	6.6	A/F 303 80M2B / 80M2C	21	122			
	32.2	200	1.1	86.96	6.6						
	36.6	176	1.3	76.42	6.6						
	45.4	142	1.6	61.63	6.6						
	18.7	372	0.8	48.22	6.6						
	20.3	343	0.9	44.38	6.6	A/F 302 90S6B / 90L6C	26	122			
	23.5	296	1.0	38.33	6.6						
	26.0	267	1.1	34.62	6.6						
	29.1	239	1.2	30.91	6.6						
	32.2	216	1.4	27.92	6.6						
	34.0	204	1.3	26.45	6.6						
	38.3	181	1.5	23.49	6.6						
	42.2	165	1.6	21.33	6.6						
	46.7	149	1.8	19.29	6.6						
	55.5	125	2.1	16.21	6.6						
	65.2	107	2.5	13.81	6.6						
	75.0	93	2.8	12.00	6.6						
	122.6	57	3.0	7.34	6.6						
	25.4	270	1.0	55.03	6.6				A/F 302 80M4C / 80M4D	21	122
	29.0	237	1.2	48.22	6.6						
	31.5	218	1.3	44.38	6.6						
	36.5	188	1.5	38.33	6.6						
40.4	170	1.6	34.62	6.6							
45.3	152	1.8	30.91	6.6							
50.1	137	2.0	27.92	6.6							
52.9	130	2.0	26.45	6.6							
59.6	115	2.3	23.49	6.6							
65.6	105	2.4	21.33	6.6							
72.6	95	2.6	19.29	6.6							
50.9	131	1.6	55.03	6.6	A/F 302 80M2B / 80M2C	21	122				
58.1	115	1.9	48.22	6.6							
63.1	106	2.0	44.38	6.6							
73.0	91	2.3	38.33	6.6							
80.9	82	2.6	34.62	6.6							
90.6	74	2.9	30.91	6.6							

P ₁ [kW]	n ₂ [Min ⁻¹]	M ₂ [Nm]	f _B	i _{ges}	FR (a) [kN]	Tip / Type / Typ / Tipo / Type / Tipo IE2 / IE3	 Kg ~	 mm			
0.75	101.4	70	0.8	8.88	1.0	A/F 301 90S6B / 90L6C	20	120			
	115.7	61	0.9	7.78	1.0						
	145.6	48	1.1	6.18	1.0						
	161.3	44	1.2	5.58	1.0						
	177.2	40	1.2	5.08	1.0						
	210.8	33	1.4	4.27	1.0						
	246.6	29	1.7	3.65	1.0						
	284.8	25	1.7	3.16	1.0						
	326.1	22	1.5	2.76	0.9						
	347.5	20	1.6	2.59	0.9						
	441.2	16	1.6	2.04	0.8						
	612.2	12	2.3	1.47	0.8						
	157.7	45	1.2	8.88	1.0	A/F 301 80M4C / 80M4D	15	120			
	179.9	39	1.3	7.78	1.0						
	226.5	31	1.6	6.18	1.0						
	250.9	28	1.8	5.58	1.0						
	275.6	25	1.8	5.08	1.0						
	327.9	21	2.1	4.27	1.0						
	383.6	18	2.5	3.65	1.0						
	443.0	16	2.5	3.16	1.0						
	507.2	14	2.2	2.76	0.9						
	540.5	13	2.3	2.59	0.9						
	686.3	10	2.4	2.04	0.8						
	315.3	22	1.9	8.88	1.0	A/F 301 80M2B / 80M2C	15	120			
	359.9	19	2.0	7.78	1.0						
	453.1	15	2.5	6.18	1.0						
	501.8	14	2.8	5.58	1.0						
	551.2	13	2.7	5.08	1.0						
	26.2	257	0.8	53.41	5.5	A/F 253 80M4C / 80M4D	18	118			
	37.5	172	0.9	74.76	5.5	A/F 253 80M2B / 80M2C	18	118			
	42.1	153	1.0	66.56	5.5						
	52.4	123	1.2	53.41	5.5						
	27.0	258	0.8	33.38	5.5	A/F 252 90S6B / 90L6C	23	118			
	29.9	233	0.9	30.15	5.5						
	33.6	207	1.0	26.79	5.5						
	37.2	187	1.1	24.19	5.5						
	39.1	178	1.2	23.04	5.5						
	44.6	156	1.3	20.19	5.4						
	48.7	143	1.5	18.49	5.5						
	52.8	132	1.5	17.05	5.5						
	60.4	115	1.6	14.91	5.5						
	64.6	108	1.7	13.94	5.5						
	75.2	92	1.6	11.97	5.3						
	87.2	80	1.8	10.32	5.2						
	99.8	70	2.0	9.02	5.0						
	113.5	61	2.1	7.93	4.9						
	141.5	49	2.2	6.36	4.6						
	187.5	37	2.7	4.80	3.7						
	29.2	235	0.8	47.93	5.5				A/F 252 80M4C / 80M4D	18	118
	33.3	206	1.0	42.00	5.5						
	36.4	189	1.1	38.46	5.5						
	41.9	164	1.2	33.38	5.5						
	46.4	148	1.4	30.15	5.5						
	52.3	132	1.5	26.79	5.5						
	57.9	119	1.7	24.19	5.5						
	60.8	113	1.8	23.04	5.5						
	69.3	99	2.0	20.19	5.4						
	75.7	91	2.2	18.49	5.5						
	82.1	84	2.3	17.05	5.5						
	93.9	73	2.3	14.91	5.5						
	100.4	68	2.5	13.94	5.5						
	117.0	59	2.5	11.97	5.3						
	135.7	51	2.8	10.32	5.2						
	155.2	44	2.9	9.02	5.0						

P ₁ [kW]	n ₂ [Min ⁻¹]	M ₂ [Nm]	f _B	i _{ges}	FR (a) [kN]	Tip / Type / Typ / Tipo / Type / Tipo IE2 / IE3	 Kg ~	 mm	
0.75	58.4	114	1.3	47.93	5.5	A/F 252 80M2B / 80M2C	18	118	
	66.7	100	1.5	42.00	5.5				
	72.8	92	1.7	38.46	5.5				
	83.9	80	1.9	33.38	5.5				
	92.9	72	2.1	30.15	5.5				
	104.5	64	2.4	26.79	5.5				
	115.8	58	2.6	24.19	5.5				
	121.5	55	2.8	23.04	5.5				
	78.9	88	1.0	11.41	2.8	A/F 202 G 90S6B / 90L6C	18	116	
	82.9	84	1.1	10.85	2.8				
	91.7	76	1.2	9.81	2.8				
	102.9	68	1.4	8.75	2.8				
	115.2	60	1.4	7.81	2.8				
	127.8	54	1.6	7.04	2.8				
	140.4	49	1.7	6.41	2.8				
	156.8	44	1.8	5.74	2.8				
	174.4	40	2.2	5.16	2.8				
	194.4	36	2.1	4.63	2.8				
	214.8	32	2.1	4.19	2.8				
	236.2	29	2.1	3.81	2.8				
	261.6	27	2.1	3.44	2.8				
	277.8	25	2.3	3.24	2.8				
	305.1	23	2.3	2.95	2.8				
	328.5	21	2.3	2.74	2.8				
	358.6	19	2.3	2.51	2.8				
	389.6	18	2.5	2.31	2.8				
	56.4	122	0.8	24.83	2.8	A/F 202 G 80M4C / 80M4D	13	116	
	62.4	110	0.8	22.44	2.8				
	68.8	100	0.9	20.35	2.8				
	75.1	91	0.9	18.63	2.8				
	88.9	77	1.1	15.74	2.8				
	103.2	67	1.3	13.56	2.8				
	115.8	59	1.5	12.09	2.8				
	122.7	56	1.5	11.41	2.8				
	129.0	53	1.6	10.85	2.8				
	142.7	48	1.8	9.81	2.8				
	160.0	43	2.0	8.75	2.8				
	179.3	38	2.1	7.81	2.8				
	198.9	35	2.4	7.04	2.8				
	218.4	31	2.6	6.41	2.8				
	243.9	28	2.7	5.74	2.8				
	101.2	66	1.1	27.66	2.8	A/F 202 G 80M2B / 80M2C	13	116	
112.8	59	1.2	24.83	2.8					
124.8	53	1.3	22.44	2.8					
137.6	48	1.3	20.35	2.8					
150.3	44	1.4	18.63	2.8					
177.9	37	1.7	15.74	2.8					
206.5	32	2.0	13.56	2.8					
231.6	29	2.3	12.09	2.8					
245.4	27	2.4	11.41	2.8					
258.1	26	2.5	10.85	2.8					
285.4	23	2.8	9.81	2.8					
1.10	3.7	2707	1.4	242.67	22.0	A/F 603 90L6C / 90L6D	84	138	
	4.2	2405	1.5	215.56	22.0				
	4.6	2167	1.7	194.31	22.0				
	5.0	2020	1.8	181.13	22.0				
	5.6	1795	2.0	160.90	22.0				
	6.3	1601	2.3	143.57	22.0				
	5.8	1712	2.1	242.67	22.0	A/F 603 90L4B / 90L4C	84	138	
	6.5	1520	2.3	215.56	22.0				
	7.2	1371	2.6	194.31	22.0				
	7.7	1278	2.7	181.13	22.0				



P ₁ [kW]	n ₂ [Min ⁻¹]	M ₂ [Nm]	f _B	i _{ges}	FR (a) [kN]	Tip / Type / Typ / Tipo / Type / Tipo IE2 / IE3	 Kg ~	 mm			
1.10	4.0	2483	0.8	222.59	18.0	A/F 503 90L6C / 90L6D	57	134			
	4.6	2174	0.9	194.86	18.0						
	5.0	1996	0.9	178.98	18.0						
	5.5	1809	1.0	162.21	18.0						
	5.8	1724	1.1	154.52	18.0						
	6.3	1584	1.2	142.00	18.0						
	7.2	1386	1.4	124.25	18.0						
	8.0	1256	1.5	112.61	18.0						
	9.2	1091	1.7	97.80	18.0						
	10.5	952	2.0	85.33	18.0						
	11.4	877	2.2	78.64	18.0						
	12.6	795	2.4	71.27	18.0						
	16.0	627	2.7	56.21	18.0						
	6.3	1570	1.1	222.59	18.0				A/F 503 90L4B / 90L4C	57	134
	7.2	1374	1.3	194.86	18.0						
	7.8	1262	1.4	178.98	18.0						
	8.6	1144	1.6	162.21	18.0						
	9.1	1090	1.7	154.52	18.0						
	9.9	1002	1.8	142.00	18.0						
	11.3	876	2.1	124.25	18.0						
	12.4	794	2.3	112.61	18.0						
	14.3	690	2.6	97.80	18.0						
	16.4	602	3.0	85.33	18.0						
	12.6	750	1.8	222.59	18.0	A/F 503 80M2C / 80M2D	52	134			
	14.4	657	2.1	194.86	18.0						
	15.6	603	2.3	178.98	18.0						
	17.3	547	2.5	162.21	18.0						
	18.1	521	2.6	154.52	18.0						
	19.7	479	2.9	142.00	18.0						
	18.5	552	3.0	48.77	18.0	A/F 502 90L6C / 90L6D	57	134			
	9.5	1058	0.8	94.86	12.0	A/F 403 90L6C / 90L6D	40	130			
	10.5	958	0.9	85.91	12.0						
	13.2	761	1.2	68.25	12.0						
	16.4	611	1.5	54.81	12.0						
	18.1	554	1.6	49.64	12.0						
	9.4	1054	0.8	149.47	12.0	A/F 403 90L4B / 90L4C	40	130			
	10.3	955	0.9	135.37	12.0						
	11.9	833	1.0	118.13	12.0						
	14.8	669	1.3	94.86	12.0						
	16.3	606	1.4	85.91	12.0						
	20.5	481	1.8	68.25	12.0						
	25.5	387	2.2	54.81	12.0						
	28.2	350	2.4	49.64	12.0						
	11.9	791	0.8	234.50	12.0	A/F 403 80M2C / 80M2D	35	130			
	13.0	725	0.9	215.01	12.0						
15.0	628	1.0	186.14	12.0							
16.4	575	1.1	170.55	12.0							
18.7	504	1.3	149.47	12.0							
20.7	456	1.4	135.37	12.0							
23.7	398	1.6	118.13	12.0							
29.5	320	2.0	94.86	12.0							
32.6	290	2.2	85.91	12.0							
41.0	230	2.8	68.25	12.0							
19.8	514	1.7	45.38	12.0	A/F 402 90L6C / 90L6D	40	130				
22.7	450	2.0	39.72	12.0							
24.7	413	2.0	36.44	12.0							
28.6	357	2.5	31.50	12.0							
31.2	327	2.6	28.89	12.0							
30.9	327	2.6	45.38	12.0	A/F 402 90L4B / 90L4C	40	130				
35.2	286	3.0	39.72	12.0							
38.4	262	3.0	36.44	12.0							
109.1	95	1.9	8.25	3.7	A/F 401 90L6C / 90L6D	26	128				
124.7	83	2.2	7.22	3.7							
157.1	66	2.7	5.73	3.7							
174.1	59	3.0	5.17	3.7							



P_1 [kW]	n_2 [Min ⁻¹]	M_2 [Nm]	f_B	i_{ges}	FR (a) [kN]	Tip / Type / Typ / Tipo / Type / Tipo IE2 / IE3	 ~	
1.10	169.7	61	2.8	8.25	3.7	A/F 401 90L4B / 90L4C	26	128
	15.3	655	0.8	58.68	8.0	A/F 353 90L6C / 90L6D	31	126
	15.5 19.3 23.9	638 512 414	0.8 1.0 1.2	90.51 72.58 58.68	8.0 8.0 8.0	A/F 353 90L4B / 90L4C	31	126
	20.8 25.7 30.9 38.6 47.7	454 367 305 245 198	0.8 1.0 1.2 1.6 1.9	134.76 108.95 90.51 72.58 58.68	8.0 8.0 8.0 8.0 8.0	A/F 353 80M2C / 80M2D	26	126
	15.8 18.0 19.5 22.7 26.9 28.1 31.2 33.8 35.8 40.9 44.3 49.2 53.3 62.0	645 565 521 448 379 363 327 301 285 249 230 207 191 164	0.8 0.9 1.0 1.1 1.4 1.4 1.6 1.7 1.7 2.0 2.1 2.3 2.5 2.7	56.95 49.88 46.04 39.59 33.50 32.01 28.89 26.59 25.13 22.03 20.31 18.30 16.88 14.52	8.0 8.0 8.0 8.0 8.0 8.0 8.0 8.0 8.0 8.0 8.0 8.0 8.0 8.0	A/F 352 90L6C / 90L6D	31	126
	24.6 28.1 30.4 35.4 41.8 43.7 48.5 52.7 55.7 63.5	410 359 332 285 241 231 208 192 181 159	1.2 1.4 1.5 1.7 2.0 2.1 2.4 2.6 2.6 3.0	56.95 49.88 46.04 39.59 33.50 32.01 28.89 26.59 25.13 22.03	8.0 8.0 8.0 8.0 8.0 8.0 8.0 8.0 8.0 8.0	A/F 352 90L4B / 90L4C	31	126
	49.2 56.1 60.8 70.7	199 174 161 138	1.9 2.1 2.3 2.7	56.95 49.88 46.04 39.59	8.0 8.0 8.0 8.0	A/F 352 80M2C / 80M2D	26	126
	105.9 121.0 152.3 168.9 185.6 221.1 240.0 279.5 414.7 692.3	98 86 68 61 56 47 43 37 25 15	1.1 1.2 1.5 1.7 1.8 2.0 2.2 2.3 2.5 2.8	8.50 7.44 5.91 5.33 4.85 4.07 3.75 3.22 2.17 1.30	2.5 2.5 2.5 2.5 2.5 2.5 2.5 2.5 2.5 2.5	A/F 351 90L6C / 90L6D	22	124
	164.7 188.2 236.9 262.7 288.7 344.0	63 55 43 39 36 30	1.6 1.8 2.3 2.6 2.7 3.0	8.50 7.44 5.91 5.33 4.85 4.07	2.5 2.5 2.5 2.5 2.5 2.5	A/F 351 90L4B / 90L4C	22	124
	329.4 376.3	31 27	2.5 2.8	8.50 7.44	2.5 2.5	A/F 351 80M2C / 80M2D	17	124
	32.2 36.6 45.4	293 258 208	0.8 0.9 1.1	86.96 76.42 61.63	6.6 6.6 6.6	A/F 303 80M2C / 80M2D	21	122



P₁ [kW]	n₂ [Min ⁻¹]	M₂ [Nm]	f_B	i_{ges}	FR (a) [kN]	Tip / Type / Typ / Tipo / Type / Tipo IE2 / IE3	kg ~	mm			
1.10	29.1	350	0.8	30.91	6.6	A/F 302 90L6C / 90L6D	26	122			
	32.2	316	0.9	27.92	6.6						
	34.0	300	0.9	26.45	6.6						
	38.3	266	1.0	23.49	6.6						
	42.2	242	1.1	21.33	6.6						
	46.7	218	1.2	19.29	6.6						
	55.5	184	1.4	16.21	6.5						
	65.2	156	1.7	13.81	6.3						
	75.0	136	1.9	12.00	6.1						
	85.7	119	2.1	10.50	5.8						
	98.8	103	2.1	9.11	5.6						
	122.6	83	2.0	7.34	5.3						
	161.3	63	2.7	5.58	4.8						
	29.0	347	0.8	48.22	6.6				A/F 302 90L4B / 90L4C	26	122
	31.5	320	0.9	44.38	6.6						
	36.5	276	1.0	38.33	6.6						
	40.4	249	1.1	34.62	6.6						
	45.3	223	1.3	30.91	6.6						
	50.1	201	1.4	27.92	6.6						
	52.9	191	1.4	26.45	6.6						
	59.6	169	1.5	23.49	6.6						
	65.6	154	1.6	21.33	6.6						
	72.6	139	1.8	19.29	6.6						
	86.4	117	2.1	16.21	6.5						
	101.4	99	2.5	13.81	6.3						
	116.7	86	2.9	12.00	6.1						
	190.7	53	3.0	7.34	5.3						
	50.9	192	1.1	55.03	6.6	A/F 302 80M2C / 80M2D	21	122			
	58.1	168	1.3	48.22	6.6						
	63.1	155	1.4	44.38	6.6						
	73.0	134	1.6	38.33	6.6						
	80.9	121	1.8	34.62	6.6						
	90.6	108	2.0	30.91	6.6						
	100.3	98	2.2	27.92	6.6						
	105.9	92	2.1	26.45	6.6						
	119.2	82	2.4	23.49	6.6						
	131.3	75	2.5	21.33	6.6						
	145.2	67	2.8	19.29	6.6						
	161.3	64	0.8	5.58	0.9				A/F 301 90L6C / 90L6D	20	120
	177.2	58	0.8	5.08	0.9						
	210.8	49	1.0	4.27	0.9						
	246.6	42	1.1	3.65	0.8						
	284.8	36	1.2	3.16	0.8						
	326.1	32	1.0	2.76	0.8						
	347.5	30	1.1	2.59	0.8						
	441.2	23	1.1	2.04	0.7						
	612.2	17	1.6	1.47	0.7						
	157.7	65	0.8	8.88	1.0	A/F 301 90L4B / 90L4C	20	120			
179.9	57	0.9	7.78	1.0							
226.5	45	1.1	6.18	0.9							
250.9	41	1.2	5.58	0.9							
275.6	37	1.2	5.08	0.9							
327.9	31	1.4	4.27	0.9							
383.6	27	1.7	3.65	0.8							
443.0	23	1.7	3.16	0.8							
507.2	20	1.5	2.76	0.8							
540.5	19	1.6	2.59	0.8							
686.3	15	1.7	2.04	0.7							
952.4	11	2.3	1.47	0.7							
315.3	32	1.3	8.88	1.0	A/F 301 80M2C / 80M2D				15	120	
359.9	28	1.3	7.78	1.0							
453.1	22	1.7	6.18	0.9							
501.8	20	1.9	5.58	0.9							
551.2	18	1.9	5.08	0.9							
655.7	15	2.2	4.27	0.9							
767.1	13	2.6	3.65	0.8							
886.1	11	2.7	3.16	0.8							
1014.5	10	2.3	2.76	0.8							
1081.1	9	2.4	2.59	0.8							
1372.5	7	2.6	2.04	0.7							



P_1 [kW]	n_2 [Min ⁻¹]	M_2 [Nm]	f_B	i_{ges}	FR (a) [kN]	Tip / Type / Typ / Tipo / Type / Tipo IE2 / IE3	~	
1.10	52.4	180	0.8	53.41	5.5	A/F 253 80M2C / 80M2D	18	118
	37.2	274	0.8	24.19	5.1	A/F 252 90L6C / 90L6D	23	118
	39.1	261	0.8	23.04	5.0			
	44.6	229	0.9	20.19	5.0			
	48.7	209	1.0	18.49	4.9			
	52.8	193	1.0	17.05	4.8			
	60.4	169	1.1	14.91	4.7			
	64.6	158	1.1	13.94	4.7			
	75.2	136	1.1	11.97	4.5			
	87.2	117	1.3	10.32	4.4			
	99.8	102	1.3	9.02	4.3			
	113.5	90	1.5	7.93	4.2			
	141.5	72	1.5	6.36	3.9			
	187.5	54	1.8	4.80	3.7			
	41.9	240	0.8	33.38	5.5	A/F 252 90L4B / 90L4C	23	118
	46.4	217	0.9	30.15	5.1			
	52.3	193	1.0	26.79	5.1			
	57.9	174	1.1	24.19	5.1			
	60.8	166	1.2	23.04	5.0			
	69.3	145	1.4	20.19	5.0			
	75.7	133	1.5	18.49	4.9			
	82.1	123	1.5	17.05	4.8			
	93.9	107	1.6	14.91	4.7			
	100.4	100	1.7	13.94	4.7			
	117.0	86	1.7	11.97	4.5			
	135.7	74	1.9	10.32	4.4			
	155.2	65	2.0	9.02	4.3			
	176.5	57	2.2	7.93	4.2			
	220.1	46	2.3	6.36	3.9			
	291.7	35	2.7	4.80	3.7			
	58.4	167	0.9	47.93	5.5	A/F 252 80M2C / 80M2D	18	118
	66.7	147	1.0	42.00	5.5			
	72.8	134	1.1	38.46	5.5			
	83.9	117	1.3	33.38	5.5			
	92.9	105	1.4	30.15	5.1			
	104.5	94	1.6	26.79	5.1			
	115.8	85	1.8	24.19	5.1			
	121.5	80	1.9	23.04	5.0			
	138.7	71	2.2	20.19	5.0			
	151.4	65	2.4	18.49	4.9			
	164.2	60	2.4	17.05	4.8			
187.8	52	2.5	14.91	4.7				
200.9	49	2.7	13.94	4.7				
233.9	42	2.6	11.97	4.5				
271.3	36	3.0	10.32	4.4				
91.7	111	0.8	9.81	2.8	A/F 202 G 90L6C / 90L6D	18	116	
102.9	99	0.9	8.75	2.8				
115.2	88	1.0	7.81	2.8				
127.8	80	1.1	7.04	2.8				
140.4	73	1.2	6.41	2.8				
156.8	65	1.2	5.74	2.8				
174.4	58	1.5	5.16	2.8				
194.4	52	1.4	4.63	2.8				
214.8	47	1.4	4.19	2.8				
236.2	43	1.4	3.81	2.8				
261.6	39	1.5	3.44	2.8				
277.8	37	1.5	3.24	2.8				
305.1	33	1.6	2.95	2.8				
328.5	31	1.6	2.74	2.8				
358.6	28	1.6	2.51	2.8				
389.6	26	1.7	2.31	2.8				



P₁ [kW]	n₂ [Min ⁻¹]	M₂ [Nm]	f_B	i_{ges}	FR (a) [kN]	Tip / Type / Typ / Tipo / Type / Tipo IE2 / IE3	Kg ~	mm
1.10	122.7	82	1.0	11.41	2.8	A/F 202 G 90L4B / 90L4C	18	116
	129.0	78	1.1	10.85	2.8			
	142.7	71	1.2	9.81	2.8			
	160.0	63	1.4	8.75	2.8			
	179.3	56	1.5	7.81	2.8			
	198.9	51	1.6	7.04	2.8			
	218.4	46	1.8	6.41	2.8			
	243.9	41	1.9	5.74	2.8			
	271.3	37	2.2	5.16	2.8			
	302.4	33	2.2	4.63	2.8			
	334.1	30	2.2	4.19	2.8			
	367.5	27	2.1	3.81	2.8			
	407.0	25	2.2	3.44	2.8			
	432.1	23	2.3	3.24	2.8			
	474.6	21	2.4	2.95	2.8			
	510.9	20	2.3	2.74	2.8			
	557.8	18	2.4	2.51	2.8			
	606.1	17	2.6	2.31	2.8			
	112.8	87	0.8	24.83	2.8	A/F 202 G 80M2C / 80M2D	13	116
	124.8	78	0.9	22.44	2.8			
	137.6	71	0.9	20.35	2.8			
	150.3	65	1.0	18.63	2.8			
	177.9	55	1.2	15.74	2.8			
	206.5	47	1.4	13.56	2.8			
	231.6	42	1.6	12.09	2.8			
	245.4	40	1.6	11.41	2.8			
	258.1	38	1.7	10.85	2.8			
	285.4	34	1.9	9.81	2.8			
	320.0	31	2.2	8.75	2.8			
	358.5	27	2.3	7.81	2.8			
	397.7	25	2.5	7.04	2.8			
	436.8	22	2.8	6.41	2.8			
	487.8	20	2.9	5.74	2.8			
	1.50	3.5	3957	1.3	260.15	30.0	A/F 703 100L6C / 100L6D	123
3.9		3519	1.5	231.34	30.0			
4.3		3161	1.7	207.78	30.0			
4.7		2883	1.8	189.54	30.0			
5.2		2633	2.0	173.11	30.0			
5.8		2365	2.2	155.48	30.0			
6.2		2205	2.4	144.94	30.0			
7.0		1952	2.7	128.35	30.0			
7.6		1806	2.9	118.75	30.0			
3.7		3691	1.0	242.67	22.0	A/F 603 100L6C / 100L6D		
4.2		3279	1.1	215.56	22.0			
4.6		2956	1.2	194.31	22.0			
5.0		2755	1.3	181.13	22.0			
5.6		2447	1.5	160.90	22.0			
6.3		2184	1.7	143.57	22.0			
6.7		2042	1.8	134.25	22.0			
7.4		1841	2.0	121.02	22.0			
9.0		1524	2.4	100.21	22.0			
9.6		1424	2.6	93.60	22.0			
10.7		1283	2.9	84.37	22.0			
11.3		1217	3.0	79.98	22.0			
5.8		2334	1.5	242.67	22.0	A/F 603 90L4C / 90L4D	84	138
6.5		2073	1.7	215.56	22.0			
7.2		1869	1.9	194.31	22.0			
7.7		1742	2.0	181.13	22.0			
8.7		1548	2.3	160.90	22.0			
9.8		1381	2.5	143.57	22.0			
11.5		1116	2.5	242.67	22.0	A/F 603 90L2B / 90L2C	84	138
13.0	991	2.7	215.56	22.0				
14.4	893	3.0	194.31	22.0				

P ₁ [kW]	n ₂ [Min ⁻¹]	M ₂ [Nm]	f _B	i _{ges}	FR (a) [kN]	Tip / Type / Typ / Tipo / Type / Tipo IE2 / IE3	 Kg ~	 mm			
1.50	5.8	2350	0.8	154.52	18.0	A/F 503 100L6C / 100L6D	67	134			
	6.3	2160	0.9	142.00	18.0						
	7.2	1890	1.0	124.25	18.0						
	8.0	1713	1.1	112.61	18.0						
	9.2	1488	1.3	97.80	18.0						
	10.5	1298	1.5	85.33	18.0						
	11.4	1196	1.6	78.64	18.0						
	12.6	1084	1.7	71.27	18.0						
	16.0	855	2.0	56.21	18.0						
	6.3	2141	0.8	222.59	18.0				A/F 503 90L4C / 90L4D	57	134
	7.2	1874	1.0	194.86	18.0						
	7.8	1721	1.0	178.98	18.0						
	8.6	1560	1.2	162.21	18.0						
	9.1	1486	1.2	154.52	18.0						
	9.9	1366	1.3	142.00	18.0						
	11.3	1195	1.5	124.25	18.0						
	12.4	1083	1.7	112.61	18.0						
	14.3	941	1.9	97.80	18.0						
	16.4	821	2.2	85.33	18.0						
	17.8	756	2.4	78.64	18.0						
	19.6	685	2.6	71.27	18.0						
	24.9	541	3.0	56.21	18.0						
	12.6	1023	1.3	222.59	18.0	A/F 503 90L2B / 90L2C	57	134			
	14.4	896	1.5	194.86	18.0						
	15.6	823	1.7	178.98	18.0						
	17.3	746	1.8	162.21	18.0						
	18.1	710	1.9	154.52	18.0						
	19.7	653	2.1	142.00	18.0						
	22.5	571	2.4	124.25	18.0						
	24.9	518	2.6	112.61	18.0						
	28.6	450	3.0	97.80	18.0						
	18.5	753	2.2	48.77	18.0				A/F 502 100L6C / 100L6D	67	134
	20.8	669	2.5	43.32	18.0						
	23.0	606	2.8	39.21	18.0						
	105.1	134	2.7	8.56	4.0	A/F 502 100L6C / 100L6D	42	134			
	13.2	1038	0.9	68.25	12.0	A/F 403 100L6C / 100L6D	50	130			
	16.4	834	1.1	54.81	12.0						
	18.1	755	1.2	49.64	12.0						
	14.8	912	0.9	94.86	12.0	A/F 403 90L4C / 90L4D	40	130			
	16.3	826	1.0	85.91	12.0						
	20.5	656	1.3	68.25	12.0						
	25.5	527	1.6	54.81	12.0						
	28.2	477	1.8	49.64	12.0						
	15.0	856	0.8	186.14	12.0				A/F 403 90L2B / 90L2C	40	130
	16.4	784	0.8	170.55	12.0						
	18.7	687	0.9	149.47	12.0						
	20.7	622	1.0	135.37	12.0						
	23.7	543	1.2	118.13	12.0						
29.5	436	1.5	94.86	12.0							
32.6	395	1.6	85.91	12.0							
41.0	314	2.1	68.25	12.0							
51.1	252	2.6	54.81	12.0							
56.4	228	2.8	49.64	12.0							
19.8	701	1.3	45.38	12.0	A/F 402 100L6C / 100L6D	50	130				
22.7	613	1.5	39.72	12.0							
24.7	563	1.5	36.44	12.0							
28.6	486	1.8	31.50	12.0							
31.2	446	1.9	28.89	12.0							
35.6	391	2.3	25.30	12.0							
39.3	354	2.5	22.91	12.0							
45.1	308	2.9	19.94	12.0							
30.9	446	1.9	45.38	12.0				A/F 402 90L4C / 90L4D	40	130	
35.2	390	2.2	39.72	12.0							
38.4	358	2.2	36.44	12.0							
44.4	309	2.7	31.50	12.0							
48.5	284	2.8	28.89	12.0							

P_1 [kW]	n_2 [Min ⁻¹]	M_2 [Nm]	f_B	i_{ges}	FR (a) [kN]	Tip / Type / Typ / Tipo / Type / Tipo IE2 / IE3	 Kg ~	 mm
1.50	61.7	216	3.0	45.38	12.0	A/F 402 90L2B / 90L2C	40	130
	109.1	129	1.4	8.25	3.7	A/F 401 100L6C / 100L6D	36	128
	124.7	113	1.6	7.22	3.7			
	157.1	90	2.0	5.73	3.7			
	174.1	81	2.2	5.17	3.7			
	191.9	74	2.3	4.69	3.7			
	229.0	62	2.6	3.93	3.7			
	247.9	57	2.8	3.63	3.7			
	289.4	49	2.8	3.11	3.7			
	169.7	83	2.1	8.25	3.7	A/F 401 90L4C / 90L4D	26	128
	193.9	72	2.3	7.22	3.7	A/F 353 90L4C / 90L4D	31	126
	244.3	57	3.0	5.73	3.7			
	23.9	564	0.9	58.68	8.0			
	25.7	501	0.8	108.95	8.0	A/F 353 90L2B / 90L2C	31	126
	30.9	416	0.9	90.51	8.0			
	38.6	334	1.1	72.58	8.0			
	47.7	270	1.4	58.68	8.0			
	22.7	611	0.8	39.59	8.0			
	28.1	494	1.0	32.01	8.0			
	31.2	446	1.2	28.89	8.0			
	33.8	411	1.3	26.59	8.0			
	35.8	388	1.3	25.13	8.0			
	40.9	340	1.5	22.03	8.0			
	44.3	314	1.5	20.31	8.0			
	49.2	283	1.7	18.30	8.0			
	53.3	261	1.8	16.88	8.0			
	62.0	224	2.0	14.52	8.0			
	76.7	181	2.3	11.74	8.0			
	92.3	151	2.6	9.75	8.0			
	103.1	135	2.6	8.73	8.0			
	127.5	109	2.8	7.06	8.0			
	153.6	90	3.0	5.86	8.0			
	24.6	559	0.9	56.95	8.0	A/F 352 90L4C / 90L4D	31	126
	28.1	490	1.0	49.88	8.0			
	30.4	452	1.1	46.04	8.0			
	35.4	389	1.3	39.59	8.0			
	41.8	329	1.5	33.50	8.0			
	43.7	314	1.6	32.01	8.0			
	48.5	284	1.7	28.89	8.0			
	52.7	261	1.9	26.59	8.0			
	55.7	247	1.9	25.13	8.0			
	63.5	216	2.2	22.03	8.0			
	68.9	200	2.3	20.31	8.0			
	76.5	180	2.6	18.30	8.0			
	82.9	166	2.7	16.88	8.0			
	96.4	143	3.0	14.52	8.0			
	49.2	271	1.4	56.95	8.0	A/F 352 90L2B / 90L2C	31	126
	56.1	238	1.6	49.88	8.0			
60.8	219	1.7	46.04	8.0				
70.7	189	2.0	39.59	8.0				
83.6	160	2.3	33.50	8.0				
87.5	153	2.4	32.01	8.0				
96.9	138	2.7	28.89	8.0				
105.3	127	2.9	26.59	8.0				
111.4	120	3.0	25.13	8.0				
152.3	93	1.1	5.91	2.5	A/F 351 100L6C / 100L6D	32	124	
168.9	84	1.3	5.33	2.4				
185.6	76	1.3	4.85	2.4				
221.1	64	1.5	4.07	2.3				
240.0	59	1.6	3.75	2.2				
279.5	50	1.7	3.22	2.1				
343.5	41	1.8	2.62	1.9				
414.7	34	1.9	2.17	1.9				
620.7	23	2.8	1.45	1.6				
692.3	20	2.1	1.30	1.6				



P_1 [kW]	n_2 [Min ⁻¹]	M_2 [Nm]	f_B	i_{ges}	FR (a) [kN]	Tip / Type / Typ / Tipo / Type / Tipo IE2 / IE3	 ~	
1.50	164.7	85	1.2	8.50	2.5	A/F 351 90L4C / 90L4D	22	124
	188.2	75	1.3	7.44	2.5			
	236.9	59	1.7	5.91	2.5			
	262.7	53	1.9	5.33	2.4			
	288.7	49	2.0	4.85	2.4			
	344.0	41	2.2	4.07	2.3			
	373.3	38	2.4	3.75	2.2			
	434.8	32	2.5	3.22	2.1			
	645.2	22	2.8	2.17	1.9			
	329.4	42	1.8	8.50	2.5	A/F 351 90L2B / 90L2C	22	124
	376.3	37	2.1	7.44	2.5			
	473.8	29	2.6	5.91	2.5			
	525.3	26	2.9	5.33	2.4			
	577.3	24	3.0	4.85	2.4			
	45.4	283	0.8	61.63	6.6	A/F 303 90L2B / 90L2C	26	122
	42.2	329	0.8	21.33	6.5	A/F 302 100L6C / 100L6D	36	122
	46.7	298	0.9	19.29	6.4			
	55.5	250	1.0	16.21	6.2			
	65.2	213	1.2	13.81	6.0			
	75.0	185	1.4	12.00	5.8			
	85.7	162	1.6	10.50	5.6			
	98.8	141	1.6	9.11	5.4			
	122.6	113	1.5	7.34	5.2			
	161.3	86	1.9	5.58	4.8			
	40.4	340	0.8	34.62	6.6			
	45.3	304	0.9	30.91	6.6			
	50.1	274	1.0	27.92	6.6			
	52.9	260	1.0	26.45	6.6			
	59.6	231	1.1	23.49	6.6			
	65.6	210	1.2	21.33	6.5			
	72.6	189	1.3	19.29	6.4			
	86.4	159	1.6	16.21	6.2			
	101.4	136	1.8	13.81	6.0			
	116.7	118	2.1	12.00	5.8			
	133.3	103	2.3	10.50	5.6			
	153.7	89	2.3	9.11	5.4			
	190.7	72	2.2	7.34	5.2			
	250.9	55	2.9	5.58	4.8			
	50.9	262	0.8	55.03	6.6	A/F 302 90L2B / 90L2C	26	122
	58.1	230	0.9	48.22	6.6			
	63.1	211	1.0	44.38	6.6			
	73.0	183	1.2	38.33	6.6			
	80.9	165	1.3	34.62	6.6			
	90.6	147	1.4	30.91	6.6			
	100.3	133	1.6	27.92	6.6			
105.9	126	1.6	26.45	6.6				
119.2	112	1.8	23.49	6.6				
131.3	102	1.9	21.33	6.5				
145.2	92	2.1	19.29	6.4				
172.7	77	2.5	16.21	6.2				
202.8	66	2.9	13.81	6.0				
226.5	62	0.8	6.18	0.9	A/F 301 90L4C / 90L4D			
250.9	56	0.9	5.58	0.9				
275.6	51	0.9	5.08	0.8				
327.9	43	1.1	4.27	0.8				
383.6	37	1.2	3.65	0.8				
443.0	32	1.3	3.16	0.8				
507.2	28	1.1	2.76	0.8				
540.5	26	1.2	2.59	0.7				
686.3	20	1.2	2.04	0.7				
952.4	15	1.7	1.47	0.6				



P_1 [kW]	n_2 [Min ⁻¹]	M_2 [Nm]	f_B	i_{ges}	FR (a) [kN]	Tip / Type / Typ / Tipo / Type / Tipo IE2 / IE3	 Kg ~	 mm			
1.50	315.3	44	1.0	8.88	0.9	A/F 301 90L2B / 90L2C	20	120			
	359.9	38	1.0	7.78	0.9						
	453.1	31	1.2	6.18	0.9						
	501.8	28	1.4	5.58	0.9						
	551.2	25	1.4	5.08	0.8						
	655.7	21	1.6	4.27	0.8						
	767.1	18	1.9	3.65	0.8						
	886.1	16	1.9	3.16	0.8						
	1014.5	14	1.7	2.76	0.8						
	1081.1	13	1.8	2.59	0.7						
	1372.5	10	1.9	2.04	0.7						
	1904.8	7	2.6	1.47	0.6						
	52.8	263	0.8	17.05	4.4				A/F 252 100L6C / 100L6D	33	118
	60.4	230	0.8	14.91	4.3						
	64.6	215	0.8	13.94	4.3						
	75.2	185	0.8	11.97	4.2						
	87.2	159	0.9	10.32	4.1						
	99.8	139	1.0	9.02	4.0						
	113.5	122	1.1	7.93	3.9						
	141.5	98	1.1	6.36	3.8						
	187.5	74	1.3	4.80	3.5						
	52.3	263	0.8	26.79	5.1	A/F 252 90L4C / 90L4D	23	118			
	57.9	238	0.8	24.19	5.1						
	60.8	226	0.9	23.04	5.0						
	69.3	198	1.0	20.19	4.4						
	75.7	182	1.1	18.49	4.4						
	82.1	167	1.1	17.05	4.4						
	93.9	146	1.2	14.91	4.3						
	100.4	137	1.2	13.94	4.3						
	117.0	118	1.2	11.97	4.2						
	135.7	101	1.4	10.32	4.1						
	155.2	89	1.5	9.02	4.0						
	176.5	78	1.6	7.93	3.9						
	220.1	62	1.7	6.36	3.8						
	291.7	47	2.0	4.80	3.5						
	66.7	200	0.8	42.00	5.1	A/F 252 90L2B / 90L2C	23	118			
	72.8	183	0.8	38.46	5.1						
	83.9	159	1.0	33.38	5.1						
	92.9	144	1.1	30.15	5.1						
	104.5	128	1.2	26.79	5.1						
	115.8	115	1.3	24.19	5.1						
	121.5	110	1.4	23.04	5.0						
	138.7	96	1.6	20.19	4.4						
	151.4	88	1.7	18.49	4.4						
	164.2	81	1.8	17.05	4.4						
	187.8	71	1.8	14.91	4.3						
	200.9	66	1.9	13.94	4.3						
	233.9	57	1.9	11.97	4.2						
271.3	49	2.2	10.32	4.1							
310.4	43	2.3	9.02	4.0							
353.1	38	2.5	7.93	3.9							
440.3	30	2.6	6.36	3.8							
122.7	112	0.8	11.41	2.8	A/F 202 G 90L4C / 90L4D	18	116				
129.0	107	0.8	10.85	2.8							
142.7	96	0.9	9.81	2.8							
160.0	86	1.0	8.75	2.8							
179.3	77	1.1	7.81	2.8							
198.9	69	1.2	7.04	2.8							
218.4	63	1.3	6.41	2.8							
243.9	56	1.4	5.74	2.8							
271.3	51	1.6	5.16	2.8							
302.4	45	1.6	4.63	2.8							
334.1	41	1.6	4.19	2.8							
367.5	37	1.6	3.81	2.8							
407.0	34	1.6	3.44	2.8							
432.1	32	1.7	3.24	2.8							
474.6	29	1.7	2.95	2.8							
510.9	27	1.7	2.74	2.8							
557.8	25	1.7	2.51	2.8							
606.1	23	1.9	2.31	2.8							



P ₁ [kW]	n ₂ [Min ⁻¹]	M ₂ [Nm]	f _B	i _{ges}	FR (a) [kN]	Tip / Type / Typ / Tipo / Type / Tipo IE2 / IE3	 Kg ~	 mm				
1.50	245.4	54	1.2	11.41	2.8	A/F 202 G 90L2B / 90L2C	18	116				
	258.1	52	1.3	10.85	2.8							
	285.4	47	1.4	9.81	2.8							
	320.0	42	1.6	8.75	2.8							
	358.5	37	1.7	7.81	2.8							
	397.7	34	1.9	7.04	2.8							
	436.8	31	2.0	6.41	2.8							
	487.8	27	2.1	5.74	2.8							
	542.6	25	2.6	5.16	2.8							
	604.8	22	2.5	4.63	2.8							
	668.3	20	2.5	4.19	2.8							
	734.9	18	2.5	3.81	2.8							
	814.0	16	2.5	3.44	2.8							
	864.2	15	2.7	3.24	2.8							
	949.2	14	2.7	2.95	2.8							
	1021.9	13	2.7	2.74	2.8							
1115.5	12	2.7	2.51	2.8								
1212.1	11	3.0	2.31	2.8								
2.20	3.5	5804	0.9	260.15	30.0	A/F 703 112M6C / 112M6D	131	142				
	3.9	5161	1.0	231.34	30.0							
	4.3	4635	1.1	207.78	30.0							
	4.7	4229	1.2	189.54	30.0							
	5.2	3862	1.4	173.11	30.0							
	5.8	3469	1.5	155.48	30.0							
	6.2	3234	1.6	144.94	30.0							
	7.0	2863	1.8	128.35	30.0							
	7.6	2649	2.0	118.75	30.0							
	8.3	2420	2.2	108.46	30.0							
	9.0	2239	2.3	100.38	30.0							
	10.0	2007	2.6	89.95	30.0							
	10.8	1860	2.8	83.35	30.0							
		5.4	3670	1.4	260.15				30.0	A/F 703 100L4B / 100L4C	123	142
		6.1	3263	1.5	231.34				30.0			
		6.7	2931	1.7	207.78				30.0			
		7.4	2674	1.9	189.54	30.0						
		8.1	2442	2.0	173.11	30.0						
		9.0	2193	2.3	155.48	30.0						
		9.7	2045	2.4	144.94	30.0						
		10.9	1811	2.8	128.35	30.0						
	11.8	1675	3.0	118.75	30.0							
		4.2	4809	0.8	215.56	22.0	A/F 603 112M6C / 112M6D	101	138			
		4.6	4335	0.8	194.31	22.0						
		5.0	4041	0.9	181.13	22.0						
		5.6	3590	1.0	160.90	22.0						
		6.3	3203	1.1	143.57	22.0						
		6.7	2995	1.2	134.25	22.0						
		7.4	2700	1.4	121.02	22.0						
		9.0	2236	1.6	100.21	22.0						
		9.6	2088	1.8	93.60	22.0						
		10.7	1882	2.0	84.37	22.0						
		11.3	1784	2.1	79.98	22.0						
		12.9	1559	2.4	69.87	22.0						
		5.8	3423	1.1	242.67	22.0	A/F 603 100L4B / 100L4C	94	138			
		6.5	3041	1.2	215.56	22.0						
		7.2	2741	1.3	194.31	22.0						
		7.7	2555	1.4	181.13	22.0						
		8.7	2270	1.5	160.90	22.0						
		9.8	2025	1.7	143.57	22.0						
		10.4	1894	1.8	134.25	22.0						
		11.6	1707	2.1	121.02	22.0						
		14.0	1414	2.5	100.21	22.0						
		15.0	1320	2.7	93.60	22.0						
		16.6	1190	2.9	84.37	22.0						
			11.5	1636	1.7	242.67				22.0	A/F 603 90L2D	84
	13.0		1454	1.8	215.56	22.0						
	14.4		1310	2.0	194.31	22.0						
15.5	1221		2.2	181.13	22.0							
17.4	1085		2.5	160.90	22.0							
19.5	968		2.7	143.57	22.0							



P₁ [kW]	n₂ [Min ⁻¹]	M₂ [Nm]	f_B	i_{ges}	FR (a) [kN]	Tip / Type / Typ / Tipo / Type / Tipo IE2 / IE3	kg ~	mm
2.20	17.7	1153	3.0	50.91	22.0	A/F 602 112M6C / 112M6D	101	138
	8.0 9.2 10.5 11.4 12.6 16.0	2512 2182 1904 1754 1590 1254	0.8 0.9 1.0 1.1 1.2 1.3	112.61 97.80 85.33 78.64 71.27 56.21	18.0 18.0 18.0 18.0 18.0 18.0	A/F 503 112M6C / 112M6D	75	134
	9.1 9.9 11.3 12.4 14.3 16.4 17.8 19.6 24.9	2180 2003 1753 1589 1380 1204 1109 1005 793	0.8 0.9 1.0 1.1 1.3 1.5 1.6 1.8 2.0	154.52 142.00 124.25 112.61 97.80 85.33 78.64 71.27 56.21	18.0 18.0 18.0 18.0 18.0 18.0 18.0 18.0 18.0	A/F 503 100L4B / 100L4C	67	134
	12.6 14.4 15.6 17.3 18.1 19.7 22.5 24.9 28.6 32.8 35.6 39.3	1501 1314 1207 1094 1042 957 838 759 659 575 530 481	0.9 1.0 1.1 1.3 1.3 1.4 1.6 1.8 2.1 2.4 2.6 2.8	222.59 194.86 178.98 162.21 154.52 142.00 124.25 112.61 97.80 85.33 78.64 71.27	18.0 18.0 18.0 18.0 18.0 18.0 18.0 18.0 18.0 18.0 18.0 18.0	A/F 503 90L2D	57	134
	18.5 20.8 23.0 25.8 28.5 31.8 33.4	1105 981 888 789 715 640 611	1.5 1.7 1.9 2.1 2.3 2.6 2.7	48.77 43.32 39.21 34.83 31.57 28.26 26.98	18.0 18.0 18.0 18.0 18.0 18.0 18.0	A/F 502 112M6C / 112M6D	75	134
	28.7 32.3 35.7	703 624 565	2.3 2.6 2.8	48.77 43.32 39.21	18.0 18.0 18.0	A/F 502 100L4B / 100L4C	67	134
	105.1 118.4 145.9 160.1	197 175 142 129	1.9 2.1 2.5 2.7	8.56 7.60 6.17 5.62	4.0 4.0 4.0 4.0	A/F 501 112M6C / 112M6D	50	132
	163.6	126	2.8	8.56	4.0	A/F 501 100L4B / 100L4C	42	132
	18.1	1107	0.8	49.64	12.0	A/F 403 112M6C / 112M6D	58	130
	20.5 25.5 28.2	963 773 700	0.9 1.1 1.2	68.25 54.81 49.64	12.0 12.0 12.0	A/F 403 100L4B / 100L4C	50	130
	23.7 29.5 32.6 41.0 51.1 56.4	797 640 579 460 370 335	0.8 1.0 1.1 1.4 1.7 1.9	118.13 94.86 85.91 68.25 54.81 49.64	12.0 12.0 12.0 12.0 12.0 12.0	A/F 403 90L2D	40	130



P ₁ [kW]	n ₂ [Min ⁻¹]	M ₂ [Nm]	f _B	i _{ges}	FR (a) [kN]	Tip / Type / Typ / Tipo / Type / Tipo IE2 / IE3	Kg ~	mm		
2.20	19.8	1028	0.9	45.38	12.0	A/F 402 112M6C / 112M6D	58	130		
	22.7	900	1.0	39.72	12.0					
	24.7	825	1.0	36.44	12.0					
	28.6	713	1.3	31.50	12.0					
	31.2	654	1.3	28.89	12.0					
	35.6	573	1.6	25.30	12.0					
	39.3	519	1.7	22.91	12.0					
	45.1	452	2.0	19.94	12.0					
	51.8	393	2.2	17.37	12.0					
	56.2	363	2.3	16.01	12.0					
	62.1	328	2.2	14.50	12.0					
	72.3	282	2.6	12.44	12.0					
	78.5	260	2.6	11.46	12.0					
	97.8	208	3.0	9.20	12.0					
	30.9	654	1.3	45.38	12.0	A/F 402 100L4B / 100L4C	50	130		
	35.2	572	1.5	39.72	12.0					
	38.4	525	1.5	36.44	12.0					
	44.4	454	1.9	31.50	12.0					
	48.5	416	1.9	28.89	12.0					
	55.3	364	2.3	25.30	12.0					
	61.1	330	2.6	22.91	12.0					
	70.2	287	3.0	19.94	12.0					
	61.7	317	2.0	45.38	12.0	A/F 402 90L2D	40	130		
	70.5	278	2.3	39.72	12.0					
	76.8	255	2.4	36.44	12.0					
	88.9	220	2.9	31.50	12.0					
	96.9	202	3.0	28.89	12.0					
	109.1	190	0.9	8.25	3.7	A/F 401 112M6C / 112M6D	44	128		
	124.7	166	1.1	7.22	3.7					
	157.1	132	1.4	5.73	3.7					
	174.1	119	1.5	5.17	3.7					
	191.9	108	1.6	4.69	3.7					
	229.0	90	1.7	3.93	3.5					
	247.9	83	1.9	3.63	3.4					
	289.4	72	1.9	3.11	3.3					
	357.1	58	2.2	2.52	3.1					
	432.7	48	2.6	2.08	2.9					
	687.0	30	2.8	1.31	2.5					
	169.7	121	1.4	8.25	3.7				A/F 401 100L4B / 100L4C	36
	193.9	106	1.6	7.22	3.7					
	244.3	84	2.0	5.73	3.7					
	270.8	76	2.2	5.17	3.7					
298.5	69	2.3	4.69	3.7						
356.2	58	2.6	3.93	3.5						
385.7	53	2.8	3.63	3.4						
450.2	46	2.8	3.11	3.3						
339.4	60	2.2	8.25	3.7	A/F 401 90L2D	26	128			
387.8	52	2.5	7.22	3.7						
38.6	489	0.8	72.58	8.0	A/F 353 90L2D	31	126			
47.7	396	1.0	58.68	8.0						
31.2	654	0.8	28.89	8.0	A/F 352 112M6C / 112M6D	48	126			
33.8	602	0.9	26.59	8.0						
35.8	569	0.9	25.13	8.0						
40.9	499	1.0	22.03	8.0						
44.3	460	1.0	20.31	8.0						
49.2	414	1.2	18.30	7.9						
53.3	382	1.2	16.88	7.8						
62.0	329	1.4	14.52	7.5						
76.7	266	1.5	11.74	7.2						
92.3	221	1.8	9.75	6.9						
103.1	198	1.8	8.73	6.7						
127.5	160	1.9	7.06	6.3						
153.6	133	2.1	5.86	6.0						

P_1 [kW]	n_2 [Min ⁻¹]	M_2 [Nm]	f_B	i_{ges}	FR (a) [kN]	Tip / Type / Typ / Tipo / Type / Tipo IE2 / IE3	 Kg ~	 mm	
2.20	35.4	570	0.9	39.59	8.0	A/F 352 100L4B / 100L4C	41	126	
	43.7	461	1.1	32.01	8.0				
	48.5	416	1.2	28.89	8.0				
	52.7	383	1.3	26.59	8.0				
	55.7	362	1.3	25.13	8.0				
	63.5	317	1.5	22.03	8.0				
	68.9	293	1.6	20.31	8.0				
	76.5	264	1.7	18.30	7.9				
	82.9	243	1.9	16.88	7.8				
	96.4	209	2.1	14.52	7.5				
	119.3	169	2.3	11.74	7.2				
	143.6	140	2.6	9.75	6.9				
	160.4	126	2.7	8.73	6.7				
	198.3	102	2.9	7.06	6.3				
		49.2	398	0.9	56.95	8.0	A/F 352 90L2D	31	126
	56.1	349	1.1	49.88	8.0				
	60.8	322	1.2	46.04	8.0				
	70.7	277	1.3	39.59	8.0				
	83.6	234	1.6	33.50	8.0				
	87.5	224	1.7	32.01	8.0				
	96.9	202	1.8	28.89	8.0				
	105.3	186	2.0	26.59	8.0				
	111.4	176	2.0	25.13	8.0				
	127.1	154	2.3	22.03	8.0				
	137.9	142	2.5	20.31	8.0				
	153.0	128	2.7	18.30	7.9				
	165.9	118	2.9	16.88	7.8				
		152.3	136	0.8	5.91	2.4	A/F 351 112M6C / 112M6D	40	124
	168.9	123	0.9	5.33	2.3				
	185.6	112	0.9	4.85	2.3				
	221.1	94	1.0	4.07	2.2				
	240.0	86	1.1	3.75	2.1				
	279.5	74	1.1	3.22	2.1				
	343.5	60	1.2	2.62	1.9				
	414.7	50	1.3	2.17	1.8				
	620.7	33	1.9	1.45	1.6				
	692.3	30	1.4	1.30	1.6				
		236.9	87	1.2	5.91	2.4	A/F 351 100L4B / 100L4C	32	124
	262.7	78	1.3	5.33	2.3				
	288.7	71	1.3	4.85	2.3				
	344.0	60	1.5	4.07	2.2				
	373.3	55	1.6	3.75	2.1				
	434.8	47	1.7	3.22	2.1				
	534.4	39	1.8	2.62	1.9				
	645.2	32	1.9	2.17	1.8				
	965.5	21	2.8	1.45	1.6				
	1076.9	19	2.1	1.30	1.6				
		329.4	62	1.2	8.50	2.5	A/F 351 90L2D	22	124
	376.3	54	1.4	7.44	2.5				
	473.8	43	1.8	5.91	2.4				
	525.3	39	2.0	5.33	2.3				
	577.3	35	2.1	4.85	2.3				
	688.0	29	2.3	4.07	2.2				
	746.7	27	2.5	3.75	2.1				
	869.6	23	2.6	3.22	2.1				
	1290.3	16	2.9	2.17	1.8				
		65.2	313	0.8	13.81	5.5			
	75.0	272	1.0	12.00	5.3				
	85.7	238	1.1	10.50	5.2				
	98.8	206	1.1	9.11	5.1				
	122.6	166	1.0	7.34	4.9				
	161.3	126	1.3	5.58	4.6				
		65.6	307	0.8	21.33	6.5	A/F 302 100L4B / 100L4C	36	122
	72.6	278	0.9	19.29	5.6				
	86.4	234	1.1	16.21	5.6				
	101.4	199	1.3	13.81	5.5				
	116.7	173	1.4	12.00	5.3				
	133.3	151	1.6	10.50	5.2				
	153.7	131	1.6	9.11	5.1				
	190.7	106	1.5	7.34	4.9				
	250.9	80	2.0	5.58	4.6				



P ₁ [kW]	n ₂ [Min ⁻¹]	M ₂ [Nm]	f _B	i _{ges}	FR (a) [kN]	Tip / Type / Typ / Tipo / Type / Tipo IE2 / IE3	 Kg ~	 mm
2.20	73.0	268	0.8	38.33	6.5	A/F 302 90L2D	26	122
	80.9	242	0.9	34.62	6.5			
	90.6	216	1.0	30.91	6.5			
	100.3	195	1.1	27.92	6.5			
	105.9	185	1.1	26.45	6.5			
	119.2	164	1.2	23.49	6.5			
	131.3	149	1.3	21.33	6.5			
	145.2	135	1.4	19.29	5.6			
	172.7	113	1.7	16.21	5.6			
	202.8	96	2.0	13.81	5.5			
233.3	84	2.3	12.00	5.3				
266.7	73	2.5	10.50	5.2				
307.4	64	2.5	9.11	5.1				
381.5	51	2.4	7.34	4.9				
453.1	45	0.8	6.18	0.9	A/F 301 90L2D	20	120	
501.8	40	0.9	5.58	0.9				
551.2	37	0.9	5.08	0.9				
655.7	31	1.1	4.27	0.9				
767.1	26	1.3	3.65	0.9				
886.1	23	1.3	3.16	0.9				
1014.5	20	1.1	2.76	0.9				
1081.1	19	1.2	2.59	0.9				
1372.5	15	1.3	2.04	0.9				
1904.8	11	1.8	1.47	0.9				
141.5	144	0.8	6.36	3.5	A/F 252 112M6C / 112M6D	40	118	
187.5	109	0.9	4.80	3.3				
75.7	266	0.8	18.49	4.4	A/F 252 100L4B / 100L4C	33	118	
82.1	246	0.8	17.05	4.4				
93.9	215	0.8	14.91	4.3				
100.4	201	0.8	13.94	4.3				
117.0	172	0.8	11.97	4.2				
135.7	149	0.9	10.32	3.6				
155.2	130	1.0	9.02	3.6				
176.5	114	1.1	7.93	3.6				
220.1	92	1.1	6.36	3.5				
291.7	69	1.4	4.80	3.3				
104.5	187	0.8	26.79	5.1	A/F 252 90L2D	23	118	
115.8	169	0.9	24.19	5.1				
121.5	161	0.9	23.04	5.0				
138.7	141	1.1	20.19	4.4				
151.4	129	1.2	18.49	4.4				
164.2	119	1.2	17.05	4.4				
187.8	104	1.2	14.91	4.3				
200.9	97	1.3	13.94	4.3				
233.9	84	1.3	11.97	4.2				
271.3	72	1.5	10.32	3.6				
310.4	63	1.6	9.02	3.6				
353.1	55	1.7	7.93	3.6				
440.3	44	1.8	6.36	3.5				
583.3	34	2.2	4.80	3.3				
245.4	80	0.8	11.41	2.8				A/F 202 G 90L2D
258.1	76	0.9	10.85	2.8				
285.4	69	0.9	9.81	2.8				
320.0	61	1.1	8.75	2.8				
358.5	55	1.1	7.81	2.8				
397.7	49	1.3	7.04	2.8				
436.8	45	1.4	6.41	2.8				
487.8	40	1.5	5.74	2.8				
542.6	36	1.7	5.16	2.8				
604.8	32	1.7	4.63	2.8				
668.3	29	1.7	4.19	2.8				
734.9	27	1.7	3.81	2.8				
814.0	24	1.7	3.44	2.8				
864.2	23	1.8	3.24	2.8				
949.2	21	1.8	2.95	2.8				
1021.9	19	1.8	2.74	2.8				
1115.5	18	1.9	2.51	2.8				
1212.1	16	2.0	2.31	2.8				



P ₁ [kW]	n ₂ [Min ⁻¹]	M ₂ [Nm]	f _B	i _{ges}	FR (a) [kN]	Tip / Type / Typ / Tipo / Type / Tipo IE2 / IE3	 Kg ~	 mm
3.00	4.3	6321	0.8	207.78	30.0	A/F 703 132S6A	153	142
	4.7	5766	0.9	189.54	30.0			
	5.2	5266	1.0	173.11	30.0			
	5.8	4730	1.1	155.48	30.0			
	6.2	4409	1.2	144.94	30.0			
	7.0	3905	1.3	128.35	30.0			
	7.6	3613	1.5	118.75	30.0			
	8.3	3300	1.6	108.46	30.0			
	9.0	3054	1.7	100.38	30.0			
	10.0	2736	1.9	89.95	30.0			
10.8	2536	2.1	83.35	30.0	A/F 703 100L4C / 100L4D	123	142	
12.2	2242	2.3	73.70	30.0				
13.4	2048	2.6	67.31	30.0				
5.4	5004	1.0	260.15	30.0				
6.1	4450	1.1	231.34	30.0				
6.7	3997	1.3	207.78	30.0				
7.4	3646	1.4	189.54	30.0				
8.1	3330	1.5	173.11	30.0				
9.0	2991	1.7	155.48	30.0				
9.7	2788	1.8	144.94	30.0				
10.9	2469	2.0	128.35	30.0				
11.8	2284	2.2	118.75	30.0				
12.9	2086	2.4	108.46	30.0				
13.9	1931	2.6	100.38	30.0				
15.6	1730	2.9	89.95	30.0				
10.8	2392	1.6	260.15	30.0	A/F 703 100L2C / 100L2D	123	142	
12.1	2127	1.8	231.34	30.0				
13.5	1911	2.0	207.78	30.0				
14.8	1743	2.2	189.54	30.0				
16.2	1592	2.4	173.11	30.0				
18.0	1430	2.7	155.48	30.0				
19.3	1333	2.9	144.94	30.0	A/F 603 132S6A	124	138	
5.6	4895	0.8	160.90	22.0				
6.3	4368	0.8	143.57	22.0				
6.7	4084	0.9	134.25	22.0				
7.4	3682	1.0	121.02	22.0				
9.0	3049	1.2	100.21	22.0				
9.6	2848	1.3	93.60	22.0				
10.7	2567	1.4	84.37	22.0				
11.3	2433	1.5	79.98	22.0				
12.9	2126	1.7	69.87	22.0				
16.1	1696	2.2	55.75	22.0	A/F 603 100L4C / 100L4D	94	138	
5.8	4668	0.8	242.67	22.0				
6.5	4147	0.8	215.56	22.0				
7.2	3738	0.9	194.31	22.0				
7.7	3484	1.0	181.13	22.0				
8.7	3095	1.1	160.90	22.0				
9.8	2762	1.3	143.57	22.0				
10.4	2582	1.4	134.25	22.0				
11.6	2328	1.5	121.02	22.0				
14.0	1928	1.8	100.21	22.0				
15.0	1801	1.9	93.60	22.0	A/F 603 100L2C / 100L2D	94	138	
16.6	1623	2.2	84.37	22.0				
17.5	1539	2.3	79.98	22.0				
20.0	1344	2.6	69.87	22.0				
11.5	2231	1.2	242.67	22.0				
13.0	1982	1.3	215.56	22.0				
14.4	1787	1.5	194.31	22.0				
15.5	1665	1.6	181.13	22.0				
17.4	1479	1.8	160.90	22.0				
19.5	1320	2.0	143.57	22.0				
20.9	1234	2.2	134.25	22.0	A/F 602 132S6A	124	138	
23.1	1113	2.4	121.02	22.0				
27.9	921	2.9	100.21	22.0				
17.7	1572	2.2	50.91	22.0				
19.9	1398	2.5	45.27	22.0				
22.1	1260	2.7	40.81	22.0				
23.7	1174	2.5	38.00	22.0				



P ₁ [kW]	n ₂ [Min ⁻¹]	M ₂ [Nm]	f _B	i _{ges}	FR (a) [kN]	Tip / Type / Typ / Tipo / Type / Tipo IE2 / IE3	 Kg ~	 mm	
3.00	108.4 120.8	260 234	2.6 2.9	8.30 7.45	5.0 5.0	A/F 601 132S6A	89	136	
	11.4 12.6 16.0	2392 2168 1710	0.8 0.9 1.0	78.64 71.27 56.21	18.0 18.0 18.0	A/F 503 132S6A	97	134	
	11.3 12.4 14.3 16.4 17.8 19.6 24.9	2390 2166 1881 1641 1513 1371 1081	0.8 0.8 1.0 1.1 1.2 1.3 1.5	124.25 112.61 97.80 85.33 78.64 71.27 56.21	18.0 18.0 18.0 18.0 18.0 18.0 18.0	A/F 503 100L4C / 100L4D	67	134	
	18.1 19.7 22.5 24.9 28.6 32.8 35.6 39.3 49.8	1421 1306 1142 1035 899 785 723 655 517	1.0 1.0 1.2 1.3 1.5 1.7 1.9 2.1 2.4	154.52 142.00 124.25 112.61 97.80 85.33 78.64 71.27 56.21	18.0 18.0 18.0 18.0 18.0 18.0 18.0 18.0 18.0	A/F 503 100L2C / 100L2D	67	134	
	18.5 20.8 23.0 25.8 28.5 31.8 33.4 38.9 41.5 45.8 47.8 53.4	1506 1338 1211 1076 975 873 833 715 670 607 581 521	1.1 1.3 1.4 1.6 1.7 1.9 2.0 2.4 2.5 2.8 2.7 3.0	48.77 43.32 39.21 34.83 31.57 28.26 26.98 23.14 21.69 19.66 18.81 16.86	18.0 18.0 18.0 18.0 18.0 18.0 18.0 18.0 18.0 18.0 18.0 18.0	A/F 502 132S6A	97	134	
	28.7 32.3 35.7 40.2 44.3 49.5 51.9	958 851 770 684 620 555 530	1.7 1.9 2.1 2.3 2.6 2.9 3.0	48.77 43.32 39.21 34.83 31.57 28.26 26.98	18.0 18.0 18.0 18.0 18.0 18.0 18.0	A/F 502 100L4C / 100L4D	67	134	
	57.4 64.6	465 413	2.6 2.9	48.77 43.32	18.0 18.0	A/F 502 100L2C / 100L2D	67	134	
	105.1 118.4 145.9 160.1 190.3 221.7 238.1	268 238 193 176 148 127 119	1.4 1.5 1.8 2.0 2.3 2.6 2.7	8.56 7.60 6.17 5.62 4.73 4.06 3.78	4.0 4.0 4.0 4.0 4.0 4.0 4.0	A/F 501 132S6A	72	132	
	163.6 184.2 226.9 249.1	172 152 124 113	2.0 2.3 2.7 2.9	8.56 7.60 6.17 5.62	4.0 4.0 4.0 4.0	A/F 501 100L4C / 100L4D	42	132	
	25.5 28.2	1054 955	0.8 0.9	54.81 49.64	12.0 12.0	A/F 403 100L4C / 100L4D	50	130	
	32.6 41.0 51.1 56.4	790 628 504 456	0.8 1.0 1.3 1.4	85.91 68.25 54.81 49.64	12.0 12.0 12.0 12.0	A/F 403 100L2C / 100L2D	50	130	



P ₁ [kW]	n ₂ [Min ⁻¹]	M ₂ [Nm]	f _B	i _{ges}	FR (a) [kN]	Tip / Type / Typ / Tipo / Type / Tipo IE2 / IE3	 Kg ~	 mm			
3.00	28.6	973	0.9	31.50	12.0	A/F 402 132S6A	80	130			
	35.6	781	1.1	25.30	12.0						
	39.3	708	1.3	22.91	12.0						
	45.1	616	1.4	19.94	12.0						
	51.8	536	1.6	17.37	12.0						
	56.2	494	1.7	16.01	12.0						
	62.1	448	1.6	14.50	12.0						
	72.3	384	1.9	12.44	12.0						
	78.5	354	1.9	11.46	12.0						
	97.8	284	2.2	9.20	12.0						
	108.0	257	2.4	8.33	12.0						
	124.7	223	2.6	7.22	12.0						
	30.9	892	1.0	45.38	12.0				A/F 402 100L4C / 100L4D	50	130
	35.2	780	1.1	39.72	12.0						
	38.4	716	1.1	36.44	12.0						
	44.4	619	1.4	31.50	12.0						
	48.5	568	1.4	28.89	12.0						
	55.3	497	1.7	25.30	12.0						
	61.1	450	1.9	22.91	12.0						
	70.2	392	2.2	19.94	12.0						
	80.6	341	2.4	17.37	12.0						
	87.4	315	2.5	16.01	12.0						
	96.6	285	2.5	14.50	12.0						
	112.5	244	2.9	12.44	12.0						
	122.2	225	2.9	11.46	12.0						
	61.7	432	1.5	45.38	12.0	A/F 402 100L2C / 100L2D	50	130			
	70.5	378	1.7	39.72	12.0						
	76.8	347	1.8	36.44	12.0						
	88.9	300	2.2	31.50	12.0						
	96.9	275	2.2	28.89	12.0						
	110.7	241	2.7	25.30	12.0						
	122.2	218	3.0	22.91	12.0						
	169.7	165	1.0	8.25	3.7	A/F 401 100L4C / 100L4D	36	128			
	193.9	145	1.2	7.22	3.7						
	244.3	115	1.5	5.73	3.7						
	270.8	104	1.6	5.17	3.6						
	298.5	94	1.7	4.69	3.5						
	356.2	79	1.9	3.93	3.4						
	385.7	73	2.1	3.63	3.3						
	450.2	62	2.1	3.11	3.2						
	555.6	51	2.4	2.52	3.0						
	673.1	42	2.9	2.08	2.9						
	1068.7	26	3.0	1.31	2.5						
	339.4	81	1.6	8.25	3.7				A/F 401 100L2C / 100L2D	36	128
	387.8	71	1.8	7.22	3.7						
488.7	57	2.3	5.73	3.7							
541.6	51	2.5	5.17	3.6							
597.0	46	2.6	4.69	3.5							
712.5	39	2.9	3.93	3.4							
43.7	629	0.8	32.01	8.0	A/F 352 100L4C / 100L4D	41	126				
48.5	568	0.9	28.89	8.0							
52.7	522	0.9	26.59	7.4							
55.7	494	1.0	25.13	7.4							
63.5	433	1.1	22.03	7.4							
68.9	399	1.2	20.31	7.3							
76.5	360	1.3	18.30	7.2							
82.9	332	1.4	16.88	7.2							
96.4	285	1.5	14.52	7.0							
119.3	231	1.7	11.74	6.8							
143.6	192	1.9	9.75	6.5							
160.4	172	2.0	8.73	6.4							
198.3	139	2.1	7.06	6.1							
238.9	115	2.3	5.86	5.8							



P ₁ [kW]	n ₂ [Min ⁻¹]	M ₂ [Nm]	f _B	i _{ges}	FR (a) [kN]	Tip / Type / Typ / Tipo / Type / Tipo IE2 / IE3	Kg ~	mm
3.00	70.7	377	1.0	39.59	8.0	A/F 352 100L2C / 100L2D	41	126
	87.5	305	1.2	32.01	8.0			
	96.9	275	1.4	28.89	8.0			
	105.3	253	1.5	26.59	7.4			
	111.4	239	1.5	25.13	7.4			
	127.1	210	1.7	22.03	7.4			
	137.9	194	1.8	20.31	7.3			
	153.0	174	2.0	18.30	7.2			
	165.9	161	2.1	16.88	7.2			
	192.8	138	2.4	14.52	7.0			
238.5	112	2.6	11.74	6.8				
287.2	93	3.0	9.75	6.5				
	236.9	119	0.8	5.91	2.4	A/F 351 100L4C / 100L4D	32	124
	262.7	107	0.9	5.33	2.2			
	288.7	97	1.0	4.85	2.2			
	344.0	82	1.1	4.07	2.1			
	373.3	75	1.2	3.75	2.0			
	434.8	65	1.2	3.22	2.0			
	534.4	53	1.3	2.62	1.9			
	645.2	44	1.4	2.17	1.8			
	965.5	29	2.1	1.45	1.6			
	1076.9	26	1.5	1.30	1.6			
	473.8	58	1.3	5.91	2.4	A/F 351 100L2C / 100L2D	32	124
	525.3	53	1.4	5.33	2.2			
	577.3	48	1.5	4.85	2.2			
	688.0	40	1.7	4.07	2.1			
	746.7	37	1.8	3.75	2.0			
	869.6	32	1.9	3.22	2.0			
	1068.7	26	2.1	2.62	1.9			
	1290.3	21	2.1	2.17	1.8			
	2153.8	13	2.4	1.30	1.6			
		86.4	318	0.8	16.21			
101.4		271	0.9	13.81	4.9			
116.7		236	1.1	12.00	4.8			
133.3		206	1.2	10.50	4.8			
153.7		179	1.2	9.11	4.7			
190.7		144	1.1	7.34	4.6			
250.9		110	1.5	5.58	4.3			
	105.9	252	0.8	26.45	5.6	A/F 302 100L2C / 100L2D	36	122
	131.3	203	0.9	21.33	5.6			
	145.2	184	1.0	19.29	5.6			
	172.7	154	1.2	16.21	5.6			
	202.8	132	1.4	13.81	4.9			
	233.3	114	1.7	12.00	4.8			
	266.7	100	1.8	10.50	4.8			
	307.4	87	1.8	9.11	4.7			
	381.5	70	1.7	7.34	4.6			
	501.8	53	2.3	5.58	4.3			
	176.5	156	0.8	7.93	3.6	A/F 252 100L4C / 100L4D	33	118
	220.1	125	0.8	6.36	3.5			
	291.7	94	1.0	4.80	3.1			
	151.4	176	0.9	18.49	4.4	A/F 252 100L2C / 100L2D	33	118
	164.2	162	0.9	17.05	4.4			
	187.8	142	0.9	14.91	4.3			
	200.9	133	1.0	13.94	4.3			
	233.9	114	1.0	11.97	4.2			
	271.3	98	1.1	10.32	3.6			
	310.4	86	1.1	9.02	3.6			
	353.1	76	1.3	7.93	3.6			
	440.3	61	1.3	6.36	3.5			
	583.3	46	1.6	4.80	3.1			



P_1 [kW]	n_2 [Min ⁻¹]	M_2 [Nm]	f_B	i_{ges}	FR (a) [kN]	Tip / Type / Typ / Tipo / Type / Tipo IE2 / IE3	 Kg ~	 mm			
4.00	5.8	6307	0.8	155.48	30.0	A/F 703 132M6A	153	142			
	6.2	5879	0.9	144.94	30.0						
	7.0	5206	1.0	128.35	30.0						
	7.6	4817	1.1	118.75	30.0						
	8.3	4399	1.2	108.46	30.0						
	9.0	4072	1.3	100.38	30.0						
	10.0	3649	1.4	89.95	30.0						
	10.8	3381	1.6	83.35	30.0						
	12.2	2989	1.8	73.70	30.0						
	13.4	2730	1.9	67.31	30.0						
	16.1	2261	2.3	55.75	30.0						
	19.7	1853	2.8	45.67	30.0						
	6.1	5934	0.8	231.34	30.0				A/F 703 112M4C / 112M4D	131	142
	6.7	5329	0.9	207.78	30.0						
	7.4	4861	1.0	189.54	30.0						
	8.1	4440	1.1	173.11	30.0						
	9.0	3988	1.3	155.48	30.0						
	9.7	3718	1.3	144.94	30.0						
	10.9	3292	1.5	128.35	30.0						
	11.8	3046	1.6	118.75	30.0						
	12.9	2782	1.8	108.46	30.0						
	13.9	2575	1.9	100.38	30.0						
	15.6	2307	2.2	89.95	30.0						
	16.8	2138	2.3	83.35	30.0						
	19.0	1890	2.6	73.70	30.0						
	20.8	1726	2.9	67.31	30.0						
	10.8	3189	1.2	260.15	30.0	A/F 703 112M2B / 112M2C	131	142			
	12.1	2836	1.3	231.34	30.0						
	13.5	2547	1.5	207.78	30.0						
	14.8	2324	1.6	189.54	30.0						
	16.2	2122	1.8	173.11	30.0						
	18.0	1906	2.0	155.48	30.0						
	19.3	1777	2.1	144.94	30.0						
	21.8	1574	2.4	128.35	30.0						
	23.6	1456	2.6	118.75	30.0						
	25.8	1330	2.9	108.46	30.0						
	9.0	4065	0.9	100.21	22.0	A/F 603 132M6A	124	138			
	9.6	3797	1.0	93.60	22.0						
	10.7	3422	1.1	84.37	22.0						
	11.3	3244	1.1	79.98	22.0						
	12.9	2834	1.3	69.87	22.0						
	16.1	2261	1.6	55.75	22.0						
7.7	4646	0.8	181.13	22.0	A/F 603 112M4C / 112M4D	101	138				
8.7	4127	0.8	160.90	22.0							
9.8	3682	1.0	143.57	22.0							
10.4	3443	1.0	134.25	22.0							
11.6	3104	1.1	121.02	22.0							
14.0	2570	1.4	100.21	22.0							
15.0	2401	1.5	93.60	22.0							
16.6	2164	1.6	84.37	22.0							
17.5	2051	1.7	79.98	22.0							
20.0	1792	2.0	69.87	22.0							
11.5	2975	0.9	242.67	22.0	A/F 603 112M2B / 112M2C	101	138				
13.0	2643	1.0	215.56	22.0							
14.4	2382	1.1	194.31	22.0							
15.5	2221	1.2	181.13	22.0							
17.4	1973	1.3	160.90	22.0							
19.5	1760	1.5	143.57	22.0							
20.9	1646	1.6	134.25	22.0							
23.1	1484	1.8	121.02	22.0							
27.9	1229	2.2	100.21	22.0							
29.9	1148	2.3	93.60	22.0							
33.2	1034	2.6	84.37	22.0							
35.0	981	2.7	79.98	22.0							
17.7	2097	1.7	50.91	22.0				A/F 602 132M6A	124	138	
19.9	1864	1.9	45.27	22.0							
22.1	1681	2.1	40.81	22.0							
23.7	1565	1.9	38.00	22.0							
26.6	1391	2.4	33.79	22.0							
29.7	1250	2.7	30.35	22.0							
31.7	1168	3.0	28.36	22.0							



P_1 [kW]	n_2 [Min ⁻¹]	M_2 [Nm]	f_B	i_{ges}	FR (a) [kN]	Tip / Type / Typ / Tipo / Type / Tipo IE2 / IE3	 Kg ~	 mm	
4.00	27.5 30.9 36.8	1334 1186 995	2.5 2.8 2.8	50.91 45.27 38.00	22.0 22.0 22.0	A/F 602 112M4C / 112M4D	101	138	
	108.4 120.8 146.3 173.1	347 311 257 217	2.0 2.2 2.6 3.0	8.30 7.45 6.15 5.20	5.0 5.0 5.0 5.0	A/F 601 132M6A	89	136	
	168.7	222	2.9	8.30	5.0	A/F 601 112M4C / 112M4D	67	136	
	16.4 17.8 19.6 24.9	2189 2017 1828 1442	0.8 0.9 1.0 1.1	85.33 78.64 71.27 56.21	18.0 18.0 18.0 18.0	A/F 503 112M4C / 112M4D	75	134	
	19.7 22.5 24.9 28.6 32.8 35.6 39.3 49.8	1741 1523 1381 1199 1046 964 874 689	0.8 0.9 1.0 1.1 1.3 1.4 1.6 1.8	142.00 124.25 112.61 97.80 85.33 78.64 71.27 56.21	18.0 18.0 18.0 18.0 18.0 18.0 18.0 18.0	A/F 503 112M2B / 112M2C	75	134	
	18.5 20.8 23.0 25.8 28.5 31.8 33.4 38.9 41.5 45.8 47.8 53.4 59.5 65.6 80.4 99.9 110.3 119.2 148.3	2008 1784 1615 1434 1300 1164 1111 953 893 810 775 694 623 565 461 371 336 311 250	0.8 0.9 1.0 1.2 1.3 1.4 1.5 1.8 1.9 2.1 2.0 2.3 2.5 2.6 2.5 2.5 2.5 2.7 2.9	48.77 43.32 39.21 34.83 31.57 28.26 26.98 23.14 21.69 19.66 18.81 16.86 15.13 13.71 11.20 9.01 8.16 7.55 6.07	18.0 18.0 18.0 18.0 18.0 18.0 18.0 18.0 18.0 17.6 17.4 16.9 16.5 16.0 14.7 13.9 13.6 13.3 12.5	A/F 502 132M6A	97	134	
	28.7 32.3 35.7 40.2 44.3 49.5 51.9 60.5 64.5 74.4	1277 1135 1027 912 827 740 707 606 568 493	1.3 1.4 1.6 1.8 1.9 2.2 2.3 2.6 2.8 3.0	48.77 43.32 39.21 34.83 31.57 28.26 26.98 23.14 21.69 18.81	18.0 18.0 18.0 18.0 18.0 18.0 18.0 18.0 18.0 17.4	A/F 502 112M4C / 112M4D	75	134	
	57.4 64.6 71.4 80.4 88.7	620 550 498 443 401	2.0 2.2 2.4 2.7 3.0	48.77 43.32 39.21 34.83 31.57	18.0 18.0 18.0 18.0 18.0	A/F 502 112M2B / 112M2C	75	134	
	105.1 118.4 145.9 160.1 190.3 221.7 238.1 272.7 348.8 456.9	358 318 258 235 198 170 158 138 108 82	1.0 1.2 1.4 1.5 1.7 2.0 2.1 2.4 2.7 2.9	8.56 7.60 6.17 5.62 4.73 4.06 3.78 3.30 2.58 1.97	4.0 4.0 4.0 4.0 4.0 4.0 4.0 4.0 4.0 4.0	A/F 501 132M6A	72	132	

P ₁ [kW]	n ₂ [Min ⁻¹]	M ₂ [Nm]	f _B	i _{ges}	FR (a) [kN]	Tip / Type / Typ / Tipo / Type / Tipo IE2 / IE3	 Kg ~	 mm
4.00	163.6	229	1.5	8.56	4.0	A/F 501 112M4C / 112M4D	50	132
	184.2	203	1.7	7.60	4.0			
	226.9	165	2.1	6.17	4.0			
	249.1	150	2.2	5.62	4.0			
	296.0	126	2.5	4.73	4.0			
	344.8	109	2.9	4.06	4.0			
	327.1	113	2.4	8.56	4.0	A/F 501 112M2B / 112M2C	50	132
	368.4	100	2.7	7.60	4.0			
	41.0	837	0.8	68.25	12.0	A/F 403 112M2B / 112M2C	58	130
	51.1	672	1.0	54.81	12.0			
	56.4	609	1.1	49.64	12.0			
	35.6	1042	0.9	25.30	12.0	A/F 402 132M6A	80	130
	39.3	943	0.9	22.91	12.0			
	45.1	821	1.1	19.94	12.0			
	51.8	715	1.2	17.37	12.0			
	56.2	659	1.3	16.01	12.0			
	62.1	597	1.2	14.50	12.0			
	72.3	512	1.4	12.44	12.0			
	78.5	472	1.4	11.46	12.0			
	97.8	379	1.7	9.20	11.5			
	108.0	343	1.8	8.33	11.2			
	124.7	297	1.9	7.22	10.8			
	155.2	239	2.4	5.80	10.2			
	171.4	216	2.4	5.25	9.9			
	35.2	1040	0.8	39.72	12.0			
	38.4	955	0.8	36.44	12.0			
	44.4	825	1.0	31.50	12.0			
	48.5	757	1.1	28.89	12.0			
	55.3	663	1.3	25.30	12.0			
	61.1	600	1.4	22.91	12.0			
	70.2	522	1.6	19.94	12.0			
	80.6	455	1.8	17.37	12.0			
	87.4	419	1.9	16.01	12.0			
	96.6	380	1.8	14.50	12.0			
	112.5	326	2.1	12.44	12.0			
	122.2	300	2.2	11.46	12.0			
	152.2	241	2.5	9.20	11.5			
	168.1	218	2.7	8.33	11.2			
	193.9	189	2.9	7.22	10.8			
	61.7	577	1.1	45.38	12.0	A/F 402 112M2B / 112M2C	58	130
	70.5	505	1.3	39.72	12.0			
	76.8	463	1.3	36.44	12.0			
	88.9	400	1.6	31.50	12.0			
	96.9	367	1.7	28.89	12.0			
	110.7	321	2.0	25.30	12.0			
	122.2	291	2.2	22.91	12.0			
	140.4	253	2.6	19.94	12.0			
	161.2	221	2.9	17.37	12.0			
174.9	203	3.0	16.01	12.0				
193.1	184	2.9	14.50	12.0				
169.7	221	0.8	8.25	3.7	A/F 401 112M4C / 112M4D	44	128	
193.9	193	0.9	7.22	3.7				
244.3	153	1.1	5.73	3.5				
270.8	138	1.2	5.17	3.4				
298.5	125	1.3	4.69	3.3				
356.2	105	1.4	3.93	3.2				
385.7	97	1.5	3.63	3.2				
450.2	83	1.6	3.11	3.1				
555.6	67	1.8	2.52	2.9				
673.1	56	2.2	2.08	2.8				
1068.7	35	2.3	1.31	2.5				
339.4	109	1.2	8.25	3.7	A/F 401 112M2B / 112M2C	44	128	
387.8	95	1.4	7.22	3.7				
488.7	75	1.7	5.73	3.5				
541.6	68	1.9	5.17	3.4				
597.0	62	2.0	4.69	3.3				
712.5	52	2.2	3.93	3.2				
771.3	48	2.4	3.63	3.2				
900.3	41	2.4	3.11	3.1				
1111.1	33	2.7	2.52	2.9				



P ₁ [kW]	n ₂ [Min ⁻¹]	M ₂ [Nm]	f _B	i _{ges}	FR (a) [kN]	Tip / Type / Typ / Tipo / Type / Tipo IE2 / IE3	 ~	
4.00	63.5	577	0.8	22.03	7.4	A/F 352 112M4C / 112M4D	48	126
	68.9	532	0.9	20.31	7.3			
	76.5	479	1.0	18.30	6.5			
	82.9	442	1.0	16.88	6.4			
	96.4	380	1.1	14.52	6.4			
	119.3	308	1.3	11.74	6.3			
	143.6	255	1.4	9.75	6.1			
	160.4	229	1.5	8.73	6.0			
	198.3	185	1.6	7.06	5.8			
	238.9	153	1.7	5.86	5.6			
	87.5	407	0.9	32.01	7.4	A/F 352 112M2B / 112M2C	48	126
	96.9	367	1.0	28.89	7.4			
	105.3	338	1.1	26.59	7.4			
	111.4	319	1.1	25.13	7.4			
	127.1	280	1.3	22.03	7.4			
	137.9	258	1.4	20.31	7.3			
	153.0	232	1.5	18.30	6.5			
	165.9	214	1.6	16.88	6.4			
	192.8	184	1.8	14.52	6.4			
	238.5	149	2.0	11.74	6.3			
	287.2	124	2.3	9.75	6.1			
	320.7	111	2.3	8.73	6.0			
	396.6	90	2.5	7.06	5.8			
	477.8	74	2.7	5.86	5.6			
	344.0	109	0.8	4.07	2.1	A/F 351 112M4C / 112M4D	40	124
	373.3	100	0.9	3.75	1.9			
	434.8	86	0.9	3.22	1.9			
	534.4	70	1.0	2.62	1.8			
645.2	58	1.0	2.17	1.7				
965.5	39	1.5	1.45	1.6				
1076.9	35	1.2	1.30	1.5				
473.8	78	1.0	5.91	2.1	A/F 351 112M2B / 112M2C	40	124	
525.3	70	1.1	5.33	2.1				
577.3	64	1.1	4.85	2.1				
688.0	54	1.3	4.07	2.1				
746.7	49	1.4	3.75	1.9				
869.6	42	1.4	3.22	1.9				
1068.7	34	1.5	2.62	1.8				
1290.3	29	1.6	2.17	1.7				
1931.0	19	2.4	1.45	1.6				
2153.8	17	1.8	1.30	1.5				
116.7	314	0.8	12.00	4.8	A/F 302 112M4C / 112M4D	43	122	
133.3	275	0.9	10.50	4.8				
153.7	239	0.9	9.11	4.7				
190.7	192	0.8	7.34	4.6				
250.9	146	1.1	5.58	4.1				
145.2	245	0.8	19.29	4.8	A/F 302 112M2B / 112M2C	43	122	
172.7	206	0.9	16.21	4.8				
202.8	175	1.1	13.81	4.8				
233.3	152	1.2	12.00	4.8				
266.7	133	1.4	10.50	4.8				
307.4	116	1.4	9.11	4.7				
381.5	93	1.3	7.34	4.6				
501.8	71	1.7	5.58	4.1				
291.7	126	0.8	4.80	3.1	A/F 252 112M4C / 112M4D	40	118	
271.3	131	0.8	10.32	3.6	A/F 252 112M2B / 112M2C	40	118	
310.4	115	0.9	9.02	3.6				
353.1	101	0.9	7.93	3.6				
440.3	81	1.0	6.36	3.5				
583.3	61	1.2	4.80	3.1				



P ₁ [kW]	n ₂ [Min ⁻¹]	M ₂ [Nm]	f _B	i _{ges}	FR (a) [kN]	Tip / Type / Typ / Tipo / Type / Tipo IE2 / IE3	 Kg ~	 mm			
5.50	4.8	10354	0.8	185.64	55.0	A/F 903 132M6B	236	144			
	5.8	8593	1.0	154.07	55.0						
	6.5	7775	1.1	139.41	55.0						
	7.0	7159	1.2	128.36	55.0						
	7.8	6460	1.3	115.83	55.0						
	8.6	5823	1.4	104.41	55.0						
	9.4	5362	1.6	96.13	55.0						
	10.4	4821	1.7	86.43	55.0						
	11.4	4413	1.9	79.13	55.0						
	12.6	3982	2.1	71.40	55.0						
	14.3	3515	2.4	63.02	55.0						
	15.2	3305	2.5	59.26	55.0						
	16.8	2993	2.8	53.66	55.0						
	6.8	7255	1.1	205.73	55.0				A/F 903 132S4A / 132S4B	236	144
	7.5	6547	1.2	185.64	55.0						
	9.1	5434	1.5	154.07	55.0						
	10.0	4917	1.6	139.41	55.0						
	10.9	4527	1.8	128.36	55.0						
	12.1	4085	2.0	115.83	55.0						
	13.4	3682	2.2	104.41	55.0						
	14.6	3390	2.4	96.13	55.0						
	16.2	3048	2.6	86.43	55.0						
	17.7	2791	2.9	79.13	55.0						
	13.6	3468	1.8	205.73	55.0	A/F 903 132S2B / 132S2C	236	144			
	15.1	3129	1.9	185.64	55.0						
	18.2	2597	2.3	154.07	55.0						
	20.1	2350	2.6	139.41	55.0						
	21.8	2164	2.8	128.36	55.0						
	7.6	6623	0.8	118.75	30.0	A/F 703 132M6B	153	142			
	8.3	6049	0.9	108.46	30.0						
	9.0	5599	0.9	100.38	30.0						
	10.0	5017	1.0	89.95	30.0						
	10.8	4649	1.1	83.35	30.0						
	12.2	4111	1.3	73.70	30.0						
	13.4	3754	1.4	67.31	30.0						
	16.1	3109	1.7	55.75	30.0						
	19.7	2547	2.1	45.67	30.0						
	8.1	6105	0.8	173.11	30.0				A/F 703 132S4A / 132S4B	153	142
	9.0	5483	0.9	155.48	30.0						
	9.7	5112	1.0	144.94	30.0						
	10.9	4526	1.1	128.35	30.0						
	11.8	4188	1.2	118.75	30.0						
12.9	3825	1.3	108.46	30.0							
13.9	3540	1.4	100.38	30.0							
15.6	3172	1.6	89.95	30.0							
16.8	2939	1.7	83.35	30.0							
19.0	2599	1.9	73.70	30.0							
20.8	2374	2.1	67.31	30.0							
25.1	1966	2.5	55.75	30.0							
10.8	4385	0.9	260.15	30.0	A/F 703 132S2B / 132S2C	153	142				
12.1	3900	1.0	231.34	30.0							
13.5	3503	1.1	207.78	30.0							
14.8	3195	1.2	189.54	30.0							
16.2	2918	1.3	173.11	30.0							
18.0	2621	1.4	155.48	30.0							
19.3	2443	1.6	144.94	30.0							
21.8	2164	1.8	128.35	30.0							
23.6	2002	1.9	118.75	30.0							
25.8	1828	2.1	108.46	30.0							
27.9	1692	2.2	100.38	30.0							
31.1	1516	2.5	89.95	30.0							
33.6	1405	2.7	83.35	30.0							
20.1	2529	2.1	44.67	30.0				A/F 702 132M6B	153	142	
24.6	2072	2.5	36.60	30.0							
26.9	1893	2.8	33.43	30.0							
115.4	448	2.3	7.80	6.0	A/F 701 132M6B	100	140				
142.2	364	2.6	6.33	6.0							
170.1	304	3.0	5.29	6.0							



P ₁ [kW]	n ₂ [Min ⁻¹]	M ₂ [Nm]	f _B	i _{ges}	FR (a) [kN]	Tip / Type / Typ / Tipo / Type / Tipo IE2 / IE3	 Kg ~	 mm				
5.50	10.7	4706	0.8	84.37	22.0	A/F 603 132M6B	124	138				
	11.3	4461	0.8	79.98	22.0							
	12.9	3897	0.9	69.87	22.0							
	16.1	3109	1.2	55.75	22.0							
	11.6	4268	0.8	121.02	22.0	A/F 603 132S4A / 132S4B	124	138				
	14.0	3534	1.0	100.21	22.0							
	15.0	3301	1.1	93.60	22.0							
	16.6	2975	1.2	84.37	22.0							
	17.5	2821	1.2	79.98	22.0							
	20.0	2464	1.4	69.87	22.0							
	25.1	1966	1.8	55.75	22.0							
		14.4	3276	0.8	194.31				22.0	A/F 603 132S2B / 132S2C	124	138
15.5		3053	0.9	181.13	22.0							
17.4		2712	1.0	160.90	22.0							
19.5		2420	1.1	143.57	22.0							
20.9		2263	1.2	134.25	22.0							
23.1		2040	1.3	121.02	22.0							
27.9		1689	1.6	100.21	22.0							
29.9		1578	1.7	93.60	22.0							
33.2		1422	1.9	84.37	22.0							
35.0		1348	2.0	79.98	22.0							
40.1		1178	2.3	69.87	22.0							
50.2		940	2.8	55.75	22.0							
		17.7	2883	1.2	50.91	22.0	A/F 602 132M6B	124	138			
		19.9	2563	1.4	45.27	22.0						
	22.1	2311	1.5	40.81	22.0							
	23.7	2152	1.4	38.00	22.0							
	26.6	1913	1.8	33.79	22.0							
	29.7	1719	2.0	30.35	22.0							
	31.7	1606	2.2	28.36	22.0							
	35.2	1448	2.4	25.57	22.0							
	38.0	1340	2.6	23.66	22.0							
	42.5	1199	2.8	21.17	22.0							
	45.9	1109	3.0	19.59	22.0							
		27.5	1834	1.8	50.91	22.0				A/F 602 132S4A / 132S4B	124	138
		30.9	1630	2.0	45.27	22.0						
34.3		1470	2.2	40.81	22.0							
36.8		1369	2.0	38.00	22.0							
41.4		1217	2.6	33.79	22.0							
46.1		1093	2.9	30.35	22.0							
55.0	889	2.8	50.91	22.0	A/F 602 132S2B / 132S2C	124	138					
	108.4	477	1.4	8.30	5.0	A/F 601 132M6B	89	136				
	120.8	428	1.6	7.45	5.0							
	146.3	354	1.9	6.15	5.0							
	173.1	299	2.2	5.20	5.0							
	187.1	277	2.4	4.81	5.0							
	210.3	246	2.6	4.28	5.0							
	246.6	210	3.0	3.65	5.0							
	168.7	305	2.1	8.30	5.0	A/F 601 132S4A / 132S4B	89	136				
	187.9	274	2.4	7.45	5.0							
	227.6	226	2.8	6.15	5.0							
24.9	1982	0.8	56.21	18.0	A/F 503 132S4A / 132S4B	97	134					
	28.6	1649	0.8	97.80	18.0	A/F 503 132S2B / 132S2C	97	134				
	32.8	1438	1.0	85.33	18.0							
	35.6	1326	1.0	78.64	18.0							
	39.3	1201	1.1	71.27	18.0							
	49.8	948	1.3	56.21	18.0							



P ₁ [kW]	n ₂ [Min ⁻¹]	M ₂ [Nm]	f _B	i _{ges}	FR (a) [kN]	Tip / Type / Typ / Tipo / Type / Tipo IE2 / IE3	 Kg ~	 mm
5.50	23.0	2220	0.8	39.21	18.0	A/F 502 132M6B	97	134
	25.8	1972	0.9	34.83	18.0			
	28.5	1788	0.9	31.57	18.0			
	31.8	1600	1.0	28.26	17.8			
	33.4	1528	1.1	26.98	17.7			
	38.9	1310	1.3	23.14	17.2			
	41.5	1228	1.4	21.69	17.0			
	45.8	1113	1.5	19.66	16.7			
	47.8	1065	1.5	18.81	16.6			
	53.4	955	1.6	16.86	16.2			
	59.5	857	1.8	15.13	15.8			
	65.6	776	1.9	13.71	15.4			
	80.4	634	1.8	11.20	14.7			
	99.9	510	1.9	9.01	13.9			
	110.3	462	1.8	8.16	13.6			
	119.2	428	2.0	7.55	13.3			
	148.3	344	2.1	6.07	12.5			
	163.6	311	2.4	5.50	12.2			
	28.7	1757	0.9	48.77	18.0	A/F 502 132S4A / 132S4B	97	134
	32.3	1560	1.0	43.32	18.0			
	35.7	1412	1.1	39.21	18.0			
	40.2	1254	1.3	34.83	18.0			
	44.3	1137	1.4	31.57	18.0			
	49.5	1018	1.6	28.26	17.8			
	51.9	972	1.6	26.98	17.7			
	60.5	833	1.9	23.14	17.2			
	64.5	781	2.0	21.69	17.0			
	71.2	708	2.3	19.66	16.7			
	74.4	677	2.2	18.81	16.6			
	83.0	607	2.5	16.86	16.2			
	92.5	545	2.8	15.13	15.8			
	102.1	494	2.8	13.71	15.4			
	125.0	403	2.7	11.20	14.7			
	155.4	325	2.8	9.01	13.9			
	171.6	294	2.7	8.16	13.6			
	185.4	272	2.9	7.55	13.3			
	57.4	852	1.4	48.77	18.0	A/F 502 132S2B / 132S2C	97	134
	64.6	757	1.6	43.32	18.0			
	71.4	685	1.8	39.21	18.0			
	80.4	608	2.0	34.83	18.0			
	88.7	551	2.2	31.57	18.0			
	99.1	494	2.5	28.26	17.8			
	103.8	471	2.6	26.98	17.7			
	121.0	404	3.0	23.14	17.2			
	118.4	437	0.8	7.60	4.0	A/F 501 132M6B	72	132
	145.9	355	1.0	6.17	4.0			
	160.1	323	1.1	5.62	4.0			
	190.3	272	1.2	4.73	4.0			
221.7	233	1.4	4.06	4.0				
238.1	217	1.5	3.78	3.9				
272.7	190	1.7	3.30	3.8				
348.8	148	2.0	2.58	3.5				
456.9	113	2.1	1.97	3.3				
616.4	84	2.8	1.46	3.0				
681.8	76	2.8	1.32	2.9				
163.6	315	1.1	8.56	4.0	A/F 501 132S4A / 132S4B			
184.2	279	1.3	7.60	4.0				
226.9	227	1.5	6.17	4.0				
249.1	207	1.6	5.62	4.0				
296.0	174	1.8	4.73	4.0				
344.8	149	2.1	4.06	4.0				
370.4	139	2.2	3.78	3.9				
424.2	121	2.6	3.30	3.8				
542.6	95	3.0	2.58	3.5				
327.1	155	1.7	8.56	4.0		A/F 501 132S2B / 132S2C	72	132
368.4	138	1.9	7.60	4.0				
453.8	112	2.3	6.17	4.0				
498.2	102	2.5	5.62	4.0				
592.0	86	2.8	4.73	4.0				



P₁ [kW]	n₂ [Min ⁻¹]	M₂ [Nm]	f_B	i_{ges}	FR (a) [kN]	Tip / Type / Typ / Tipo / Type / Tipo IE2 / IE3	kg ~	mm			
5.50	45.1	1129	0.8	19.94	12.0	A/F 402 132M6B	80	130			
	51.8	984	0.9	17.37	12.0						
	56.2	907	0.9	16.01	12.0						
	62.1	821	0.9	14.50	11.9						
	72.3	704	1.0	12.44	11.6						
	78.5	649	1.1	11.46	11.4						
	97.8	521	1.2	9.20	10.9						
	108.0	472	1.3	8.33	10.7						
	124.7	409	1.4	7.22	10.4						
	155.2	328	1.8	5.80	9.8						
	171.4	297	1.8	5.25	9.6						
	55.3	911	0.9	25.30	12.0				A/F 402 132S4A / 132S4B	80	130
	61.1	825	1.0	22.91	12.0						
	70.2	718	1.2	19.94	12.0						
	80.6	626	1.3	17.37	12.0						
	87.4	577	1.4	16.01	12.0						
	96.6	522	1.3	14.50	11.9						
	112.5	448	1.6	12.44	11.6						
	122.2	413	1.6	11.46	11.4						
	152.2	331	1.8	9.20	10.9						
	168.1	300	2.0	8.33	10.7						
	193.9	260	2.1	7.22	10.4						
	241.4	209	2.6	5.80	9.8						
	266.7	189	2.6	5.25	9.6						
	88.9	550	1.2	31.50	12.0	A/F 402 132S2B / 132S2C	80	130			
	110.7	442	1.5	25.30	12.0						
	122.2	400	1.6	22.91	12.0						
	140.4	348	1.9	19.94	12.0						
	161.2	303	2.1	17.37	12.0						
	174.9	280	2.2	16.01	12.0						
193.1	253	2.1	14.50	11.9							
225.1	217	2.4	12.44	11.6							
244.3	200	2.5	11.46	11.4							
304.3	161	2.8	9.20	10.9							
7.50	6.5	10603	0.8	139.41	55.0	A/F 903 160M6B / 160M6C	280	144			
	7.0	9762	0.9	128.36	55.0						
	7.8	8810	1.0	115.83	55.0						
	8.6	7941	1.1	104.41	55.0						
	9.4	7311	1.1	96.13	55.0						
	10.4	6573	1.3	86.43	55.0						
	11.4	6018	1.4	79.13	55.0						
	12.6	5430	1.5	71.40	55.0						
	14.3	4793	1.8	63.02	55.0						
	15.2	4507	1.9	59.26	55.0						
	16.8	4081	2.1	53.66	55.0						
	18.6	3689	2.3	48.50	55.0						
	6.8	9894	0.8	205.73	55.0				A/F 903 132M4C / 132M4D	236	144
	7.5	8928	0.9	185.64	55.0						
	9.1	7409	1.1	154.07	55.0						
	10.0	6704	1.2	139.41	55.0						
	10.9	6173	1.3	128.36	55.0						
	12.1	5570	1.4	115.83	55.0						
	13.4	5021	1.6	104.41	55.0						
	14.6	4623	1.7	96.13	55.0						
	16.2	4157	1.9	86.43	55.0						
	17.7	3805	2.1	79.13	55.0						
	19.6	3434	2.3	71.40	55.0						
	22.2	3031	2.6	63.02	55.0						
	23.6	2850	2.8	59.26	55.0						
	13.6	4729	1.3	205.73	55.0	A/F 903 132S2C / 132S2D	236	144			
	15.1	4267	1.4	185.64	55.0						
	18.2	3542	1.7	154.07	55.0						
	20.1	3205	1.9	139.41	55.0						
	21.8	2951	2.1	128.36	55.0						
24.2	2663	2.3	115.83	55.0							
26.8	2400	2.5	104.41	55.0							
29.1	2210	2.8	96.13	55.0							

P ₁ [kW]	n ₂ [Min ⁻¹]	M ₂ [Nm]	f _B	i _{ges}	FR (a) [kN]	Tip / Type / Typ / Tipo / Type / Tipo IE2 / IE3	 Kg ~	 mm
7.50	10.0	6841	0.8	89.95	30.0	A/F 703 160M6B / 160M6C	189	142
	10.8	6339	0.8	83.35	30.0			
	12.2	5605	0.9	73.70	30.0			
	13.4	5119	1.0	67.31	30.0			
	16.1	4240	1.2	55.75	30.0			
	19.7	3473	1.5	45.67	30.0			
	10.9	6172	0.8	128.35	30.0	A/F 703 132M4C / 132M4D	153	142
	11.8	5711	0.9	118.75	30.0			
	12.9	5216	1.0	108.46	30.0			
	13.9	4827	1.0	100.38	30.0			
	15.6	4326	1.2	89.95	30.0			
	16.8	4008	1.2	83.35	30.0			
	19.0	3544	1.4	73.70	30.0			
	20.8	3237	1.5	67.31	30.0			
	25.1	2681	1.9	55.75	30.0			
	30.7	2196	2.3	45.67	30.0			
	13.5	4776	0.8	207.78	30.0	A/F 703 132S2C / 132S2D	153	142
	14.8	4357	0.9	189.54	30.0			
	16.2	3979	1.0	173.11	30.0			
	18.0	3574	1.1	155.48	30.0			
	19.3	3332	1.1	144.94	30.0			
	21.8	2950	1.3	128.35	30.0			
	23.6	2730	1.4	118.75	30.0			
	25.8	2493	1.5	108.46	30.0			
	27.9	2307	1.6	100.38	30.0			
	31.1	2068	1.8	89.95	30.0			
	33.6	1916	2.0	83.35	30.0			
	38.0	1694	2.2	73.70	30.0			
	41.6	1547	2.5	67.31	30.0			
	50.2	1282	3.0	55.75	30.0			
	20.1	3449	1.5	44.67	30.0	A/F 702 160M6B / 160M6C	189	142
	24.6	2826	1.9	36.60	30.0			
	26.9	2581	2.0	33.43	30.0			
	29.7	2337	2.2	30.27	30.0			
	32.3	2152	2.4	27.87	30.0			
	36.3	1915	2.7	24.80	30.0			
	39.4	1764	3.0	22.84	30.0			
	31.3	2194	2.3	44.67	30.0	A/F 702 132M4C / 132M4D	153	142
	38.3	1798	2.8	36.60	30.0			
	41.9	1642	3.0	33.43	30.0			
	115.4	611	1.7	7.80	6.0	A/F 701 160M6B / 160M6C	136	140
	142.2	496	1.9	6.33	6.0			
170.1	415	2.2	5.29	6.0				
184.8	382	2.4	4.87	6.0				
215.3	328	2.7	4.18	6.0				
179.5	391	2.6	7.80	6.0	A/F 701 132M4C / 132M4D	100	140	
221.2	317	2.8	6.33	6.0				
16.1	4240	0.9	55.75	22.0	A/F 603 160M6B / 160M6C	160	138	
15.0	4501	0.8	93.60	22.0	A/F 603 132M4C / 132M4D	124	138	
16.6	4057	0.9	84.37	22.0				
17.5	3846	0.9	79.98	22.0				
20.0	3360	1.0	69.87	22.0				
25.1	2681	1.3	55.75	22.0				
19.5	3300	0.8	143.57	22.0	A/F 603 132S2C / 132S2D	124	138	
20.9	3086	0.9	134.25	22.0				
23.1	2782	1.0	121.02	22.0				
27.9	2304	1.2	100.21	22.0				
29.9	2152	1.2	93.60	22.0				
33.2	1939	1.4	84.37	22.0				
35.0	1839	1.4	79.98	22.0				
40.1	1606	1.7	69.87	22.0				
50.2	1282	2.1	55.75	22.0				



P ₁ [kW]	n ₂ [Min ⁻¹]	M ₂ [Nm]	f _B	i _{ges}	FR (a) [kN]	Tip / Type / Typ / Tipo / Type / Tipo IE2 / IE3	 Kg ~	 mm			
7.50	19.9	3495	1.0	45.27	22.0	A/F 602 160M6B / 160M6C	160	138			
	22.1	3151	1.1	40.81	22.0						
	26.6	2609	1.3	33.79	22.0						
	29.7	2343	1.4	30.35	22.0						
	31.7	2190	1.6	28.36	22.0						
	35.2	1974	1.8	25.57	22.0						
	38.0	1827	1.9	23.66	22.0						
	42.5	1635	2.1	21.17	22.0						
	45.9	1513	2.2	19.59	22.0						
	51.1	1359	2.5	17.60	22.0						
	56.7	1225	2.7	15.87	22.0						
	27.5	2500	1.3	50.91	22.0				A/F 602 132M4C / 132M4D	124	138
	30.9	2223	1.5	45.27	22.0						
	34.3	2004	1.6	40.81	22.0						
	36.8	1866	1.5	38.00	22.0						
	41.4	1660	1.9	33.79	22.0						
	46.1	1491	2.1	30.35	22.0						
	49.4	1393	2.4	28.36	22.0						
	54.8	1256	2.6	25.57	22.0						
	59.2	1162	2.8	23.66	22.0						
	55.0	1213	2.1	50.91	22.0	A/F 602 132S2C / 132S2D	124	138			
	61.9	1078	2.3	45.27	22.0						
	68.6	972	2.6	40.81	22.0						
	73.7	905	2.4	38.00	22.0						
	82.9	805	3.0	33.79	22.0						
	108.4	651	1.0	8.30	5.0	A/F 601 160M6B / 160M6C	125	136			
	120.8	584	1.2	7.45	5.0						
	146.3	482	1.4	6.15	5.0						
	173.1	408	1.6	5.20	5.0						
	187.1	377	1.7	4.81	5.0						
	210.3	336	1.9	4.28	5.0						
	246.6	286	2.2	3.65	5.0						
	278.6	253	2.5	3.23	5.0						
	368.9	191	3.0	2.44	5.0						
	450.0	157	3.0	2.00	5.0						
	168.7	416	1.6	8.30	5.0	A/F 601 132M4C / 132M4D	89	136			
	187.9	374	1.7	7.45	5.0						
	227.6	308	2.1	6.15	5.0						
	269.2	261	2.4	5.20	5.0						
	291.1	241	2.6	4.81	5.0						
	327.1	215	2.8	4.28	5.0						
	337.3	205	2.4	8.30	5.0	A/F 601 132S2C / 132S2D	89	136			
375.8	184	2.7	7.45	5.0							
35.6	1808	0.8	78.64	18.0	A/F 503 132S2C / 132S2D	97	134				
39.3	1638	0.8	71.27	18.0							
49.8	1292	0.9	56.21	18.0							
33.4	2083	0.8	26.98	16.1	A/F 502 160M6B / 160M6C	133	134				
38.9	1787	0.9	23.14	15.9							
41.5	1675	1.0	21.69	15.8							
45.8	1518	1.1	19.66	15.5							
47.8	1452	1.1	18.81	15.4							
53.4	1302	1.2	16.86	15.2							
59.5	1168	1.3	15.13	14.9							
65.6	1059	1.4	13.71	14.6							
80.4	865	1.3	11.20	14.0							
99.9	696	1.4	9.01	13.4							
110.3	630	1.3	8.16	13.1							
119.2	583	1.4	7.55	12.8							
148.3	469	1.6	6.07	12.1							
163.6	425	1.7	5.50	12.1							



P ₁ [kW]	n ₂ [Min ⁻¹]	M ₂ [Nm]	f _B	i _{ges}	FR (a) [kN]	Tip / Type / Typ / Tipo / Type / Tipo IE2 / IE3	 Kg ~	 mm				
7.50	32.3	2128	0.8	43.32	18.0	A/F 502 132M4C / 132M4D	97	134				
	35.7	1926	0.8	39.21	18.0							
	40.2	1711	0.9	34.83	16.3							
	44.3	1551	1.0	31.57	16.3							
	49.5	1388	1.2	28.26	16.2							
	51.9	1325	1.2	26.98	16.1							
	60.5	1137	1.4	23.14	15.9							
	64.5	1065	1.5	21.69	15.8							
	71.2	966	1.7	19.66	15.5							
	74.4	924	1.6	18.81	15.4							
	83.0	828	1.8	16.86	15.2							
	92.5	743	2.0	15.13	14.9							
	102.1	673	2.1	13.71	14.6							
	125.0	550	2.0	11.20	14.0							
	155.4	443	2.0	9.01	13.4							
171.6	401	2.0	8.16	13.1								
185.4	371	2.2	7.55	12.8								
230.6	298	2.3	6.07	12.1								
254.5	270	2.6	5.50	12.1								
	57.4	1162	1.0	48.77	18.0	A/F 502 132S2C / 132S2D	97	134				
	64.6	1032	1.2	43.32	18.0							
	71.4	934	1.3	39.21	18.0							
	80.4	830	1.5	34.83	16.3							
	88.7	752	1.6	31.57	16.3							
	99.1	673	1.8	28.26	16.2							
	103.8	643	1.9	26.98	16.1							
	121.0	551	2.2	23.14	15.9							
	129.1	517	2.4	21.69	15.8							
	142.4	468	2.6	19.66	15.5							
	148.9	448	2.5	18.81	15.4							
	166.1	402	2.8	16.86	15.2							
		163.6	429	0.8	8.56				4.0	A/F 501 132M4C / 132M4D	72	132
		184.2	381	0.9	7.60				4.0			
		226.9	309	1.1	6.17				4.0			
249.1		282	1.2	5.62	4.0							
296.0		237	1.3	4.73	3.9							
344.8		204	1.6	4.06	3.8							
370.4		190	1.6	3.78	3.7							
424.2		165	1.9	3.30	3.6							
542.6		129	2.2	2.58	3.4							
710.7		99	2.3	1.97	3.2							
958.9		73	3.0	1.46	3.0							
1060.6		66	3.0	1.32	2.9							
	327.1	211	1.3	8.56	4.0	A/F 501 132S2C / 132S2D	72	132				
	368.4	188	1.4	7.60	4.0							
	453.8	152	1.7	6.17	4.0							
	498.2	139	1.8	5.62	4.0							
	592.0	117	2.1	4.73	3.9							
	689.7	100	2.4	4.06	3.8							
	740.7	93	2.5	3.78	3.7							
	848.5	81	2.9	3.30	3.6							
	61.1	1125	0.8	22.91	12.0	A/F 402 132M4C / 132M4D	80	130				
	70.2	979	0.9	19.94	12.0							
	80.6	853	1.0	17.37	10.8							
	87.4	786	1.0	16.01	10.8							
	96.6	712	1.0	14.50	10.8							
	112.5	611	1.1	12.44	10.6							
	122.2	563	1.2	11.46	10.5							
	152.2	452	1.3	9.20	10.2							
	168.1	409	1.5	8.33	10.1							
	193.9	355	1.6	7.22	9.8							
	241.4	285	1.9	5.80	9.4							
	266.7	258	1.9	5.25	9.2							

P ₁ [kW]	n ₂ [Min ⁻¹]	M ₂ [Nm]	f _B	i _{ges}	FR (a) [kN]	Tip / Type / Typ / Tipo / Type / Tipo IE2 / IE3	 Kg ~	 mm		
7.50	88.9	750	0.9	31.50	12.0	A/F 402 132S2C / 132S2D	80	130		
	110.7	603	1.1	25.30	12.0					
	122.2	546	1.2	22.91	12.0					
	140.4	475	1.4	19.94	12.0					
	161.2	414	1.5	17.37	10.8					
	174.9	381	1.6	16.01	10.8					
	193.1	345	1.5	14.50	10.8					
	225.1	296	1.8	12.44	10.6					
	244.3	273	1.8	11.46	10.5					
	304.3	219	2.1	9.20	10.2					
	336.1	198	2.3	8.33	10.1					
	387.8	172	2.4	7.22	9.8					
	482.8	138	3.0	5.80	9.4					
	533.3	125	3.0	5.25	9.2					
9.20	7.8	10806	0.8	115.83	55.0	A/F 903 160M6	280	144		
	8.6	9741	0.9	104.41	55.0					
	9.4	8968	0.9	96.13	55.0					
	10.4	8063	1.0	86.43	55.0					
	11.4	7382	1.1	79.13	55.0					
	12.6	6661	1.3	71.40	55.0					
	14.3	5879	1.4	63.02	55.0					
	15.2	5529	1.5	59.26	55.0					
	16.8	5006	1.7	53.66	55.0					
	18.6	4525	1.9	48.50	55.0					
	9.1	9089	0.9	154.07	-	A/F 903 132M4	236	144		
	10.0	8224	1.0	139.41	55.0					
	10.9	7572	1.1	128.36	55.0					
	12.1	6833	1.2	115.83	55.0					
	13.4	6159	1.3	104.41	55.0					
	14.6	5671	1.4	96.13	55.0					
	16.2	5099	1.6	86.43	55.0					
	17.7	4668	1.7	79.13	55.0					
	19.6	4212	1.9	71.40	55.0					
	22.2	3718	2.2	63.02	55.0					
	23.6	3496	2.3	59.26	55.0					
	26.1	3165	2.5	53.66	55.0					
	13.6	5801	1.0	205.73	55.0	A/F 903 132M2	236	144		
	15.1	5235	1.2	185.64	55.0					
	18.2	4344	1.4	154.07	55.0					
	20.1	3931	1.5	139.41	55.0					
	21.8	3619	1.7	128.36	55.0					
	24.2	3266	1.9	115.83	55.0					
	26.8	2944	2.1	104.41	55.0					
	29.1	2711	2.2	96.13	55.0					
	32.4	2437	2.5	86.43	55.0					
	35.4	2231	2.7	79.13	55.0					
	39.2	2013	3.0	71.40	55.0					
	12.2	6876	0.8	73.70	30.0	A/F 703 160M6	189	142		
	13.4	6280	0.8	67.31	30.0					
	16.1	5201	1.0	55.75	30.0					
19.7	4261	1.2	45.67	30.0						
12.9	6398	0.8	108.46	-	A/F 703 132M4	153	142			
13.9	5922	0.8	100.38	-						
15.6	5306	0.9	89.95	30.0						
16.8	4917	1.0	83.35	30.0						
19.0	4348	1.2	73.70	30.0						
20.8	3971	1.3	67.31	30.0						
25.1	3289	1.5	55.75	30.0						
30.7	2694	1.9	45.67	30.0						



P ₁ [kW]	n ₂ [Min ⁻¹]	M ₂ [Nm]	f _B	i _{ges}	FR (a) [kN]	Tip / Type / Typ / Tipo / Type / Tipo IE2 / IE3	 Kg ~	 mm
9.20	16.2	4881	0.8	173.11	30.0	A/F 703 132M2	153	142
	18.0	4384	0.9	155.48	30.0			
	19.3	4087	0.9	144.94	30.0			
	21.8	3619	1.0	128.35	30.0			
	23.6	3348	1.1	118.75	30.0			
	25.8	3058	1.2	108.46	30.0			
	27.9	2830	1.3	100.38	30.0			
	31.1	2536	1.5	89.95	30.0			
	33.6	2350	1.6	83.35	30.0			
	38.0	2078	1.8	73.70	30.0			
41.6	1898	2.0	67.31	30.0				
50.2	1572	2.4	55.75	30.0				
61.3	1288	3.0	45.67	30.0				
	20.1	4231	1.2	44.67	30.0	A/F 702 160M6	189	142
	24.6	3467	1.5	36.60	30.0			
	26.9	3166	1.7	33.43	30.0			
	29.7	2867	1.8	30.27	30.0			
	32.3	2640	2.0	27.87	30.0			
	36.3	2349	2.2	24.80	30.0			
	39.4	2163	2.4	22.84	30.0			
	43.1	1976	2.7	20.86	30.0			
45.9	1856	2.8	19.60	30.0				
	31.3	2691	1.9	44.67	30.0	A/F 702 132M4	153	142
	38.3	2205	2.3	36.60	30.0			
	41.9	2014	2.5	33.43	30.0			
	46.3	1824	2.7	30.27	30.0			
50.2	1679	3.0	27.87	30.0				
62.7	1305	2.9	44.67	30.0	A/F 702 132M2	153	142	
	115.4	750	1.4	7.80	6.0	A/F 701 160M6	136	140
	142.2	609	1.6	6.33	6.0			
	170.1	509	1.8	5.29	6.0			
	184.8	468	2.0	4.87	6.0			
	215.3	402	2.2	4.18	6.0			
	247.9	349	2.6	3.63	6.0			
	282.1	307	2.8	3.19	6.0			
	300.0	288	2.9	3.00	6.0			
	179.5	480	2.1	7.80	6.0	A/F 701 132M4	100	140
	221.2	389	2.3	6.33	6.0			
	264.7	325	2.7	5.29	6.0			
	287.5	300	2.9	4.87	6.0			
	20.0	4122	0.8	69.87	-	A/F 603 132M4	124	138
	25.1	3289	1.1	55.75	22.0			
	23.1	3412	0.8	121.02	22.0	A/F 603 132M2	124	138
	27.9	2826	0.9	100.21	22.0			
	29.9	2639	1.0	93.60	22.0			
	33.2	2379	1.1	84.37	22.0			
	35.0	2255	1.2	79.98	22.0			
	40.1	1970	1.4	69.87	22.0			
50.2	1572	1.7	55.75	22.0				
	19.9	4288	0.8	45.27	22.0	A/F 602 160M6	160	138
	22.1	3865	0.9	40.81	22.0			
	23.7	3599	0.8	38.00	22.0			
	26.6	3200	1.0	33.79	22.0			
	29.7	2875	1.2	30.35	22.0			
	31.7	2686	1.3	28.36	22.0			
	35.2	2422	1.4	25.57	22.0			
	38.0	2241	1.5	23.66	22.0			
	42.5	2005	1.7	21.17	22.0			
	45.9	1855	1.8	19.59	22.0			
	51.1	1667	2.0	17.60	21.9			
	56.7	1503	2.2	15.87	21.4			
	68.5	1245	2.6	13.14	20.5			
	82.5	1033	3.0	10.91	19.1			

P ₁ [kW]	n ₂ [Min ⁻¹]	M ₂ [Nm]	f _B	i _{ges}	FR (a) [kN]	Tip / Type / Typ / Tipo / Type / Tipo IE2 / IE3	Kg ~	mm
9.20	27.5	3067	1.1	50.91	22.0	A/F 602 132M4	124	138
	30.9	2727	1.2	45.27	22.0			
	34.3	2459	1.3	40.81	22.0			
	36.8	2289	1.2	38.00	22.0			
	41.4	2036	1.6	33.79	22.0			
	46.1	1828	1.8	30.35	22.0			
	49.4	1709	1.9	28.36	22.0			
	54.8	1541	2.1	25.57	22.0			
	59.2	1425	2.3	23.66	22.0			
	66.1	1275	2.5	21.17	22.0			
71.5	1180	2.7	19.59	22.0				
79.5	1060	3.0	17.60	21.9				
	55.0	1488	1.7	50.91	22.0	A/F 602 132M2	124	138
	61.9	1323	1.9	45.27	22.0			
	68.6	1192	2.1	40.81	22.0			
	73.7	1110	1.9	38.00	22.0			
	82.9	987	2.5	33.79	22.0			
	92.3	887	2.7	30.35	22.0			
	98.7	829	3.0	28.36	22.0			
	108.4	798	0.9	8.30	5.0	A/F 601 160M6	125	136
	120.8	716	1.0	7.45	5.0			
	146.3	591	1.1	6.15	5.0			
	173.1	500	1.3	5.20	5.0			
	187.1	463	1.4	4.81	5.0			
	210.3	412	1.6	4.28	5.0			
	246.6	351	1.8	3.65	4.9			
	278.6	311	2.0	3.23	4.7			
	368.9	235	2.5	2.44	4.4			
	450.0	192	2.5	2.00	4.2			
	168.7	510	1.3	8.30	5.0	A/F 601 132M4	89	136
	187.9	458	1.4	7.45	5.0			
	227.6	378	1.7	6.15	5.0			
	269.2	320	1.9	5.20	5.0			
	291.1	296	2.1	4.81	5.0			
	327.1	263	2.3	4.28	5.0			
	383.6	224	2.7	3.65	4.9			
	433.4	199	3.0	3.23	4.7			
	337.3	251	2.0	8.30	5.0	A/F 601 132M2	89	136
	375.8	226	2.2	7.45	5.0			
	455.3	186	2.6	6.15	5.0			
	538.5	157	3.0	5.20	5.0			
	49.8	1585	0.8	56.21	18.0	A/F 503 132M2	97	134
	38.9	2192	0.8	23.14	14.7	A/F 502 160M6	133	134
	41.5	2054	0.8	21.69	14.7			
	45.8	1862	0.9	19.66	14.6			
	47.8	1782	0.9	18.81	14.5			
	53.4	1597	1.0	16.86	14.3			
	59.5	1433	1.1	15.13	14.1			
	65.6	1299	1.1	13.71	13.9			
	80.4	1061	1.1	11.20	13.5			
	99.9	853	1.1	9.01	12.9			
	110.3	773	1.1	8.16	12.7			
	119.2	715	1.2	7.55	12.4			
	148.3	575	1.3	6.07	11.8			
	163.6	521	1.4	5.50	11.6			

P ₁ [kW]	n ₂ [Min ⁻¹]	M ₂ [Nm]	f _B	i _{ges}	FR (a) [kN]	Tip / Type / Typ / Tipo / Type / Tipo IE2 / IE3	 Kg ~	 mm			
9.20	40.2	2098	0.8	34.83	-	A/F 502 132M4	97	134			
	44.3	1902	0.8	31.57	-						
	49.5	1703	0.9	28.26	14.8						
	51.9	1625	1.0	26.98	14.8						
	60.5	1394	1.1	23.14	14.7						
	64.5	1307	1.2	21.69	14.7						
	71.2	1184	1.4	19.66	14.6						
	74.4	1133	1.3	18.81	14.5						
	83.0	1016	1.5	16.86	14.3						
	92.5	912	1.6	15.13	14.1						
	102.1	826	1.7	13.71	13.9						
	125.0	675	1.6	11.20	13.5						
	155.4	543	1.7	9.01	12.9						
	171.6	492	1.6	8.16	12.7						
	185.4	455	1.8	7.55	12.4						
	230.6	366	1.9	6.07	11.8						
	254.5	331	2.1	5.50	11.6						
	57.4	1425	0.9	48.77	14.8				A/F 502 132M2	97	134
	64.6	1266	1.0	43.32	14.8						
	71.4	1146	1.1	39.21	14.8						
	80.4	1018	1.2	34.83	14.8						
	88.7	922	1.3	31.57	14.8						
	99.1	826	1.5	28.26	14.8						
	103.8	788	1.5	26.98	14.8						
	121.0	676	1.8	23.14	14.7						
	129.1	634	1.9	21.69	14.7						
	142.4	574	2.1	19.66	14.6						
	148.9	550	2.1	18.81	14.5						
	166.1	493	2.3	16.86	14.3						
	185.1	442	2.6	15.13	14.1						
	204.2	401	2.7	13.71	13.9						
	250.0	327	2.6	11.20	13.5						
	310.8	263	2.6	9.01	12.9						
	343.1	238	2.5	8.16	12.7						
	370.9	221	2.8	7.55	12.4						
	461.3	177	3.0	6.07	11.8						
	221.7	390	0.9	4.06	3.6	A/F 501 160M6	108	132			
	238.1	363	0.9	3.78	3.5						
	272.7	317	1.0	3.30	3.5						
	348.8	248	1.2	2.58	3.3						
	456.9	189	1.3	1.97	3.1						
	616.4	140	1.6	1.46	2.9						
	681.8	127	1.7	1.32	2.8						
	226.9	379	0.9	6.17	3.7	A/F 501 132M4	72	132			
	249.1	346	1.0	5.62	3.7						
	296.0	291	1.1	4.73	3.6						
	344.8	250	1.3	4.06	3.6						
	370.4	232	1.3	3.78	3.5						
	424.2	203	1.5	3.30	3.5						
	542.6	159	1.8	2.58	3.3						
	710.7	121	1.9	1.97	3.1						
	958.9	90	2.5	1.46	2.9						
	1060.6	81	2.5	1.32	2.8						
	327.1	259	1.0	8.56	3.7	A/F 501 132M2	72	132			
	368.4	230	1.2	7.60	3.7						
	453.8	187	1.4	6.17	3.7						
	498.2	170	1.5	5.62	3.7						
	592.0	143	1.7	4.73	3.6						
	689.7	123	2.0	4.06	3.6						
	740.7	114	2.1	3.78	3.5						
	848.5	100	2.4	3.30	3.5						
	1085.3	78	2.7	2.58	3.3						
	1421.3	60	2.9	1.97	3.1						
	108.0	789	0.8	8.33	9.5	A/F 402 160M6	116	130			
	124.7	684	0.8	7.22	9.3						
	155.2	549	1.1	5.80	9.0						
	171.4	497	1.1	5.25	8.8						



P ₁ [kW]	n ₂ [Min ⁻¹]	M ₂ [Nm]	f _B	i _{ges}	FR (a) [kN]	Tip / Type / Typ / Tipo / Type / Tipo IE2 / IE3	 Kg ~	 mm
9.20	80.6	1046	0.8	17.37	-	A/F 402 132M4	80	130
	87.4	965	0.8	16.01	-			
	96.6	874	0.8	14.50	-			
	112.5	749	0.9	12.44	9.8			
	122.2	690	0.9	11.46	9.8			
	152.2	554	1.1	9.20	9.6			
	168.1	502	1.2	8.33	9.5			
	193.9	435	1.3	7.22	9.3			
	241.4	349	1.6	5.80	9.0			
	266.7	316	1.6	5.25	8.8			
	110.7	739	0.9	25.30	9.8	A/F 402 132M2	80	130
	122.2	669	1.0	22.91	9.8			
	140.4	583	1.1	19.94	9.8			
	161.2	508	1.2	17.37	9.8			
	174.9	468	1.3	16.01	9.8			
	193.1	424	1.3	14.50	9.8			
	225.1	364	1.5	12.44	9.8			
	244.3	335	1.5	11.46	9.8			
	304.3	269	1.7	9.20	9.6			
	336.1	243	1.9	8.33	9.5			
387.8	211	2.0	7.22	9.3				
482.8	169	2.5	5.80	9.0				
533.3	153	2.5	5.25	8.8				
11.0	9.4	10723	0.8	96.13	55.0	A/F 903 160L6B / 160L6D	280	144
	10.4	9641	0.9	86.43	55.0			
	11.4	8827	1.0	79.13	55.0			
	12.6	7965	1.1	71.40	55.0			
	14.3	7030	1.2	63.02	55.0			
	15.2	6610	1.3	59.26	55.0			
	16.8	5986	1.4	53.66	55.0			
	18.6	5410	1.6	48.50	55.0			
	10.0	9833	0.8	139.41	55.0	A/F 903 160M4C	280	144
	10.9	9054	0.9	128.36	55.0			
	12.1	8170	1.0	115.83	55.0			
	13.4	7364	1.1	104.41	55.0			
	14.6	6780	1.2	96.13	55.0			
	16.2	6096	1.3	86.43	55.0			
	17.7	5581	1.4	79.13	55.0			
	19.6	5036	1.6	71.40	55.0			
	22.2	4445	1.8	63.02	55.0			
	23.6	4180	1.9	59.26	55.0			
	26.1	3785	2.1	53.66	55.0			
	28.9	3421	2.3	48.50	55.0			
	13.6	6936	0.9	205.73	55.0	A/F 903 160M2B / 160M2C	280	144
	15.1	6259	1.0	185.64	55.0			
	18.2	5194	1.2	154.07	55.0			
	20.1	4700	1.3	139.41	55.0			
	21.8	4328	1.4	128.36	55.0			
	24.2	3905	1.6	115.83	55.0			
	26.8	3520	1.7	104.41	55.0			
	29.1	3241	1.9	96.13	55.0			
	32.4	2914	2.1	86.43	55.0			
	35.4	2668	2.3	79.13	55.0			
	39.2	2407	2.5	71.40	55.0			
	44.4	2125	2.9	63.02	55.0			
	47.2	1998	3.0	59.26	55.0			
	21.2	4810	1.7	42.47	55.0	A/F 902 160L6B / 160L6D	280	144
	23.5	4341	1.9	38.33	55.0			
	28.3	3602	2.3	31.81	55.0			
	34.1	2987	2.8	26.38	55.0			
	33.0	3059	2.6	42.47	55.0	A/F 902 160M4C	280	144
	36.5	2761	2.9	38.33	55.0			
	16.1	6219	0.8	55.75	30.0	A/F 703 160L6B / 160L6D	189	142
19.7	5094	1.0	45.67	30.0				



P₁ [kW]	n₂ [Min ⁻¹]	M₂ [Nm]	f_B	i_{ges}	FR (a) [kN]	Tip / Type / Typ / Tipo / Type / Tipo IE2 / IE3	Kg ~	mm
11.0	15.6	6344	0.8	89.95	30.0	A/F 703 160M4C	189	142
	16.8	5879	0.9	83.35	30.0			
	19.0	5198	1.0	73.70	30.0			
	20.8	4748	1.1	67.31	30.0			
	25.1	3932	1.3	55.75	30.0			
	30.7	3221	1.6	45.67	30.0			
	19.3	4887	0.8	144.94	30.0	A/F 703 160M2B / 160M2C	189	142
	21.8	4327	0.9	128.35	30.0			
	23.6	4004	0.9	118.75	30.0			
	25.8	3657	1.0	108.46	30.0			
	27.9	3384	1.1	100.38	30.0			
	31.1	3033	1.3	89.95	30.0			
	33.6	2810	1.4	83.35	30.0			
	38.0	2485	1.5	73.70	30.0			
	41.6	2269	1.7	67.31	30.0			
	50.2	1880	2.0	55.75	30.0			
	61.3	1540	2.5	45.67	30.0			
	20.1	5059	1.0	44.67	30.0	A/F 702 160L6B / 160L6D	189	142
	24.6	4145	1.3	36.60	30.0			
	26.9	3786	1.4	33.43	30.0			
	29.7	3428	1.5	30.27	30.0			
	32.3	3156	1.7	27.87	30.0			
	36.3	2809	1.9	24.80	30.0			
	39.4	2587	2.0	22.84	30.0			
	43.1	2362	2.2	20.86	30.0			
	45.9	2220	2.4	19.60	30.0			
	52.4	1946	2.6	17.18	30.0			
	63.9	1595	3.0	14.08	30.0			
	31.3	3218	1.6	44.67	30.0	A/F 702 160M4C	189	142
	38.3	2636	1.9	36.60	30.0			
	41.9	2408	2.1	33.43	30.0			
	46.3	2180	2.3	30.27	30.0			
	50.2	2008	2.5	27.87	30.0			
	56.5	1786	2.8	24.80	30.0			
	61.3	1645	3.0	22.84	30.0			
	62.7	1561	2.4	44.67	30.0	A/F 702 160M2B / 160M2C	189	142
76.5	1279	3.0	36.60	30.0				
115.4	897	1.2	7.80	6.0	A/F 701 160L6B / 160L6D	136	140	
142.2	728	1.3	6.33	6.0				
170.1	608	1.5	5.29	6.0				
184.8	560	1.6	4.87	6.0				
215.3	481	1.9	4.18	6.0				
247.9	417	2.1	3.63	6.0				
282.1	367	2.3	3.19	6.0				
300.0	345	2.4	3.00	6.0				
357.1	290	2.9	2.52	5.6				
179.5	574	1.7	7.80	6.0				A/F 701 160M4C
221.2	465	1.9	6.33	6.0				
264.7	389	2.3	5.29	6.0				
287.5	358	2.4	4.87	6.0				
334.9	307	2.8	4.18	6.0				
359.0	282	2.7	7.80	6.0	A/F 701 160M2B / 160M2C	136	140	
442.3	229	3.0	6.33	6.0				
25.1	3932	0.9	55.75	22.0	A/F 603 160M4C	160	138	
27.9	3379	0.8	100.21	22.0	A/F 603 160M2B / 160M2C	160	138	
29.9	3156	0.8	93.60	22.0				
33.2	2845	0.9	84.37	22.0				
35.0	2697	1.0	79.98	22.0				
40.1	2356	1.1	69.87	22.0				
50.2	1880	1.4	55.75	22.0				

P_1 [kW]	n_2 [Min ⁻¹]	M_2 [Nm]	f_B	i_{ges}	FR (a) [kN]	Tip / Type / Typ / Tipo / Type / Tipo IE2 / IE3	 Kg ~	 mm			
11.0	26.6	3827	0.9	33.79	22.0	A/F 602 160L6B / 160L6D	160	138			
	29.7	3437	1.0	30.35	22.0						
	31.7	3212	1.1	28.36	22.0						
	35.2	2896	1.2	25.57	22.0						
	38.0	2679	1.3	23.66	22.0						
	42.5	2397	1.4	21.17	21.7						
	45.9	2219	1.5	19.59	21.4						
	51.1	1993	1.7	17.60	21.1						
	56.7	1797	1.9	15.87	20.7						
	68.5	1488	2.2	13.14	19.9						
	82.5	1236	2.5	10.91	19.1						
	91.6	1113	2.6	9.83	18.7						
	110.6	922	2.8	8.14	17.0						
	144.2	707	3.0	6.24	16.1						
		30.9	3261	1.0	45.27				22.0	A/F 602 160M4C	160
		34.3	2940	1.1	40.81	22.0					
		41.4	2434	1.3	33.79	22.0					
		46.1	2186	1.5	30.35	22.0					
		49.4	2043	1.6	28.36	22.0					
		54.8	1842	1.8	25.57	22.0					
		59.2	1704	1.9	23.66	22.0					
		66.1	1525	2.1	21.17	21.7					
		71.5	1411	2.3	19.59	21.4					
		79.5	1268	2.5	17.60	21.1					
		88.2	1143	2.8	15.87	20.7					
		61.9	1582	1.6	45.27	22.0	A/F 602 160M2B / 160M2C	160	138		
		68.6	1426	1.8	40.81	22.0					
		82.9	1181	2.1	33.79	22.0					
		92.3	1060	2.3	30.35	22.0					
		98.7	991	2.5	28.36	22.0					
		109.5	893	2.8	25.57	22.0					
		118.3	827	3.0	23.66	22.0					
		120.8	857	0.8	7.45	5.0	A/F 601 160L6B / 160L6D	125	136		
		146.3	707	1.0	6.15	5.0					
		173.1	598	1.1	5.20	5.0					
		187.1	553	1.2	4.81	5.0					
		210.3	492	1.3	4.28	4.9					
		246.6	420	1.5	3.65	4.8					
		278.6	371	1.7	3.23	4.6					
		368.9	281	2.1	2.44	4.2					
		450.0	230	2.1	2.00	4.1					
		652.2	159	3.0	1.38	3.6					
	708.7	146	2.9	1.27	3.5						
	168.7	610	1.1	8.30	5.0	A/F 601 160M4C				125	136
	187.9	548	1.2	7.45	5.0						
	227.6	452	1.4	6.15	5.0						
	269.2	382	1.6	5.20	5.0						
	291.1	354	1.8	4.81	5.0						
	327.1	315	1.9	4.28	4.9						
	383.6	268	2.2	3.65	4.8						
	433.4	238	2.5	3.23	4.6						
	337.3	300	1.6	8.30	5.0	A/F 601 160M2B / 160M2C	125	136			
	375.8	270	1.8	7.45	5.0						
	455.3	223	2.2	6.15	5.0						
	538.5	188	2.5	5.20	5.0						
	582.1	174	2.7	4.81	5.0						
	654.2	155	3.0	4.28	4.9						
	45.8	2226	0.8	19.66	13.5	A/F 502 160L6B / 160L6D	133	134			
	53.4	1909	0.8	16.86	13.4						
	59.5	1713	0.9	15.13	13.3						
	65.6	1553	0.9	13.71	13.2						
	80.4	1268	0.9	11.20	12.9						
	99.9	1020	0.9	9.01	12.4						
	110.3	924	0.9	8.16	12.2						
	119.2	855	1.0	7.55	12.0						
	148.3	687	1.1	6.07	11.5						
	163.6	623	1.2	5.50	11.3						

P₁ [kW]	n₂ [Min ⁻¹]	M₂ [Nm]	f_B	i_{ges}	FR (a) [kN]	Tip / Type / Typ / Tipo / Type / Tipo IE2 / IE3	kg ~	mm			
11.0	51.9	1943	0.8	26.98	-	A/F 502 160M4C	133	134			
	60.5	1667	1.0	23.14	13.5						
	64.5	1562	1.0	21.69	13.5						
	71.2	1416	1.1	19.66	13.5						
	74.4	1355	1.1	18.81	13.5						
	83.0	1214	1.2	16.86	13.4						
	92.5	1090	1.4	15.13	13.3						
	102.1	988	1.4	13.71	13.2						
	125.0	807	1.4	11.20	12.9						
	155.4	649	1.4	9.01	12.4						
	171.6	588	1.4	8.16	12.2						
	185.4	544	1.5	7.55	12.0						
	230.6	437	1.6	6.07	11.5						
	254.5	396	1.8	5.50	11.3						
	103.8	943	1.3	26.98	13.5				A/F 502 160M2B / 160M2C	133	134
	121.0	808	1.5	23.14	13.5						
	129.1	758	1.6	21.69	13.5						
	142.4	687	1.8	19.66	13.5						
	148.9	657	1.7	18.81	13.5						
	166.1	589	1.9	16.86	13.4						
	185.1	529	2.2	15.13	13.3						
	204.2	479	2.2	13.71	13.2						
	250.0	391	2.1	11.20	12.9						
	310.8	315	2.2	9.01	12.4						
	343.1	285	2.1	8.16	12.2						
	370.9	264	2.3	7.55	12.0						
	461.3	212	2.5	6.07	11.5						
	509.1	192	2.8	5.50	11.3						
15.0	12.6	10861	0.8	71.40	55.0	A/F 903 180L6A / 180L6B	321	144			
	14.3	9586	0.9	63.02	55.0						
	15.2	9014	0.9	59.26	55.0						
	16.8	8162	1.0	53.66	55.0						
	18.6	7377	1.1	48.50	54.9						
	13.4	10042	0.8	104.41	55.0	A/F 903 160L4B	280	144			
	14.6	9246	0.9	96.13	55.0						
	16.2	8313	1.0	86.43	55.0						
	17.7	7611	1.1	79.13	55.0						
	19.6	6867	1.2	71.40	55.0						
	22.2	6061	1.3	63.02	55.0						
	23.6	5700	1.4	59.26	55.0						
	26.1	5161	1.6	53.66	55.0						
	28.9	4665	1.7	48.50	54.9						
	18.2	7083	0.9	154.07	55.0	A/F 903 160M2C / 160M2D	280	144			
	20.1	6409	0.9	139.41	55.0						
	21.8	5901	1.0	128.36	55.0						
	24.2	5325	1.1	115.83	55.0						
	26.8	4800	1.3	104.41	55.0						
	29.1	4420	1.4	96.13	55.0						
	32.4	3974	1.5	86.43	55.0						
	35.4	3638	1.7	79.13	55.0						
	39.2	3283	1.9	71.40	52.9						
	44.4	2897	2.1	63.02	55.0						
	47.2	2724	2.2	59.26	55.0						
	52.2	2467	2.5	53.66	55.0						
	57.7	2230	2.7	48.50	54.9						
	21.2	6559	1.3	42.47	53.6	A/F 902 180L6A / 180L6B	321	144			
	23.5	5919	1.4	38.33	52.6						
	28.3	4912	1.7	31.81	50.7						
	34.1	4074	2.1	26.38	48.7						
	37.8	3675	2.3	23.80	47.6						
	45.6	3050	2.8	19.75	44.2						
	33.0	4172	1.9	42.47	53.6	A/F 902 160L4B	280	144			
	36.5	3765	2.1	38.33	52.6						
	44.0	3125	2.6	31.81	50.7						
65.9	2023	3.0	42.47	53.6	A/F 902 160M2C / 160M2D	280	144				
19.7	6947	0.8	45.67	30.0	A/F 703 180L6A / 180L6B	230	142				



P ₁ [kW]	n ₂ [Min ⁻¹]	M ₂ [Nm]	f _B	i _{ges}	FR (a) [kN]	Tip / Type / Typ / Tipo / Type / Tipo IE2 / IE3	Kg ~	mm		
15.0	20.8	6474	0.8	67.31	30.0	A/F 703 160L4B	189	142		
	25.1	5362	0.9	55.75	30.0					
	30.7	4393	1.1	45.67	30.0					
	25.8	4986	0.8	108.46	30.0	A/F 703 160M2C / 160M2D	189	142		
	27.9	4615	0.8	100.38	30.0					
	31.1	4135	0.9	89.95	30.0					
	33.6	3832	1.0	83.35	30.0					
	38.0	3388	1.1	73.70	30.0					
	41.6	3095	1.2	67.31	30.0					
	50.2	2563	1.5	55.75	30.0					
	61.3	2100	1.8	45.67	30.0					
	20.1	6898	0.8	44.67	30.0	A/F 702 180L6A / 180L6B	230	142		
	24.6	5652	0.9	36.60	30.0					
	26.9	5163	1.0	33.43	30.0					
	29.7	4675	1.1	30.27	30.0					
	32.3	4304	1.2	27.87	30.0					
	36.3	3830	1.4	24.80	30.0					
	39.4	3527	1.5	22.84	30.0					
	43.1	3221	1.6	20.86	30.0					
	45.9	3027	1.7	19.60	30.0					
	52.4	2653	1.9	17.18	30.0					
	63.9	2174	2.2	14.08	29.8					
	70.0	1986	2.3	12.86	29.2					
	85.5	1626	2.6	10.53	27.8					
	104.3	1333	3.0	8.63	25.8					
	31.3	4388	1.1	44.67	30.0	A/F 702 160L4B	189	142		
	38.3	3595	1.4	36.60	30.0					
	41.9	3284	1.5	33.43	30.0					
	46.3	2973	1.7	30.27	30.0					
	50.2	2738	1.8	27.87	30.0					
	56.5	2436	2.1	24.80	30.0					
	61.3	2244	2.2	22.84	30.0					
	67.1	2049	2.4	20.86	30.0					
	71.4	1925	2.6	19.60	30.0					
	81.5	1688	2.8	17.18	30.0					
	62.7	2128	1.8	44.67	30.0	A/F 702 160M2C / 160M2D	189	142		
	76.5	1744	2.2	36.60	30.0					
	83.8	1593	2.4	33.43	30.0					
	92.5	1442	2.6	30.27	30.0					
	100.5	1328	2.9	27.87	30.0					
	115.4	1223	0.9	7.80	6.0	A/F 701 180L6A / 180L6B	177	140		
	142.2	992	1.0	6.33	6.0					
170.1	829	1.1	5.29	6.0						
184.8	764	1.2	4.87	6.0						
215.3	655	1.4	4.18	6.0						
247.9	569	1.6	3.63	6.0						
282.1	500	1.7	3.19	5.9						
300.0	470	1.8	3.00	5.8						
357.1	395	2.1	2.52	5.6						
443.3	318	2.5	2.03	5.3						
489.1	288	2.5	1.84	5.1						
179.5	782	1.3	7.80	6.0	A/F 701 160L4B				136	140
221.2	635	1.4	6.33	6.0						
264.7	530	1.7	5.29	6.0						
287.5	488	1.8	4.87	6.0						
334.9	419	2.0	4.18	6.0						
385.7	364	2.3	3.63	6.0						
438.9	320	2.6	3.19	5.9						
466.7	301	2.7	3.00	5.8						
359.0	385	2.0	7.80	6.0	A/F 701 160M2C / 160M2D	136	140			
442.3	313	2.2	6.33	6.0						
529.3	261	2.6	5.29	6.0						
574.9	240	2.8	4.87	6.0						
40.1	3212	0.8	69.87	22.0	A/F 603 160M2C / 160M2D	160	138			
50.2	2563	1.0	55.75	22.0						

P ₁ [kW]	n ₂ [Min ⁻¹]	M ₂ [Nm]	f _B	i _{ges}	FR (a) [kN]	Tip / Type / Typ / Tipo / Type / Tipo IE2 / IE3	 Kg ~	 mm			
15.0	31.7	4380	0.8	28.36	19.6	A/F 602 180L6A / 180L6B	201	138			
	35.2	3949	0.9	25.57	19.7						
	38.0	3654	0.9	23.66	19.7						
	42.5	3269	1.0	21.17	19.6						
	45.9	3025	1.1	19.59	19.5						
	51.1	2718	1.2	17.60	19.3						
	56.7	2451	1.4	15.87	19.1						
	68.5	2029	1.6	13.14	18.6						
	82.5	1685	1.9	10.91	18.0						
	91.6	1518	1.9	9.83	17.7						
	110.6	1257	2.1	8.14	17.0						
	130.1	1069	2.3	6.92	16.5						
	144.2	964	2.2	6.24	16.1						
	174.4	797	2.4	5.16	15.4						
	34.3	4009	0.8	40.81	22.0	A/F 602 160L4B	160	138			
	41.4	3319	1.0	33.79	19.4						
	46.1	2981	1.1	30.35	19.6						
	49.4	2786	1.2	28.36	19.6						
	54.8	2512	1.3	25.57	19.7						
	59.2	2324	1.4	23.66	19.7						
	66.1	2079	1.5	21.17	19.6						
	71.5	1924	1.7	19.59	19.5						
	79.5	1729	1.9	17.60	19.3						
	88.2	1559	2.1	15.87	19.1						
	106.5	1291	2.4	13.14	18.6						
	128.3	1072	2.8	10.91	18.0						
	142.4	966	2.9	9.83	17.7						
	61.9	2157	1.2	45.27	22.0	A/F 602 160M2C / 160M2D	160	138			
	68.6	1944	1.3	40.81	22.0						
	82.9	1610	1.5	33.79	19.4						
	92.3	1446	1.7	30.35	19.6						
	98.7	1351	1.9	28.36	19.6						
	109.5	1218	2.1	25.57	19.7						
	118.3	1127	2.2	23.66	19.7						
	132.3	1009	2.4	21.17	19.6						
	142.9	933	2.6	19.59	19.5						
	159.1	839	2.9	17.60	19.3						
	173.1	815	0.8	5.20	4.8	A/F 601 180L6A / 180L6B	166	136			
	187.1	754	0.9	4.81	4.8						
	210.3	671	1.0	4.28	4.6						
	246.6	572	1.1	3.65	4.5						
	278.6	506	1.2	3.23	4.4						
	368.9	383	1.5	2.44	4.2						
	450.0	314	1.5	2.00	4.0						
	652.2	216	2.2	1.38	3.6						
	708.7	199	2.1	1.27	3.5						
	168.7	832	0.8	8.30	5.0				A/F 601 160L4B	125	136
	187.9	747	0.9	7.45	5.0						
	227.6	617	1.0	6.15	4.9						
	269.2	521	1.2	5.20	4.8						
	291.1	482	1.3	4.81	4.8						
	327.1	429	1.4	4.28	4.6						
	383.6	366	1.6	3.65	4.5						
	433.4	324	1.9	3.23	4.4						
	573.8	245	2.2	2.44	4.2						
	700.0	201	2.2	2.00	4.0						
	337.3	410	1.2	8.30	5.0	A/F 601 160M2C / 160M2D	125	136			
	375.8	368	1.3	7.45	5.0						
	455.3	304	1.6	6.15	4.9						
	538.5	257	1.8	5.20	4.8						
	582.1	237	2.0	4.81	4.8						
	654.2	211	2.2	4.28	4.6						
	767.1	180	2.5	3.65	4.5						
	866.9	159	2.9	3.23	4.4						



P ₁ [kW]	n ₂ [Min ⁻¹]	M ₂ [Nm]	f _B	i _{ges}	FR (a) [kN]	Tip / Type / Typ / Tipo / Type / Tipo IE2 / IE3	 Kg ~	 mm			
15.0	64.5	2131	0.8	21.69	13.5	A/F 502 160L4B	133	134			
	71.2	1931	0.8	19.66	13.5						
	74.4	1848	0.8	18.81	13.5						
	83.0	1656	0.9	16.86	11.4						
	92.5	1486	1.0	15.13	11.6						
	102.1	1347	1.0	13.71	11.6						
	125.0	1100	1.0	11.20	11.6						
	155.4	885	1.0	9.01	11.4						
	171.6	802	1.0	8.16	11.3						
	185.4	742	1.1	7.55	11.2						
	230.6	596	1.2	6.07	10.8						
	254.5	540	1.3	5.50	10.6						
	103.8	1285	0.9	26.98	13.5				A/F 502 160M2C / 160M2D	133	134
	121.0	1102	1.1	23.14	13.5						
	129.1	1033	1.2	21.69	13.5						
	142.4	937	1.3	19.66	13.5						
	148.9	896	1.3	18.81	13.5						
	166.1	803	1.4	16.86	11.4						
	185.1	721	1.6	15.13	11.6						
	204.2	653	1.6	13.71	11.6						
	250.0	534	1.6	11.20	11.6						
	310.8	429	1.6	9.01	11.4						
	343.1	389	1.6	8.16	11.3						
	370.9	360	1.7	7.55	11.2						
	461.3	289	1.8	6.07	10.8						
	509.1	262	2.0	5.50	10.6						
	18.5	16.8	10067	0.8	53.66	52.2	A/F 903 200L6B / 200L6C	394	144		
		18.6	9099	0.9	48.50	51.7					
16.2		10253	0.8	86.43	55.0	A/F 903 180M4A / 180M4B	321	144			
17.7		9387	0.9	79.13	55.0						
19.6		8470	0.9	71.40	52.9						
22.2		7476	1.1	63.02	52.7						
23.6		7030	1.1	59.26	52.6						
26.1		6365	1.3	53.66	52.2						
28.9		5753	1.4	48.50	51.7						
20.1		7905	0.8	139.41	55.0				A/F 903 160M2D / 160L2C	280	144
21.8		7278	0.8	128.36	55.0						
24.2		6568	0.9	115.83	55.0						
26.8		5920	1.0	104.41	55.0						
29.1		5451	1.1	96.13	55.0						
32.4		4901	1.2	86.43	55.0						
35.4		4487	1.4	79.13	55.0						
39.2		4049	1.5	71.40	52.9						
44.4		3573	1.7	63.02	52.7						
47.2		3360	1.8	59.26	52.6						
52.2		3043	2.0	53.66	52.2						
57.7		2750	2.2	48.50	51.7						
21.2		8089	1.0	42.47	50.6	A/F 902 200L6B / 200L6C	394	144			
23.5		7300	1.2	38.33	49.9						
28.3		6059	1.4	31.81	48.5						
34.1		5024	1.7	26.38	46.9						
37.8		4533	1.9	23.80	46.0						
45.6		3762	2.2	19.75	44.2						
52.4		3272	2.5	17.18	42.8						
58.1	2952	2.8	15.50	40.7							
33.0	5145	1.6	42.47	50.6	A/F 902 180M4A / 180M4B	321	144				
36.5	4644	1.7	38.33	49.9							
44.0	3854	2.1	31.81	48.5							
53.1	3196	2.5	26.38	46.9							
58.8	2883	2.8	23.80	46.0							
65.9	2495	2.4	42.47	50.6	A/F 902 160M2D / 160L2C	280	144				
73.0	2252	2.7	38.33	49.9							
30.7	5418	0.9	45.67	30.0	A/F 703 180M4A / 180M4B	230	142				
25.1	6613	0.8	55.75	30.0							

P₁ [kW]	n₂ [Min ⁻¹]	M₂ [Nm]	f_B	i_{ges}	FR (a) [kN]	Tip / Type / Typ / Tipo / Type / Tipo IE2 / IE3	Kg ~	mm
18.5	33.6	4726	0.8	83.35	30.0	A/F 703 160M2D / 160L2C	189	142
	38.0	4179	0.9	73.70	30.0			
	41.6	3817	1.0	67.31	30.0			
	50.2	3161	1.2	55.75	30.0			
	61.3	2590	1.5	45.67	30.0			
	32.3	5308	1.0	27.87	30.0	A/F 702 200L6B / 200L6C	288	142
	39.4	4350	1.2	22.84	30.0			
	43.1	3973	1.3	20.86	30.0			
	45.9	3733	1.4	19.60	30.0			
	85.5	2006	2.1	10.53	27.0			
	104.3	1644	2.4	8.63	25.8			
	114.2	1501	2.6	7.88	25.2			
	125.0	1371	2.8	7.20	24.1			
	152.5	1124	3.0	5.90	23.0			
	31.3	5412	0.9	44.67	30.0	A/F 702 180M4A / 180M4B	230	142
	38.3	4434	1.1	36.60	30.0			
	41.9	4050	1.2	33.43	30.0			
	46.3	3667	1.4	30.27	30.0			
	50.2	3376	1.5	27.87	30.0			
56.5	3004	1.7	24.80	30.0				
61.3	2767	1.8	22.84	30.0				
67.1	2527	2.0	20.86	30.0				
71.4	2375	2.1	19.60	30.0				
81.5	2081	2.3	17.18	30.0				
99.4	1706	2.7	14.08	28.8				
108.9	1558	2.8	12.86	28.3				
62.7	2625	1.4	44.67	30.0	A/F 702 160M2D / 160L2C	189	142	
76.5	2151	1.8	36.60	30.0				
83.8	1964	1.9	33.43	30.0				
92.5	1779	2.1	30.27	30.0				
100.5	1638	2.3	27.87	30.0				
112.9	1457	2.6	24.80	30.0				
122.6	1342	2.8	22.84	30.0				
184.8	942	1.0	4.87	6.0	A/F 701 200L6B / 200L6C	235	140	
215.3	808	1.1	4.18	6.0				
247.9	702	1.3	3.63	5.9				
443.3	393	2.0	2.03	5.2				
489.1	356	2.1	1.84	5.0				
625.0	278	2.6	1.44	4.6				
714.3	244	2.8	1.26	4.5				
179.5	965	1.0	7.80	6.0				A/F 701 180M4A / 180M4B
221.2	783	1.1	6.33	6.0				
264.7	654	1.3	5.29	6.0				
287.5	602	1.4	4.87	6.0				
334.9	517	1.6	4.18	6.0				
385.7	449	1.9	3.63	5.9				
438.9	395	2.1	3.19	5.8				
466.7	371	2.2	3.00	5.7				
555.6	312	2.6	2.52	5.4				
689.7	251	3.0	2.03	5.2				
359.0	475	1.6	7.80	6.0	A/F 701 160M2D / 160L2C	136	140	
442.3	385	1.8	6.33	6.0				
529.3	322	2.1	5.29	6.0				
574.9	297	2.2	4.87	6.0				
669.9	255	2.5	4.18	6.0				
771.3	221	2.9	3.63	5.9				
50.2	3161	0.8	55.75	22.0	A/F 603 160M2D / 160L2C	160	138	

P₁ [kW]	n₂ [Min ⁻¹]	M₂ [Nm]	f_B	i_{ges}	FR (a) [kN]	Tip / Type / Typ / Tipo / Type / Tipo IE2 / IE3	kg ~	mm			
18.5	49.4	3436	1.0	28.36	17.1	A/F 602 180M4A / 180M4B	201	138			
	54.8	3098	1.1	25.57	17.4						
	59.2	2866	1.2	23.66	17.6						
	66.1	2565	1.2	21.17	17.7						
	71.5	2373	1.3	19.59	17.7						
	79.5	2132	1.5	17.60	17.7						
	88.2	1923	1.7	15.87	17.7						
	106.5	1592	1.9	13.14	17.4						
	128.3	1322	2.3	10.91	17.1						
	142.4	1191	2.4	9.83	16.8						
	172.0	986	2.5	8.14	16.3						
	202.3	838	2.7	6.92	15.8						
	224.4	756	2.6	6.24	15.5						
	271.3	625	2.9	5.16	14.9						
	61.9	2660	0.9	45.27	22.0				A/F 602 160M2D / 160L2C	160	138
	68.6	2398	1.0	40.81	22.0						
	82.9	1985	1.2	33.79	19.4						
	92.3	1783	1.4	30.35	19.6						
	98.7	1666	1.5	28.36	17.1						
	109.5	1502	1.7	25.57	17.4						
	118.3	1390	1.8	23.66	17.6						
	132.3	1244	2.0	21.17	17.7						
	142.9	1151	2.1	19.59	17.7						
	159.1	1034	2.4	17.60	17.7						
	176.4	932	2.6	15.87	17.7						
	269.2	643	1.0	5.20	4.5	A/F 601 180M4A / 180M4B	166	136			
	291.1	595	1.0	4.81	4.5						
	327.1	529	1.2	4.28	4.4						
	383.6	451	1.3	3.65	4.3						
	433.4	399	1.5	3.23	4.2						
	573.8	302	1.8	2.44	4.0						
	700.0	247	1.8	2.00	3.9						
	1014.5	171	2.6	1.38	3.5						
	1102.4	157	2.5	1.27	3.5						
	337.3	505	1.0	8.30	4.5	A/F 601 160M2D / 160L2C	125	136			
	375.8	454	1.1	7.45	4.5						
	455.3	374	1.3	6.15	4.5						
	538.5	317	1.5	5.20	4.5						
	582.1	293	1.6	4.81	4.5						
	654.2	261	1.8	4.28	4.4						
	767.1	222	2.1	3.65	4.3						
	866.9	197	2.3	3.23	4.2						
	1147.5	149	2.8	2.44	4.0						
	1400.0	122	2.8	2.00	3.9						
	103.8	1585	0.8	26.98	13.5	A/F 502 160M2D / 160L2C	133	134			
	121.0	1360	0.9	23.14	13.5						
	129.1	1274	1.0	21.69	13.5						
	142.4	1155	1.1	19.66	13.5						
148.9	1105	1.0	18.81	13.5							
166.1	991	1.2	16.86	11.4							
185.1	889	1.3	15.13	11.6							
204.2	806	1.3	13.71	11.6							
250.0	658	1.3	11.20	11.6							
310.8	529	1.3	9.01	11.4							
343.1	479	1.3	8.16	11.3							
370.9	444	1.4	7.55	11.2							
461.3	357	1.5	6.07	10.8							
509.1	323	1.6	5.50	10.6							
22.0	18.6	10820	0.8	48.50	48.4				A/F 903 200L6C / 200L6D	394	144
	19.6	10072	0.8	71.40	52.9	A/F 903 180M4B / 180L4B	321	144			
	22.2	8890	0.9	63.02	48.5						
	23.6	8360	1.0	59.26	48.6						
	26.1	7570	1.1	53.66	48.6						
28.9	6842	1.2	48.50	48.4							

P ₁ [kW]	n ₂ [Min ⁻¹]	M ₂ [Nm]	f _B	i _{ges}	FR (a) [kN]	Tip / Type / Typ / Tipo / Type / Tipo IE2 / IE3	 Kg ~	 mm			
22.0	24.2	7810	0.8	115.83	55.0	A/F 903 180M2A	321	144			
	26.8	7040	0.9	104.41	55.0						
	29.1	6482	0.9	96.13	55.0						
	32.4	5828	1.0	86.43	55.0						
	35.4	5336	1.1	79.13	55.0						
	39.2	4814	1.3	71.40	52.9						
	44.4	4249	1.4	63.02	48.5						
	47.2	3996	1.5	59.26	48.6						
	52.2	3618	1.7	53.66	48.6						
	57.7	3270	1.9	48.50	48.4						
	21.2	9619	0.9	42.47	47.7				A/F 902 200L6C / 200L6D	394	144
	23.5	8682	1.0	38.33	47.3						
	28.3	7205	1.2	31.81	46.3						
	34.1	5975	1.4	26.38	45.1						
	37.8	5391	1.6	23.80	44.3						
	45.6	4473	1.9	19.75	42.8						
	52.4	3891	2.1	17.18	41.6						
	58.1	3511	2.3	15.50	40.7						
	70.0	2913	2.6	12.86	39.1						
	33.0	6119	1.3	42.47	47.7	A/F 902 180M4B / 180L4B	321	144			
	36.5	5522	1.4	38.33	47.3						
	44.0	4583	1.7	31.81	46.3						
	53.1	3801	2.1	26.38	45.1						
	58.8	3429	2.3	23.80	44.3						
	70.9	2845	2.8	19.75	42.8						
	65.9	2968	2.0	42.47	47.7	A/F 902 180M2A	321	144			
	73.0	2678	2.3	38.33	47.3						
	88.0	2223	2.7	31.81	46.3						
	30.7	6443	0.8	45.67	30.0	A/F 703 180M4B / 180L4B	230	142			
	38.0	4970	0.8	73.70	30.0	A/F 703 180M2A	230	142			
	41.6	4539	0.8	67.31	30.0						
	50.2	3759	1.0	55.75	30.0						
	61.3	3080	1.2	45.67	30.0						
	32.3	6312	0.8	27.87	30.0	A/F 702 200L6C / 200L6D	288	142			
	39.4	5173	1.0	22.84	29.7						
	43.1	4725	1.1	20.86	29.4						
	45.9	4439	1.2	19.60	29.2						
	85.5	2385	1.8	10.53	26.3						
	104.3	1955	2.0	8.63	25.2						
	114.2	1785	2.2	7.88	24.7						
	125.0	1631	2.3	7.20	24.1						
	152.5	1336	2.5	5.90	23.0						
	167.3	1219	2.6	5.38	22.4						
	31.3	6436	0.8	44.67	30.0				A/F 702 180M4B / 180L4B	230	142
	38.3	5273	0.9	36.60	30.0						
	41.9	4816	1.0	33.43	30.0						
	46.3	4361	1.1	30.27	30.0						
	50.2	4015	1.2	27.87	30.0						
56.5	3573	1.4	24.80	29.9							
61.3	3291	1.5	22.84	29.7							
67.1	3005	1.7	20.86	29.4							
71.4	2824	1.8	19.60	29.2							
81.5	2475	1.9	17.18	28.7							
99.4	2028	2.3	14.08	27.8							
108.9	1853	2.4	12.86	27.3							
133.0	1517	2.6	10.53	26.3							
62.7	3121	1.2	44.67	30.0	A/F 702 180M2A	230	142				
76.5	2557	1.5	36.60	30.0							
83.8	2336	1.6	33.43	30.0							
92.5	2115	1.8	30.27	30.0							
100.5	1947	2.0	27.87	30.0							
112.9	1733	2.2	24.80	29.9							
122.6	1596	2.4	22.84	29.7							
134.2	1458	2.6	20.86	29.4							
142.9	1370	2.8	19.60	29.2							
163.0	1200	3.0	17.18	28.7							

P ₁ [kW]	n ₂ [Min ⁻¹]	M ₂ [Nm]	f _B	i _{ges}	FR (a) [kN]	Tip / Type / Typ / Tipo / Type / Tipo IE2 / IE3	Kg ~	mm
22.0	184.8	1120	0.8	4.87	6.0	A/F 701 200L6C / 200L6D	235	140
	215.3	961	0.9	4.18	5.9			
	247.9	835	1.1	3.63	5.7			
	443.3	467	1.7	2.03	5.1			
	489.1	423	1.7	1.84	4.9			
	625.0	331	2.2	1.44	4.6			
	714.3	290	2.4	1.26	4.5			
	179.5	1147	0.9	7.80	6.0	A/F 701 180M4B / 180L4B	177	140
	221.2	931	1.0	6.33	6.0			
	264.7	778	1.1	5.29	6.0			
	287.5	716	1.2	4.87	6.0			
	334.9	615	1.4	4.18	5.9			
	385.7	534	1.6	3.63	5.7			
	438.9	469	1.7	3.19	5.6			
	466.7	441	1.8	3.00	5.5			
	555.6	371	2.2	2.52	5.3			
	689.7	299	2.5	2.03	5.1			
	760.9	271	2.6	1.84	4.9			
	359.0	565	1.3	7.80	6.0	A/F 701 180M2A	177	140
	442.3	458	1.5	6.33	6.0			
	529.3	383	1.7	5.29	6.0			
	574.9	353	1.9	4.87	6.0			
	669.9	303	2.1	4.18	5.9			
	771.3	263	2.5	3.63	5.7			
	877.7	231	2.7	3.19	5.6			
	933.3	217	2.8	3.00	5.5			
	49.4	4086	0.8	28.36	17.1	A/F 602 180M4B / 180L4B	201	138
	54.8	3684	0.9	25.57	17.4			
	59.2	3409	1.0	23.66	15.5			
	66.1	3050	1.0	21.17	15.8			
	71.5	2822	1.1	19.59	16.0			
	79.5	2536	1.3	17.60	16.2			
	88.2	2286	1.4	15.87	16.3			
	106.5	1893	1.6	13.14	16.3			
	128.3	1572	1.9	10.91	16.1			
	142.4	1416	2.0	9.83	16.0			
	172.0	1173	2.1	8.14	15.6			
	202.3	997	2.3	6.92	15.2			
	224.4	899	2.2	6.24	15.0			
	271.3	743	2.4	5.16	14.5			
	98.7	1982	1.3	28.36	17.1			
	109.5	1787	1.4	25.57	17.4			
118.3	1653	1.5	23.66	15.5				
132.3	1479	1.6	21.17	15.8				
142.9	1369	1.8	19.59	16.0				
159.1	1230	2.0	17.60	16.2				
176.4	1109	2.2	15.87	16.3				
213.1	918	2.6	13.14	16.3				
256.6	762	3.0	10.91	16.1				
269.2	765	0.8	5.20	4.5	A/F 601 180M4B / 180L4B	166	136	
291.1	707	0.9	4.81	4.5				
327.1	629	1.0	4.28	4.4				
383.6	537	1.1	3.65	4.1				
433.4	475	1.3	3.23	4.0				
573.8	359	1.5	2.44	3.9				
700.0	294	1.5	2.00	3.7				
1014.5	203	2.2	1.38	3.5				
1102.4	187	2.1	1.27	3.4				
538.5	377	1.3	5.20	4.5				A/F 601 180M2A
582.1	348	1.4	4.81	4.5				
654.2	310	1.5	4.28	4.4				
767.1	264	1.7	3.65	4.1				
866.9	234	1.9	3.23	4.0				
1147.5	177	2.4	2.44	3.9				
1400.0	145	2.4	2.00	3.7				

P ₁ [kW]	n ₂ [Min ⁻¹]	M ₂ [Nm]	f _B	i _{ges}	FR (a) [kN]	Tip / Type / Typ / Tipo / Type / Tipo IE2 / IE3	 Kg ~	 mm
30.0	26.1 28.9	10322 9330	0.8 0.9	53.66 48.50	48.6 48.4	A/F 903 200L4C / 200L4D	394	144
	32.4 52.2 57.7	7947 4934 4460	0.8 1.2 1.4	86.43 53.66 48.50	48.6 48.6 48.4	A/F 903 200L2B / 200L2C	394	144
	28.3 34.1 37.8 45.6 52.4 58.1 70.0 87.5 97.0 116.9 130.6 144.7 174.4	9825 8148 7351 6100 5306 4787 3972 3175 2866 2378 2128 1921 1594	0.9 1.0 1.1 1.4 1.6 1.7 1.9 2.4 2.4 2.3 2.5 2.7 3.0	31.81 26.38 23.80 19.75 17.18 15.50 12.86 10.28 9.28 7.70 6.89 6.22 5.16	41.3 40.9 40.5 39.7 38.9 38.3 37.0 35.4 34.6 33.1 32.3 31.5 29.3	A/F 902 225M6B / 225M6C	470	144
	33.0 36.5 44.0 53.1 58.8 70.9 81.5 90.3 108.9	8344 7530 6249 5183 4676 3880 3375 3045 2526	1.0 1.1 1.3 1.5 1.7 2.1 2.3 2.6 2.9	42.47 38.33 31.81 26.38 23.80 19.75 17.18 15.50 12.86	40.9 41.2 41.3 40.9 40.5 39.7 38.9 38.3 37.0	A/F 902 200L4C / 200L4D	394	144
	65.9 73.0 88.0 106.1 117.6	4047 3652 3031 2514 2268	1.5 1.7 2.0 2.4 2.7	42.47 38.33 31.81 26.38 23.80	40.9 41.2 41.3 40.9 40.5	A/F 902 200L2B / 200L2C	394	144
	61.3	4199	0.9	45.67	30.0	A/F 703 200L2B / 200L2C	288	142
	50.2 61.3 67.1 71.4 133.0 162.2 177.7 194.4 237.3 260.2	5475 4487 4098 3851 2069 1695 1548 1414 1159 1057	0.9 1.1 1.2 1.3 1.9 2.2 2.4 2.5 2.8 2.8	27.87 22.84 20.86 19.60 10.53 8.63 7.88 7.20 5.90 5.38	25.5 25.9 26.0 26.0 24.5 23.7 23.3 22.9 22.0 21.5	A/F 702 200L4C / 200L4D	288	142
	100.5 122.6 134.2 142.9 265.9	2656 2176 1988 1868 1003	1.4 1.7 1.9 2.0 3.0	27.87 22.84 20.86 19.60 10.53	25.5 25.9 26.0 26.0 24.5	A/F 702 200L2B / 200L2C	288	142
	287.5 334.9 385.7 689.7 760.9 972.2 1111.1	977 838 728 407 369 289 253	0.9 1.0 1.2 1.8 1.9 2.4 2.6	4.87 4.18 3.63 2.03 1.84 1.44 1.26	5.5 5.4 5.3 4.8 4.7 4.5 4.3	A/F 701 200L4C / 200L4D	235	140
	574.9 669.9 771.3 1379.3 1521.7	481 413 358 200 182	1.4 1.6 1.8 2.8 2.9	4.87 4.18 3.63 2.03 1.84	5.5 5.4 5.3 4.8 4.7	A/F 701 200L2B / 200L2C	235	140
	383.6 433.4 573.8 700.0 1014.5 1102.4	732 648 489 401 277 255	0.8 0.9 1.1 1.1 1.6 1.6	3.65 3.23 2.44 2.00 1.38 1.27	- - - - - -	A/F 601 200L4C / 200L4D	224	136

P₁ [kW]	n₂ [Min ⁻¹]	M₂ [Nm]	f_B	i_{ges}	FR (a) [kN]	Tip / Type / Typ / Tipo / Type / Tipo IE2 / IE3	Kg ~	mm			
37.0	52.2	6085	1.0	53.66	48.6	A/F 903 200L2C / 200L2D	394	144			
	57.7	5500	1.1	48.50	48.6						
	33.0	10290	0.8	42.47	40.9	A/F 902 225M4A / 225M4B	470	144			
	36.5	9287	0.9	38.33	41.2						
	44.0	7707	1.0	31.81	36.8						
	53.1	6392	1.3	26.38	37.2						
	58.8	5767	1.4	23.80	37.2						
	70.9	4785	1.7	19.75	36.9						
	81.5	4163	1.9	17.18	36.5						
	90.3	3756	2.1	15.50	36.1						
	108.9	3116	2.3	12.86	35.2						
	136.2	2491	2.9	10.28	33.9						
	150.9	2249	2.9	9.28	33.3						
	181.8	1866	2.8	7.70	32.1						
	203.2	1669	3.0	6.89	31.3						
	65.9	4991	1.2	42.47	40.9	A/F 902 200L2C / 200L2D	394	144			
	73.0	4504	1.3	38.33	41.2						
	88.0	3738	1.6	31.81	36.8						
	106.1	3100	2.0	26.38	37.2						
	117.6	2797	2.2	23.80	37.2						
	141.8	2321	2.6	19.75	36.9						
	163.0	2019	3.0	17.18	36.5						
	100.5	3275	1.2	27.87	25.5	A/F 702 200L2C / 200L2D	288	142			
	122.6	2684	1.4	22.84	25.5						
134.2	2451	1.6	20.86	25.5							
142.9	2303	1.6	19.60	25.5							
265.9	1237	2.5	10.53	25.5							
324.4	1014	2.8	8.63	25.5							
355.3	926	3.0	7.88	25.5							
574.9	593	1.1	4.87	5.5	A/F 701 200L2C / 200L2D	235	140				
669.9	509	1.3	4.18	5.4							
771.3	442	1.5	3.63	5.3							
1379.3	247	2.3	2.03	4.8							
1521.7	224	2.4	1.84	4.7							
1944.4	175	3.0	1.44	4.5							
45.0	44.0	9374	0.9	31.81	41.3	A/F 902 225M4B / 225M4C	470	144			
	53.1	7774	1.0	26.38	33.0						
	58.8	7014	1.1	23.80	33.4						
	70.9	5820	1.4	19.75	33.8						
	81.5	5063	1.6	17.18	33.8						
	90.3	4568	1.7	15.50	33.6						
	108.9	3790	1.9	12.86	33.2						
	136.2	3029	2.4	10.28	32.3						
	150.9	2735	2.4	9.28	31.8						
	181.8	2269	2.3	7.70	30.8						
	203.2	2030	2.5	6.89	30.2						
	225.1	1833	2.7	6.22	29.6						
	271.3	1521	3.0	5.16	28.5						
	65.9	6070	1.0	42.47	41.3				A/F 902 225M2B	470	144
	73.0	5478	1.1	38.33	41.3						
	88.0	4546	1.3	31.81	41.3						
	106.1	3770	1.6	26.38	33.0						
	117.6	3402	1.8	23.80	33.4						
	141.8	2823	2.2	19.75	33.8						
	163.0	2455	2.4	17.18	33.8						
	180.6	2215	2.7	15.50	33.6						
	217.7	1838	3.0	12.86	33.2						

Ölçü Tabloları

Dimension Tables

Maßtabellen

Dimensione Tabelle

Tables De Dimension

Tablas De Dimensiones

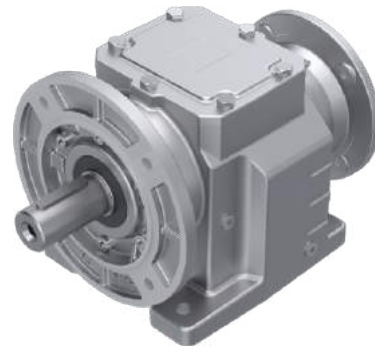
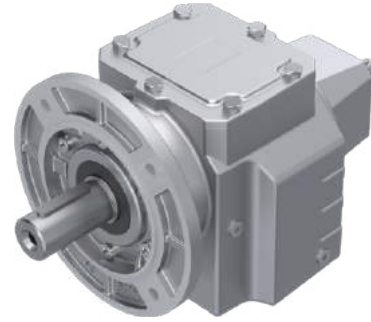
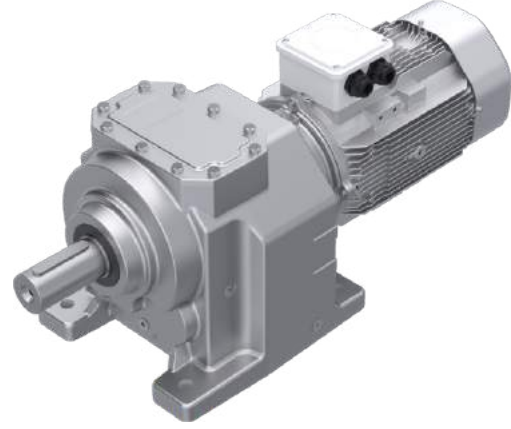

A/F

A 202

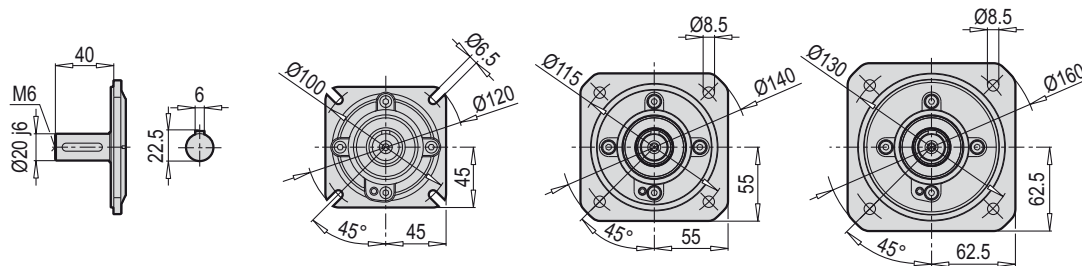
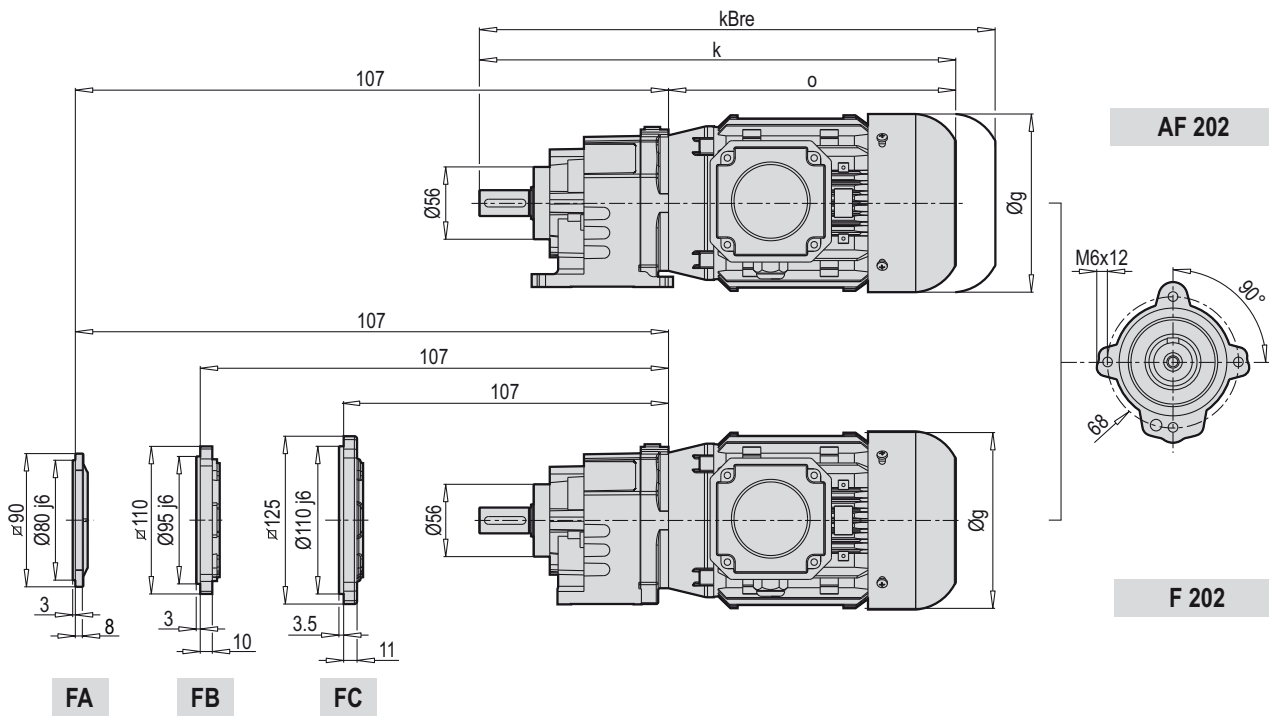
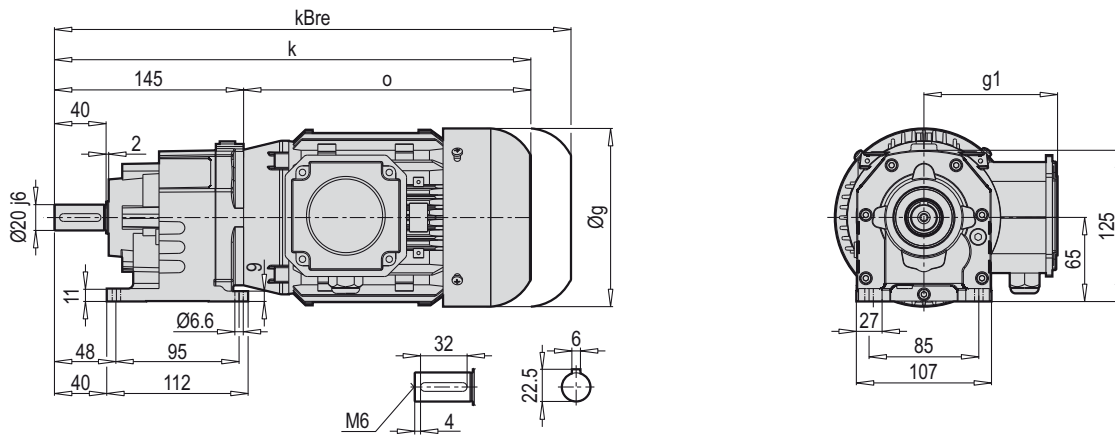

(A/F 202 - F202) FA

(F202) FB

(F202) FC

	63 M	71 M					
g	124	140					
g1	111	119					
k	342	368					
kBre	394	428					
o	197	223					

A 202 PAM B5/B14

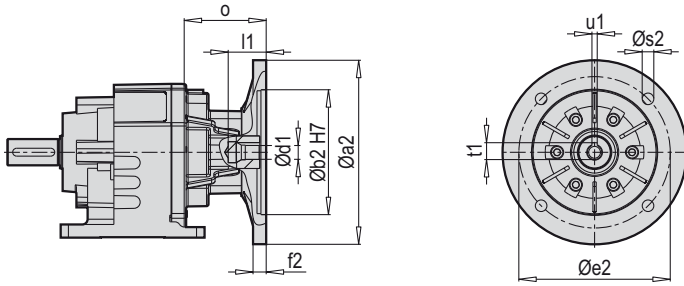

F 202 PAM B5/B14

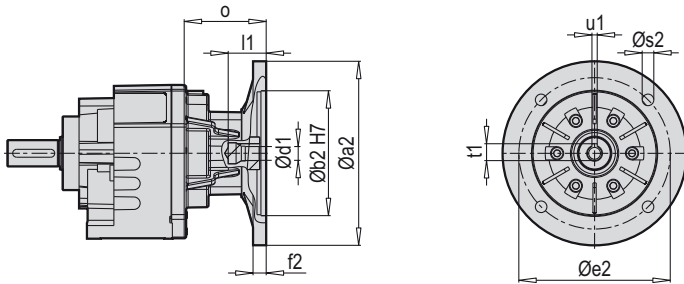

AF 202 PAM B5/B14

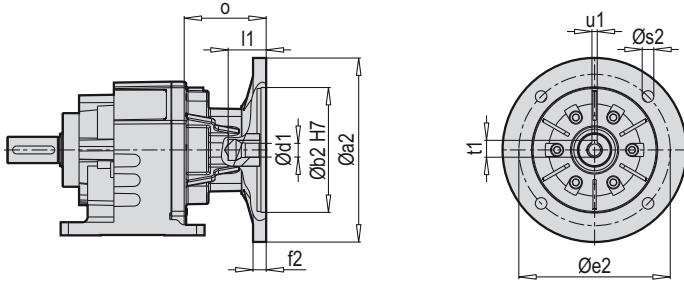

Tip / Type Typ / Tipo Type / Tipo	PAM B5	Øa2	Øb2	Øe2	f2	Øs2	Ød1	l1	t1	u1	o
A/F 202	56	120	80	100	3.5	M6	9	20	10.2	3	29.5
	63	140	95	115	3.5	M8	11	23	12.8	4	59.5

~ Kg	
PAM B5	A/F 202
56	5
63	5

Tip / Type Typ / Tipo Type / Tipo	PAM B14	Øa2	Øb2	Øe2	f2	Øs2	Ød1	l1	t1	u1	o
A/F 202	56	80	50	65	3	6	9	20	10.4	3	32.5
	63	90	60	75	2.5	6	11	23	12.8	4	59.5
	71	105	70	85	2.5	7	14	30	16.3	5	59.5

~ Kg	
PAM B14	A/F 202
56	4
63	4
71	5

A 202 G

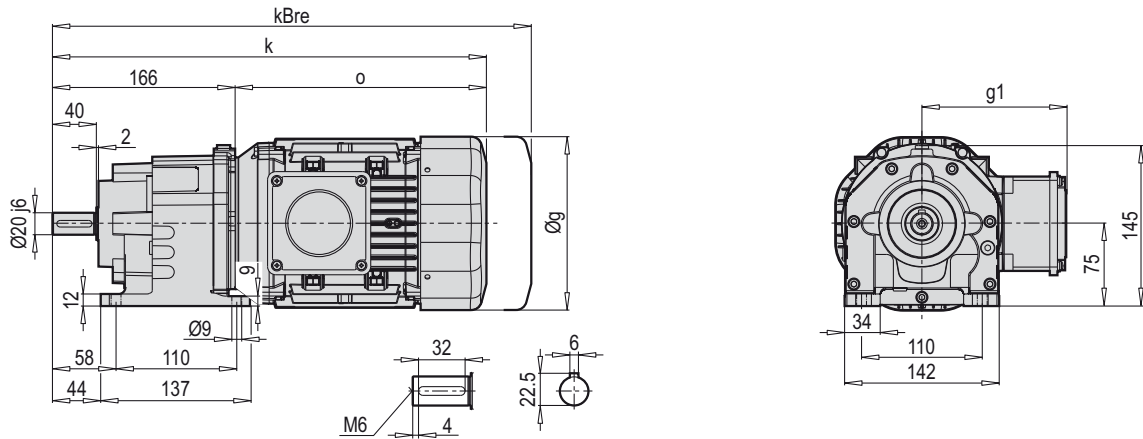

AF 202 G

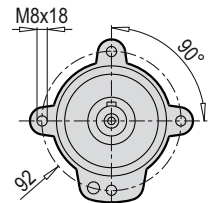
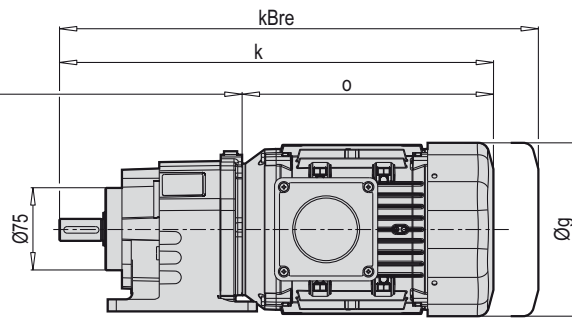

F 202 G

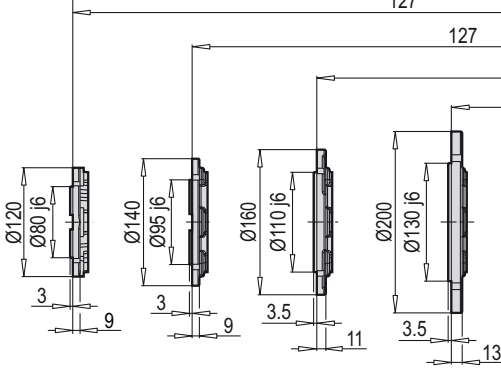

FA FB FC FD

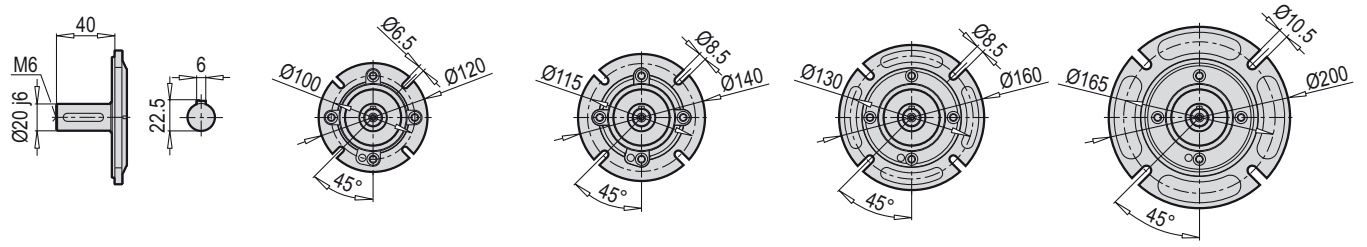

FA FB FC FD

	63 M	71 M	80 M	90 S/L				
g	124	140	172	182				
g1	111	119	130.5	130				
k	378	407	395	474				
kBre	430	467	466	542				
o	212	241	229	330				

A 202 G PAM B5/B14

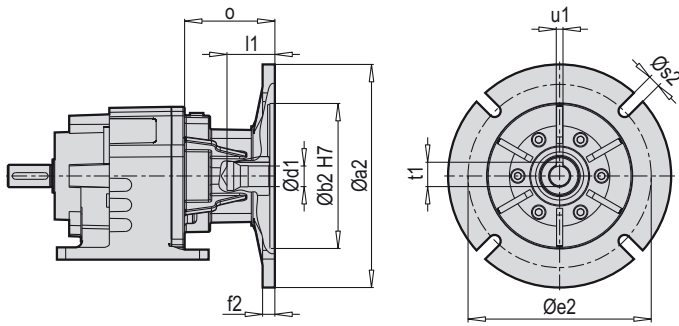

A 202 G W

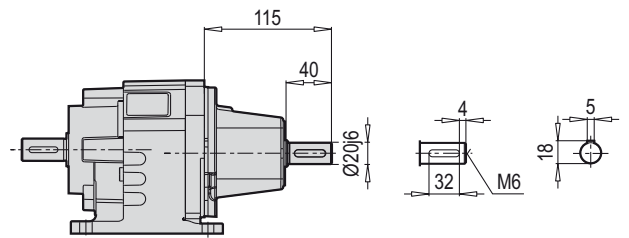

F 202 G PAM B5/B14

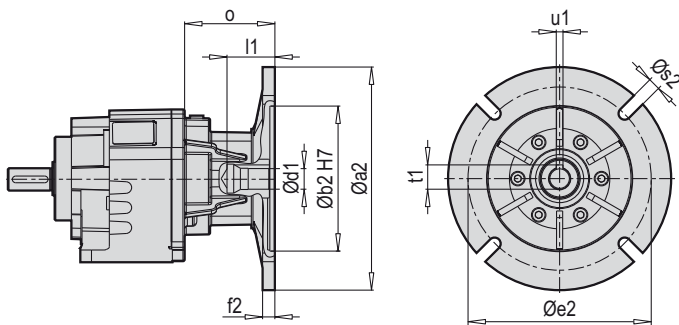

F 202 G W

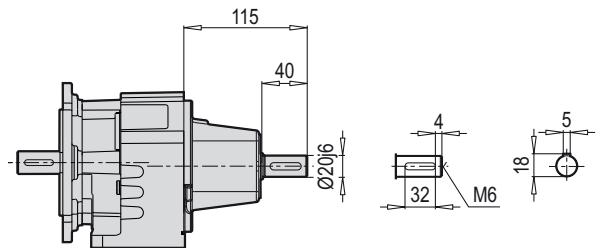

AF 202 G PAM B5/B14

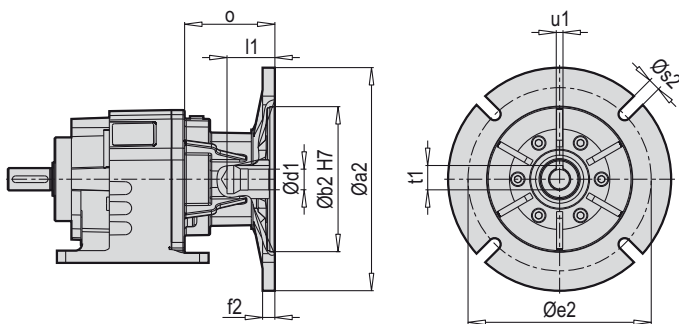

AF 202 G W

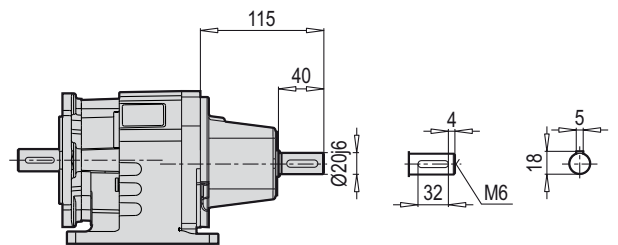

Tip / Type Typ / Tipo Type / Tipo	PAM B5	Øa2	Øb2	Øe2	f2	Øs2	Ød1	l1	t1	u1	o
A/F 202 G	56	120	80	100	3.5	M6	9	20	10.2	3	29.5
	63	140	95	115	3.5	M8	11	23	12.8	4	74.5
	71	160	110	130	4	M8	14	30	16.3	5	74.5
	80	200	130	165	4	M10	19	40	21.8	6	74.5
	90	200	130	165	4	M10	24	50	27.3	8	87.5

~ Kg	
PAM B5	A/F 202 G
56	8
63	8
71	8
80	8
90	8

Tip / Type Typ / Tipo Type / Tipo	PAM B14	Øa2	Øb2	Øe2	f2	Øs2	Ød1	l1	t1	u1	o
A/F 202 G	56	80	50	65	3	6	9	20	10.4	3	32.5
	63	90	60	75	2.5	6	11	23	12.8	4	74.5
	71	105	70	85	2.5	7	14	30	16.3	5	74.5
	80	120	80	100	3	7	19	40	21.8	6	74.5
	90	140	95	115	3	9	24	50	27.3	8	87.5

~ Kg	
PAM B14	A/F 202 G
56	6
63	6
71	7
80	8
90	8

A 252-253

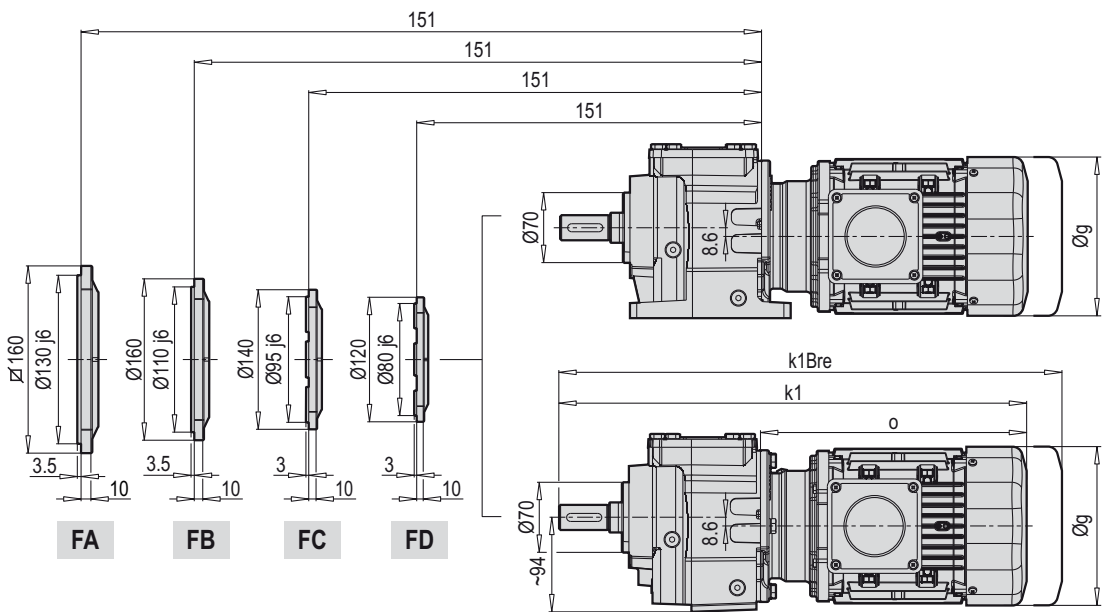
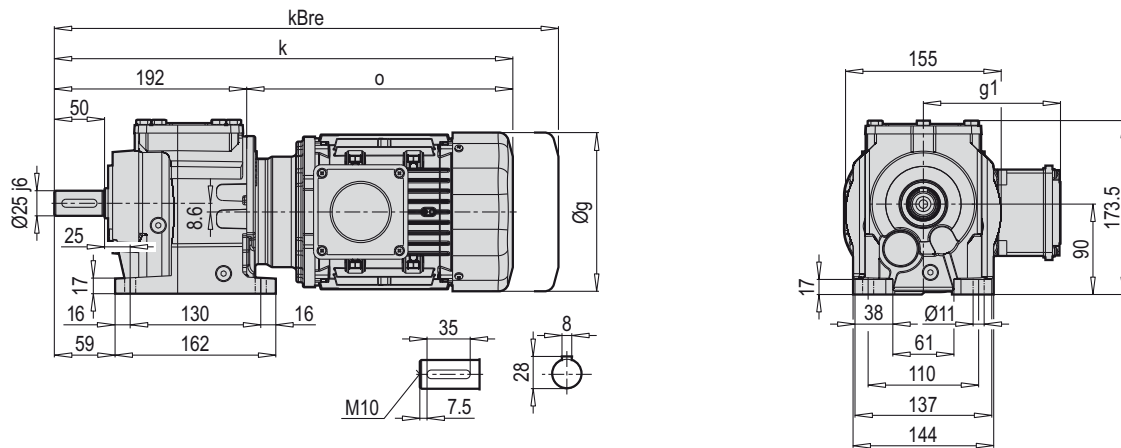

AF 252-253

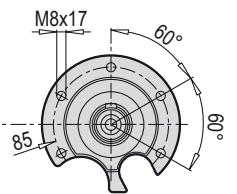

F 252-253

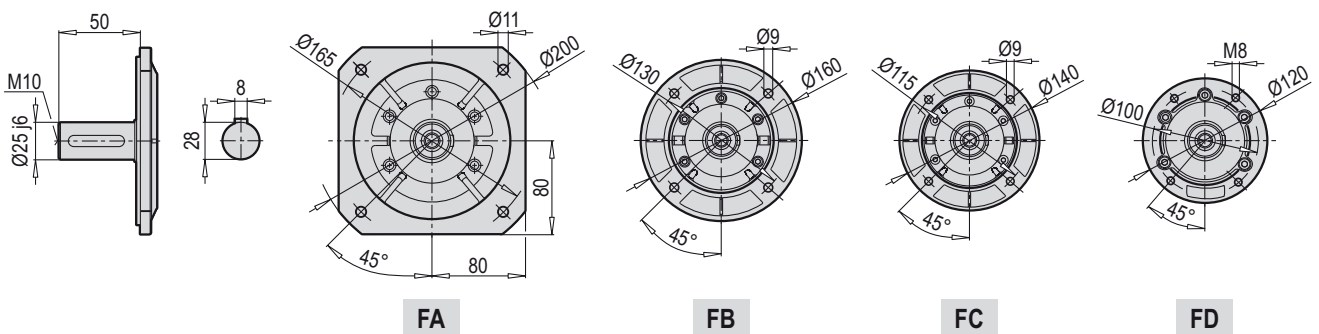

FA

FB

FC

FD

	63 M	71 M	80 M	90 S/L	100 L	112 M		
g	124	140	172	182	202	220		
g1	111	119	130.5	130	153	158.5		
k	404	433	457	540	571	575		
kBre	456	493	528	608	654	675		
o	212	241	265	348	379	383		
k1	413	442	467	550	581	585		
k1Bre	465	502	538	618	664	685		

A 252-253 PAM B5/B14

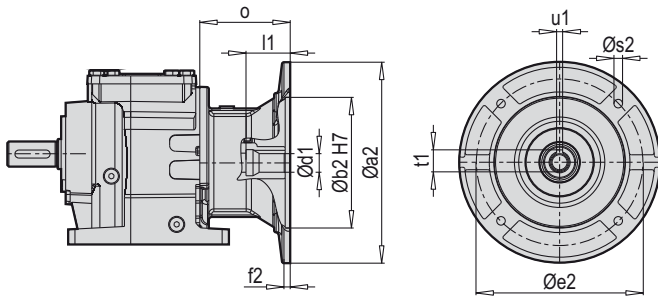

A 252-253 W

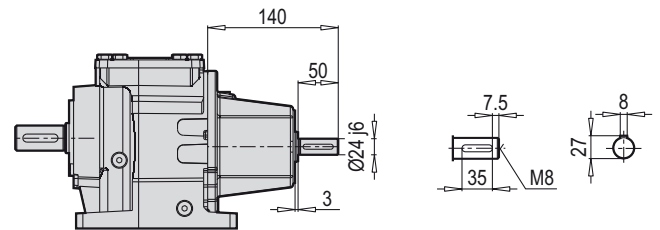

F 252-253 PAM B5/B14

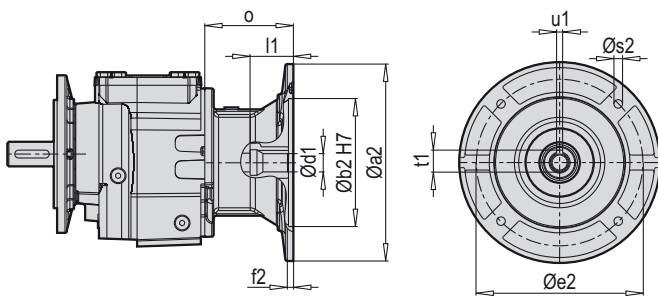

F 252-253 W

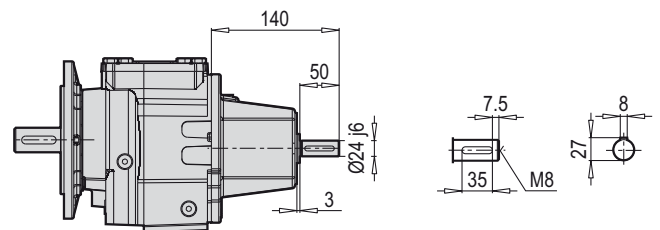

AF 252-253 PAM B5/B14

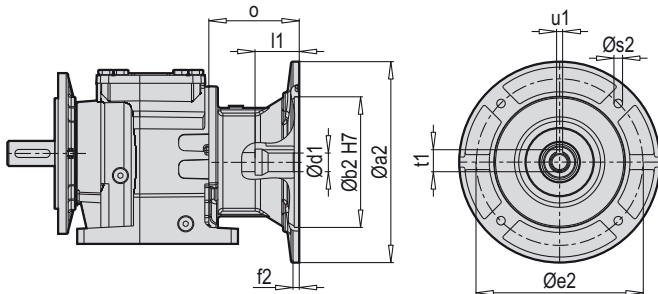

AF 252-253 W

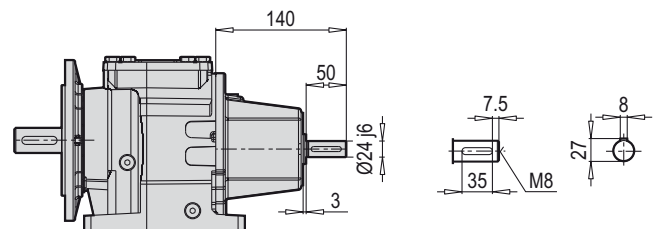

W ~ Kg	
A/F 252 - 253	14

Tip / Type Typ / Tipo Type / Tipo	PAM B5	Øa2	Øb2	Øe2	f2	Øs2	Ød1	l1	t1	u1	o
A/F 252 A/F 253	63	140	95	115	4.5	M8	11	25	12.8	4	57
	71	160	110	130	5	M8	14	32	16.3	5	69
	80	200	130	165	5	M10	19	42	21.8	6	90
	90	200	130	165	5	M10	24	52	27.3	8	90
	100	250	180	215	5.5	M12	28	62	31.3	8	105
	112	250	180	215	5.5	M12	28	62	31.3	8	105

~ Kg	
PAM B5	A/F 252 - 253
63	12
71	13
80	14
90	14
100	18
112	18

Tip / Type Typ / Tipo Type / Tipo	PAM B14	Øa2	Øb2	Øe2	f2	Øs2	Ød1	l1	t1	u1	o
A/F 252 A/F 253	63	90	60	75	2.5	6	11	25	12.8	4	57
	71	105	70	85	2.5	7	14	32	16.3	5	69
	80	120	80	100	3	7	19	42	21.8	6	90
	90	140	95	115	3	9	24	52	27.3	8	90
	100	160	110	130	3.5	9	28	62	31.3	8	105
	112	160	110	130	3.5	9	28	62	31.3	8	105

~ Kg	
PAM B14	A/F 252 - 253
63	11
71	12
80	13
90	13
100	14
112	14

A 301

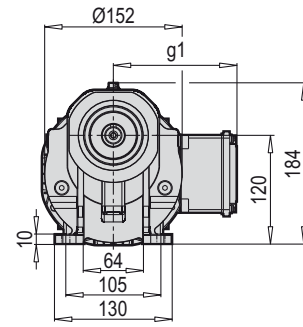
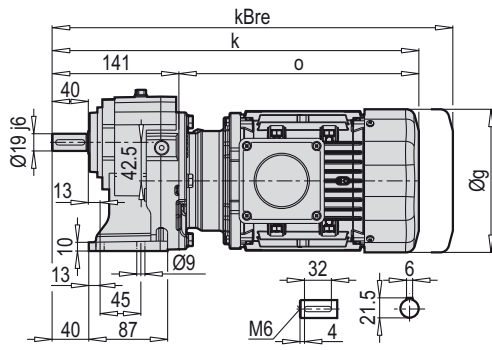

AF-M 301

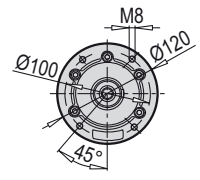
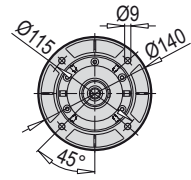
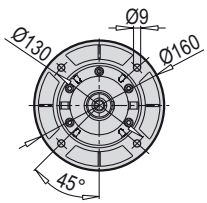
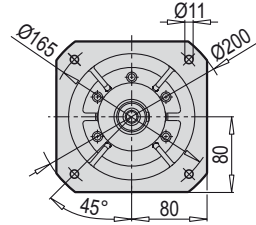
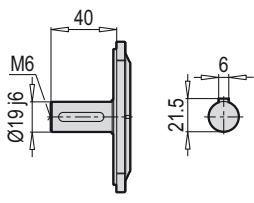
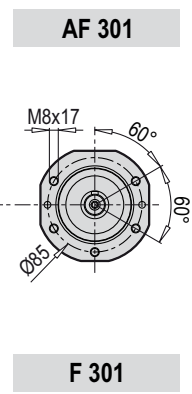
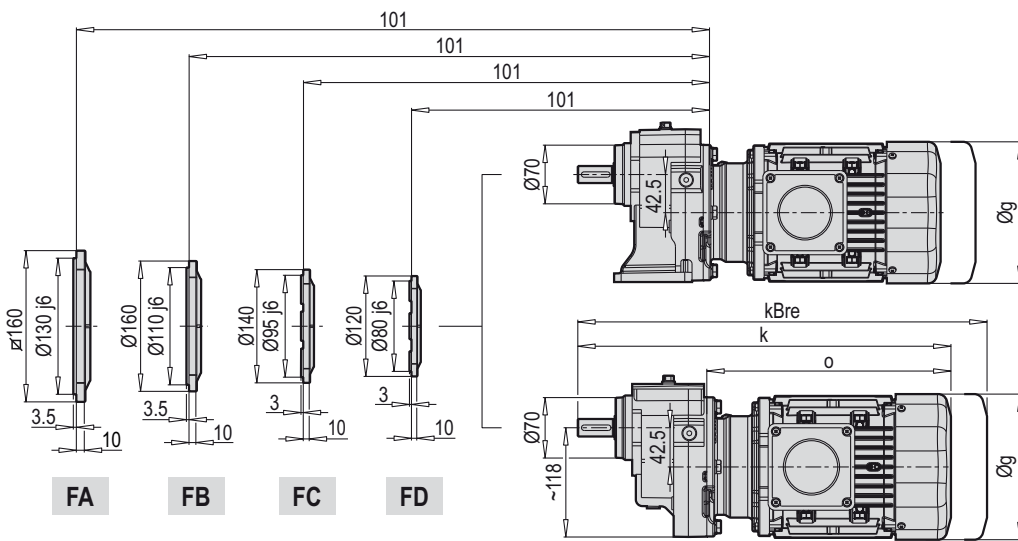
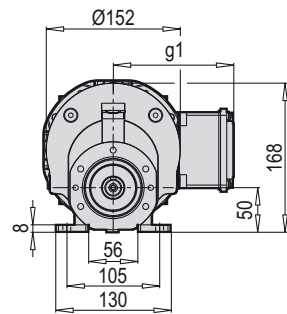
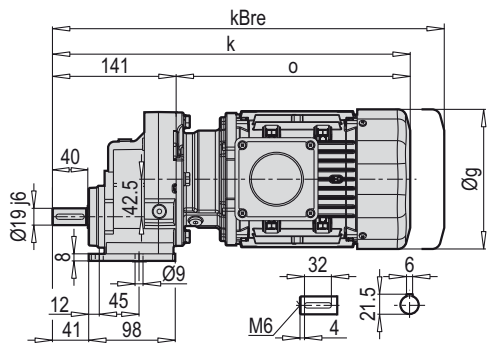

FA

FB

FC

FD

	71 M	80 M	90 S/L				
g	140	172	182				
g1	119	130.5	130				
k	382	406	489				
kBre	442	477	557				
o	241	265	348				

A 301 PAM B5/B14

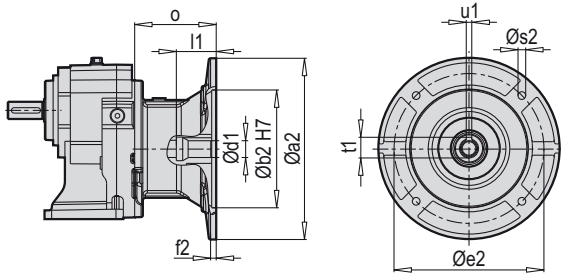

A 301 W

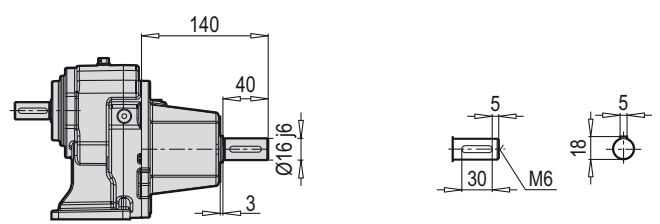

F 301 PAM B5/B14

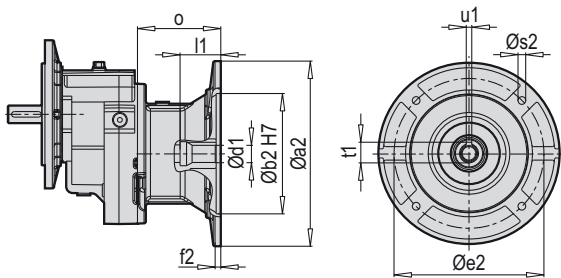

F 301 W

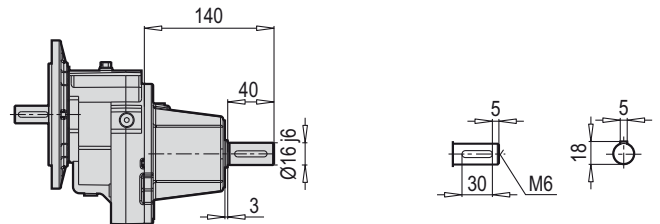

AF 301 PAM B5/B14

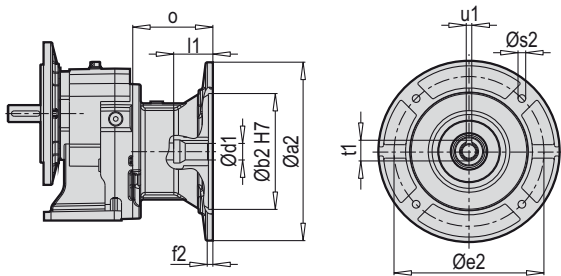

AF 301 W

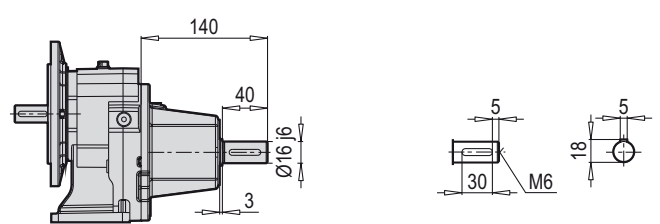

AF-M 301 PAM B5/B14

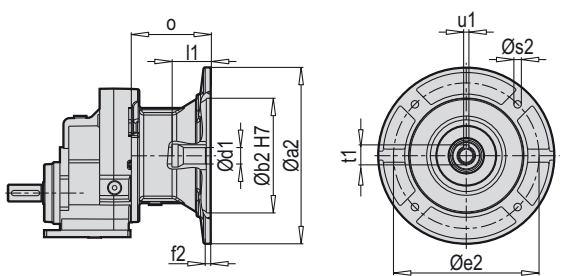

AF-M 301 W

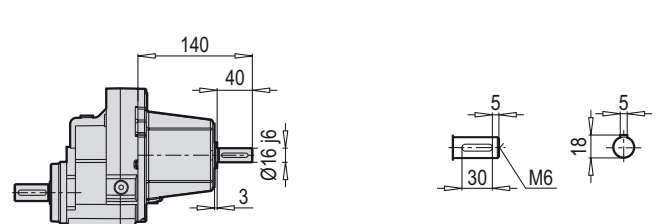

W ~ Kg	
A/F 301	10

Tip / Type Typ / Tipo Type / Tipo	PAM B5	Øa2	Øb2	Øe2	f2	Øs2	Ød1	l1	t1	u1	o
A/F 301	71	160	110	130	5	M8	14	32	16.3	5	69
	80	200	130	165	5	M10	19	42	21.8	6	90
	90	200	130	165	5	M10	24	52	27.3	8	90

~ Kg	
PAM B5	A/F 301
71	6
80	6.5
90	6.5

Tip / Type Typ / Tipo Type / Tipo	PAM B14	Øa2	Øb2	Øe2	f2	Øs2	Ød1	l1	t1	u1	o
A/F 301	63	90	60	75	2.5	6	11	32	16.3	5	69
	71	105	70	85	2.5	7	14	42	21.8	6	90
	80	120	80	100	3	7	19	52	27.3	8	90

~ Kg	
PAM B14	A/F 301
63	5
71	5.5
80	5.5

A 302-303

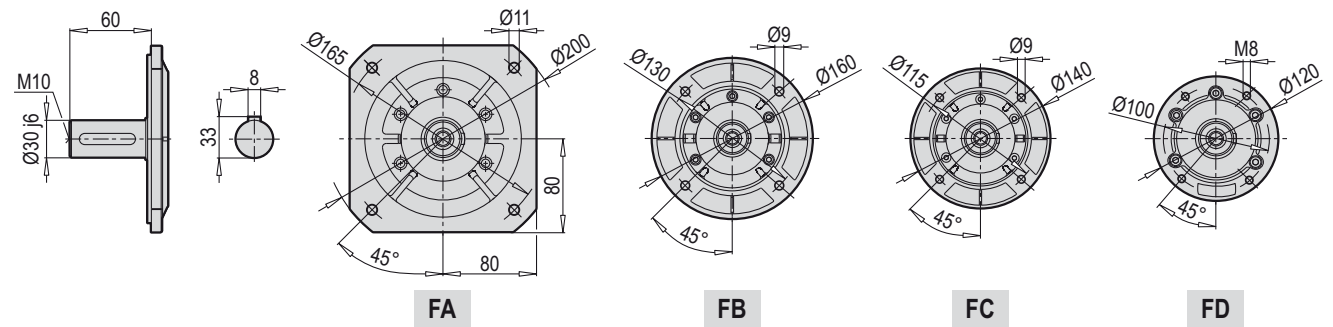
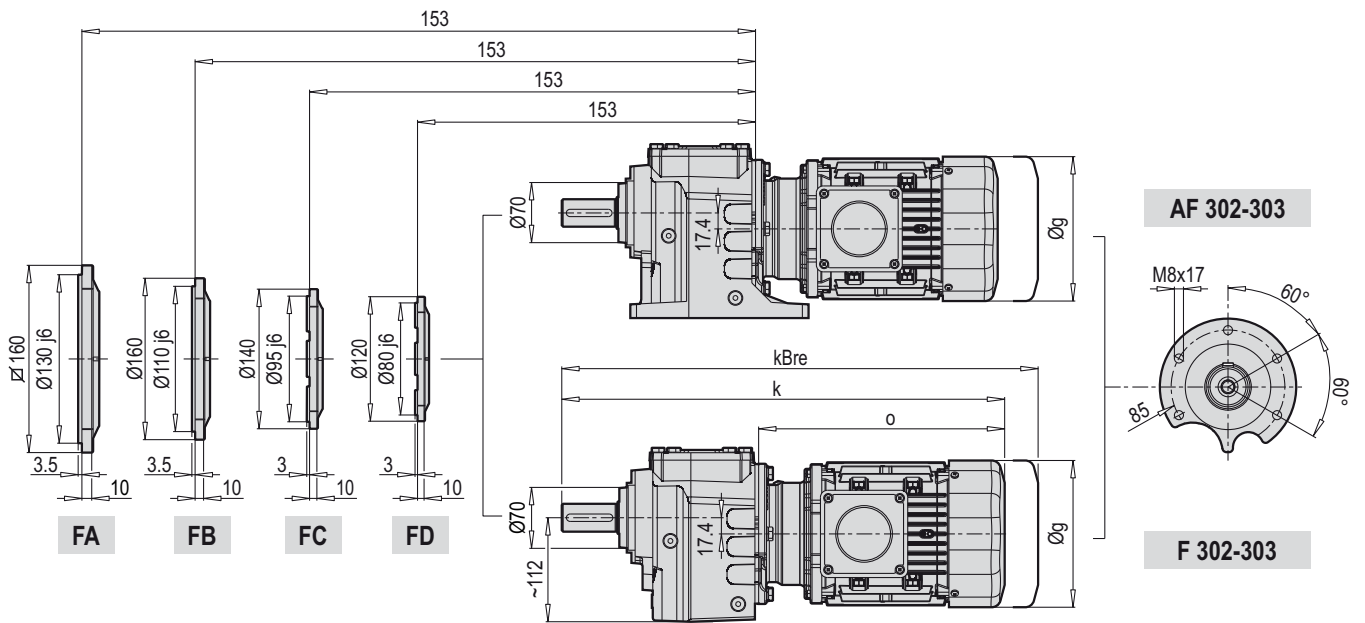
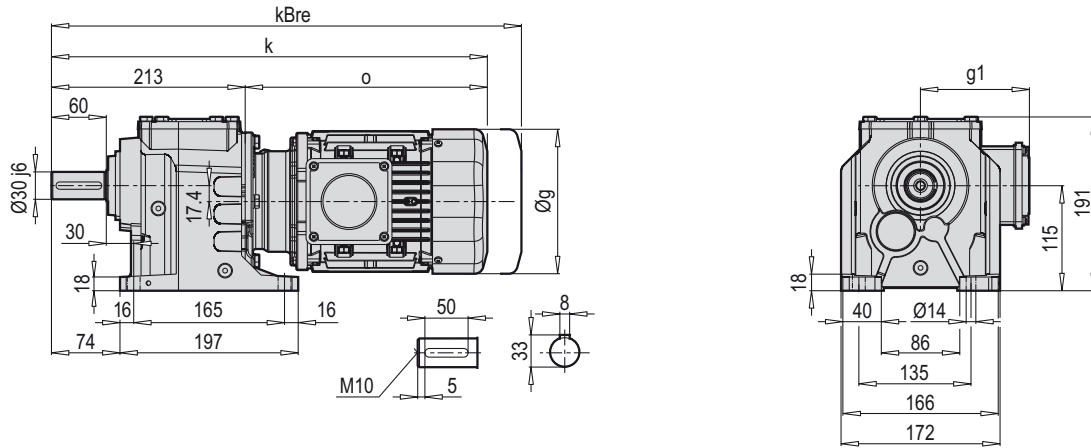

	63 M	71 M	80 M	90 S/L	100 L	112 M		
g	124	140	172	182	202	220		
g1	111	119	130.5	130	153	158.5		
k	425	454	478	561	592	596		
kBre	477	514	549	629	675	696		
o	212	241	265	348	379	383		

A 302-303 PAM B5/B14

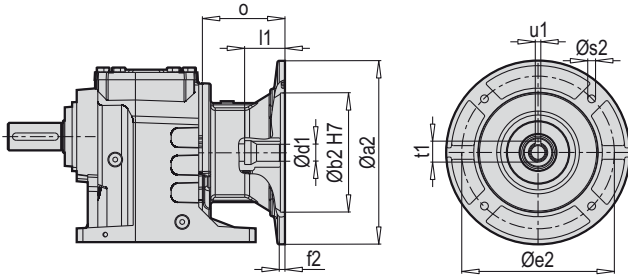

A 302-303 W

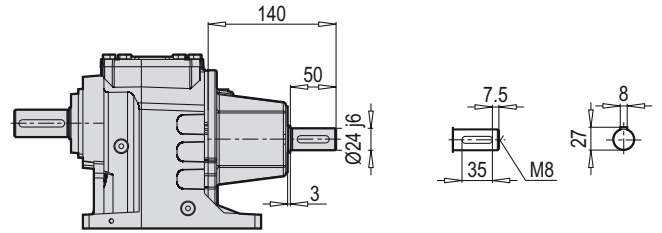

F 302-303 PAM B5/B14

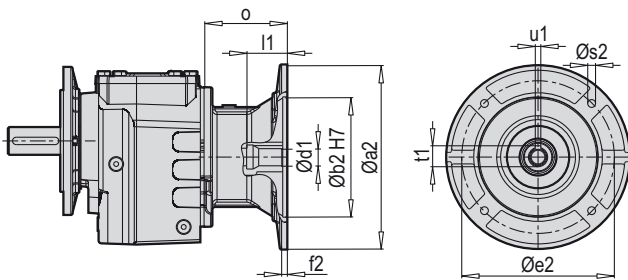

F 302-303 W

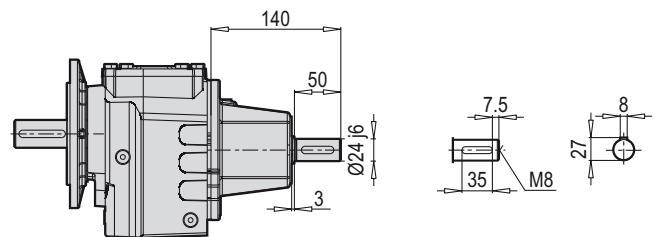

AF 302-303 PAM B5/B14

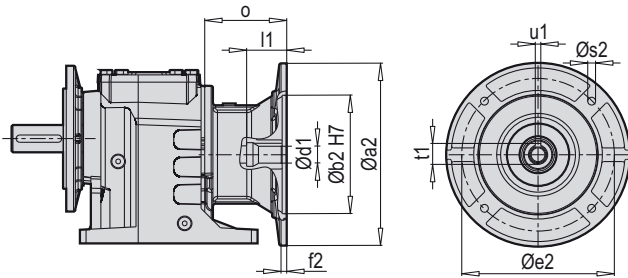

AF 302-303 W

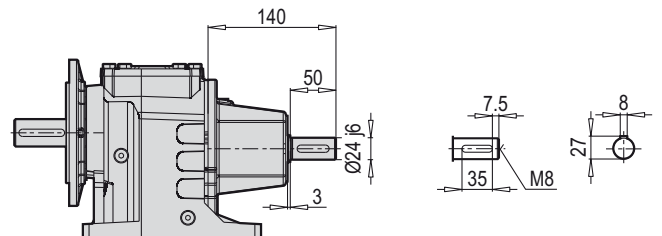

W ~ Kg	
A/F 302-303	17

Tip / Type Typ / Tipo Type / Tipo	PAM B5	Øa2	Øb2	Øe2	f2	Øs2	Ød1	l1	t1	u1	o
A/F 302 A/F 303	63	140	95	115	4.5	M8	11	25	12.8	4	57
	71	160	110	130	5	M8	14	32	16.3	5	69
	80	200	130	165	5	M10	19	42	21.8	6	90
	90	200	130	165	5	M10	24	52	27.3	8	90
	100	250	180	215	5.5	M12	28	62	31.3	8	105
	112	250	180	215	5.5	M12	28	62	31.3	8	105

~ Kg	
PAM B5	A/F 302-303
63	15
71	16
80	17
90	17
100	21
112	21

Tip / Type Typ / Tipo Type / Tipo	PAM B14	Øa2	Øb2	Øe2	f2	Øs2	Ød1	l1	t1	u1	o
A/F 302 A/F 303	63	90	60	75	2.5	6	11	25	12.8	4	57
	71	105	70	85	2.5	7	14	32	16.3	5	69
	80	120	80	100	3	7	19	42	21.8	6	90
	90	140	95	115	3	9	24	52	27.3	8	90
	100	160	110	130	3.5	9	28	62	31.3	8	105
	112	160	110	130	3.5	9	28	62	31.3	8	105

~ Kg	
PAM B14	A/F 302-303
63	14
71	15
80	16
90	16
100	17
112	17

A 351

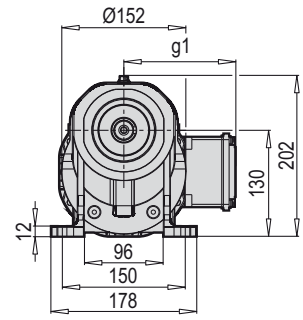
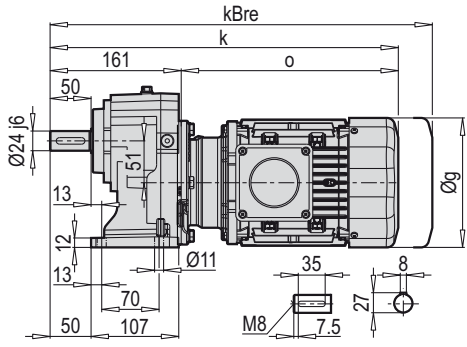

AF-M 351

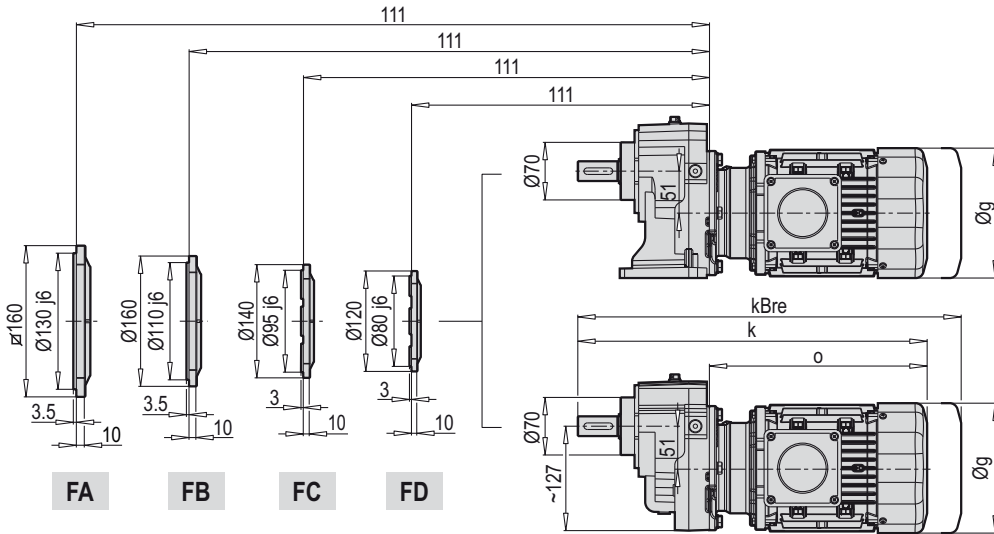
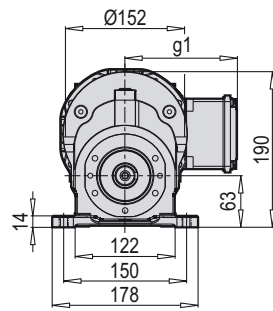
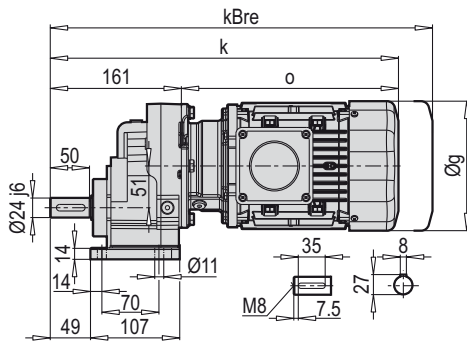

AF 351

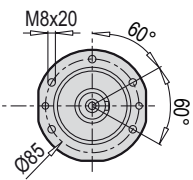

F 351

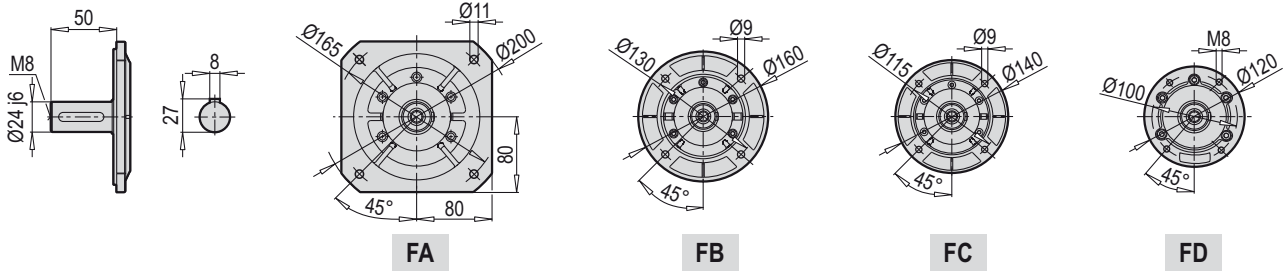

	80 M	90 S/L	100 L	112 M				
g	172	182	202	220				
g1	130.5	130	153	158.5				
k	426	509	540	544				
kBre	497	577	623	644				
o	265	348	379	383				

A 351 PAM B5/B14

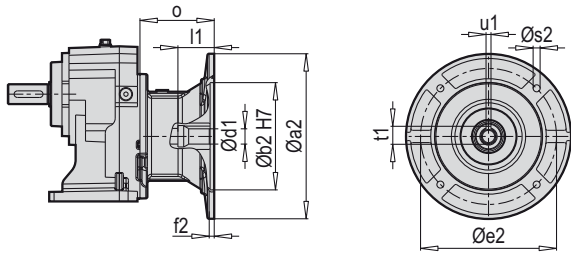

A 351 W

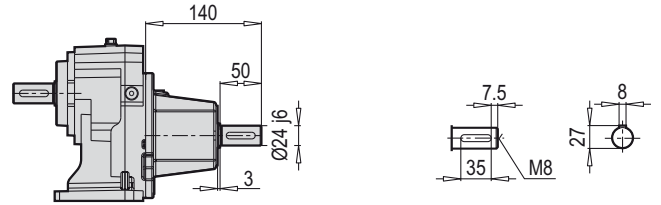

F 351 PAM B5/B14

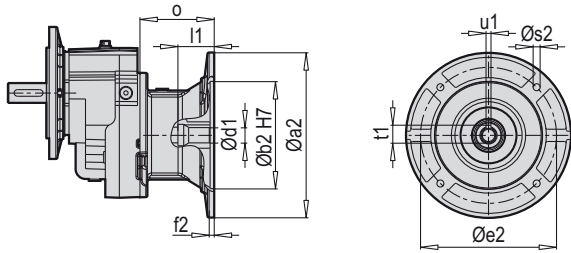

F 351 W

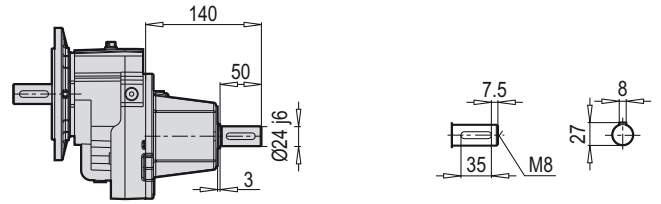

AF 351 PAM B5/B14

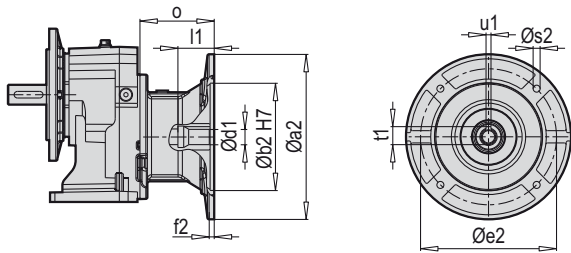

AF 351 W

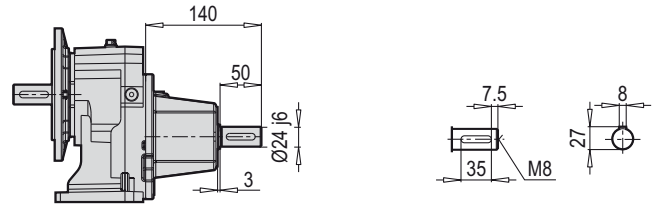

AF-M 351 PAM B5/B14

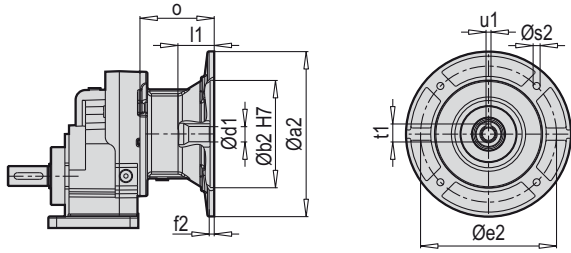

AF-M 351 W

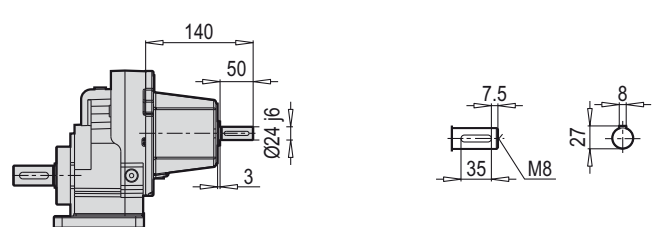

W ~ Kg	
A/F 351	12

Tip / Type Typ / Tipo Type / Tipo	PAM B5	Øa2	Øb2	Øe2	f2	Øs2	Ød1	l1	t1	u1	o
A/F 351	71	160	110	130	5	M8	14	32	16.3	5	69
	80	200	130	165	5	M10	19	42	21.8	6	90
	90	200	130	165	5	M10	24	52	27.3	8	90
	100	250	180	215	5.5	M12	28	62	31.3	8	105
	112	250	180	215	5.5	M12	28	62	31.3	8	105

~ Kg	
PAM B5	A/F 351
71	8
80	8.5
90	8.5
100	13
112	13

Tip / Type Typ / Tipo Type / Tipo	PAM B14	Øa2	Øb2	Øe2	f2	Øs2	Ød1	l1	t1	u1	o
A/F 351	71	105	70	85	2.5	7	14	32	16.3	5	69
	80	120	80	100	3	7	19	42	21.8	6	90
	90	140	95	115	3	9	24	52	27.3	8	90
	100	160	110	130	3.5	9	28	62	31.3	8	105
	112	160	110	130	3.5	9	28	62	31.3	8	105

~ Kg	
PAM B14	A/F 351
71	7
80	7.5
90	7.5
100	9.5
112	9.5

A 352-353

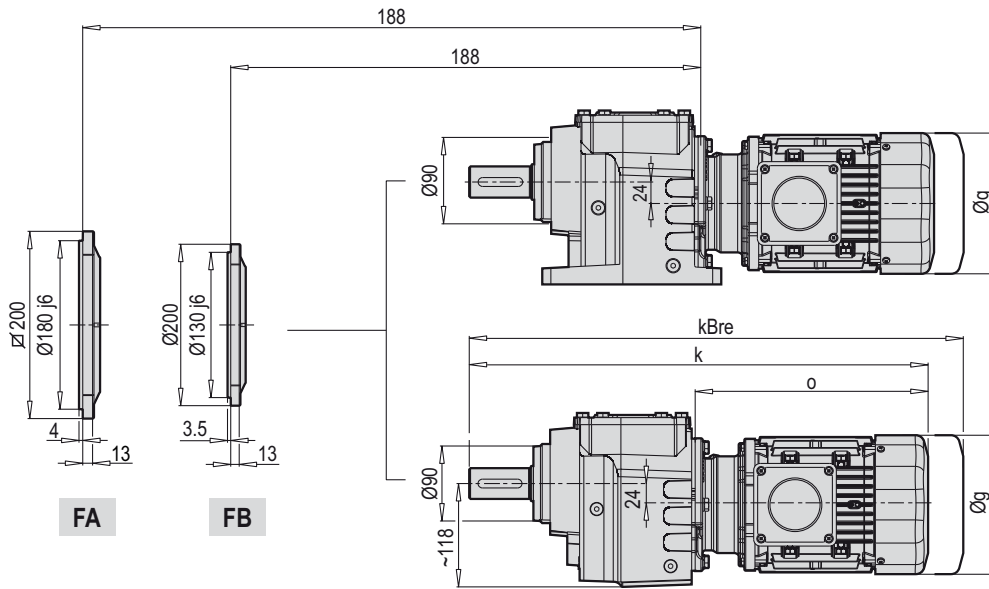
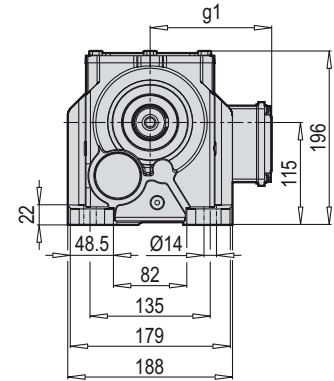
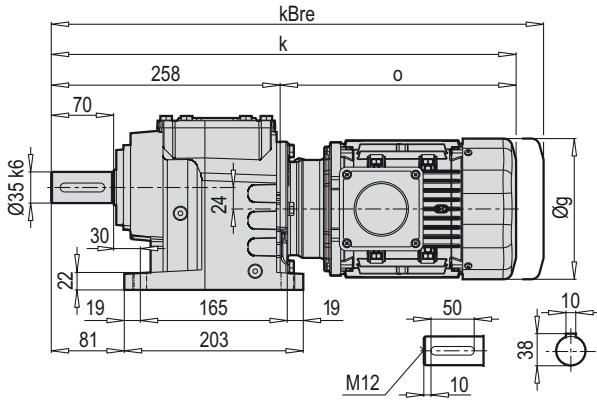

AF 352-353

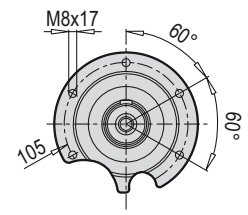

F 352-353

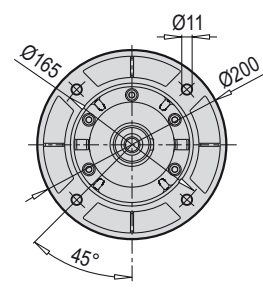
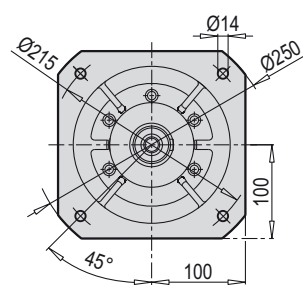
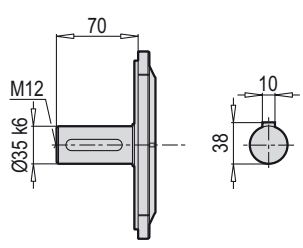

FA

FB

	63 M	71 M	80 M	90 S/L	100 L	112 M		
g	124	140	172	182	202	220		
g1	111	119	130.5	130	153	158.5		
k	470	499	523	606	637	641		
kBre	522	559	594	674	720	741		
o	212	241	265	348	379	383		

A 352-353 PAM B5/B14

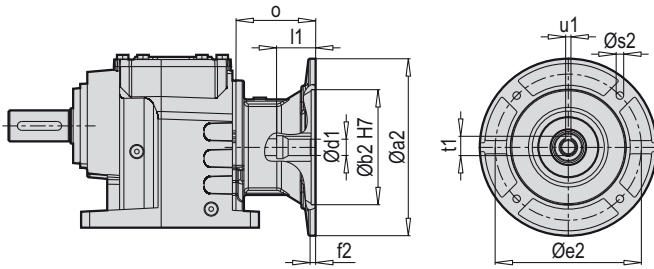

A 352-353 W

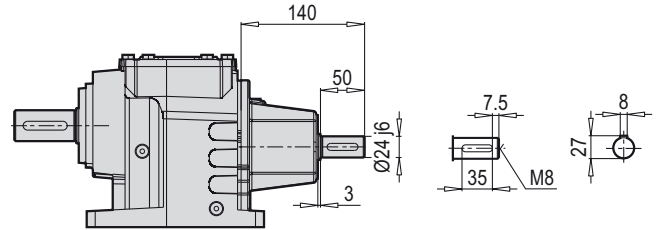

F 352-353 PAM B5/B14

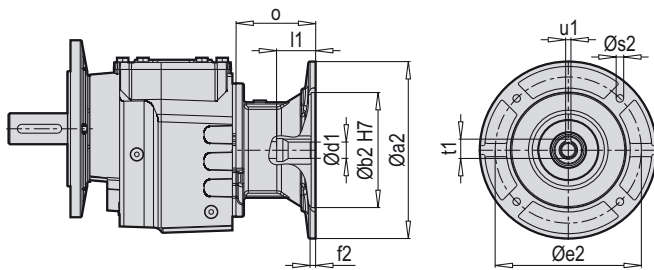

F 352-353 W

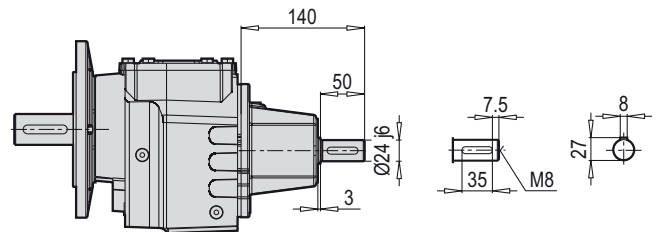

AF 352-353 PAM B5/B14

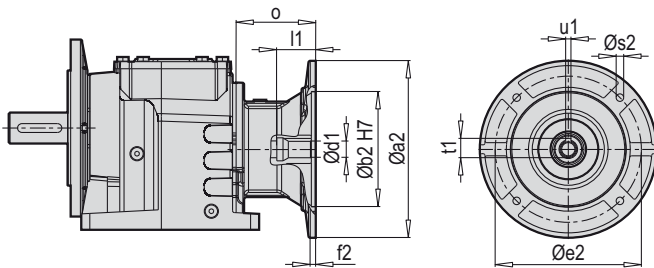

AF 352-353 W

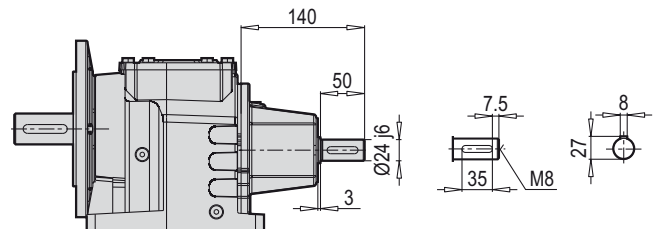

W ~ Kg	
A/F 352-353	22

Tip / Type Typ / Tipo Type / Tipo	PAM B5	Øa2	Øb2	Øe2	f2	Øs2	Ød1	l1	t1	u1	o
A/F 352 A/F 353	63	140	95	115	4.5	M8	11	25	12.8	4	57
	71	160	110	130	5	M8	14	32	16.3	5	69
	80	200	130	165	5	M10	19	42	21.8	6	90
	90	200	130	165	5	M10	24	52	27.3	8	90
	100	250	180	215	5.5	M12	28	62	31.3	8	105
	112	250	180	215	5.5	M12	28	62	31.3	8	105

~ Kg	
PAM B5	A/F 352-353
63	20
71	21
80	22
90	22
100	26
112	26

Tip / Type Typ / Tipo Type / Tipo	PAM B14	Øa2	Øb2	Øe2	f2	Øs2	Ød1	l1	t1	u1	o
A/F 352 A/F 353	63	90	60	75	2.5	6	11	25	12.8	4	57
	71	105	70	85	2.5	7	14	32	16.3	5	69
	80	120	80	100	3	7	19	42	21.8	6	90
	90	140	95	115	3	9	24	52	27.3	8	90
	100	160	110	130	3.5	9	28	62	31.3	8	105
	112	160	110	130	3.5	9	28	62	31.3	8	105

~ Kg	
PAM B14	A/F 352-353
63	19
71	20
80	21
90	21
100	23
112	23

A 401

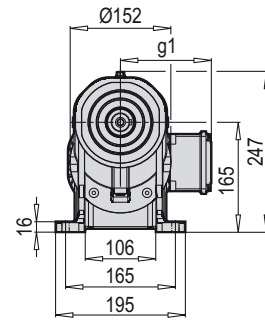
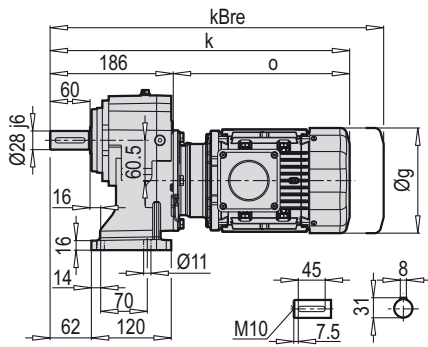

AF-M 401

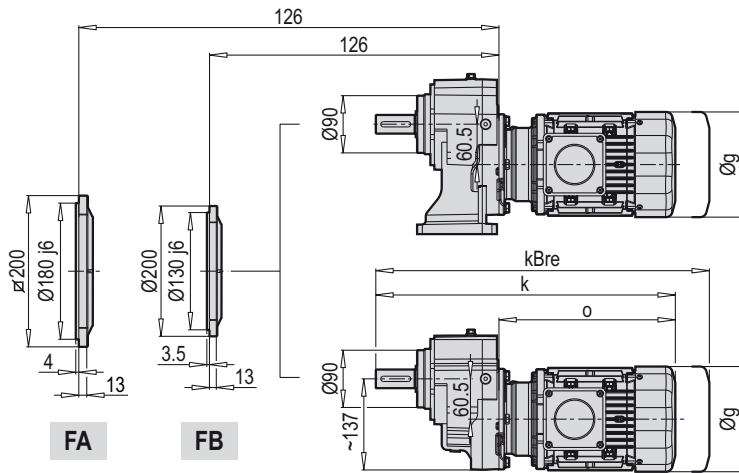
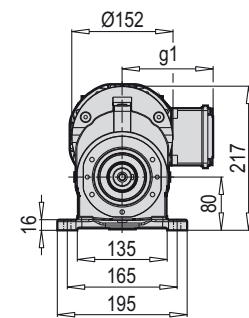
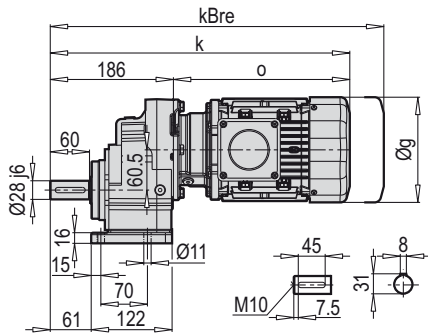

AF 401

F 401

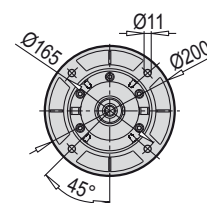
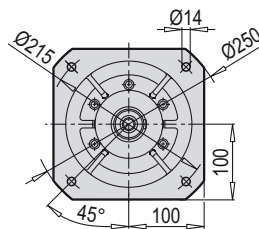
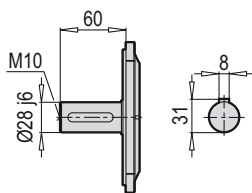

FA

FB

	90 S/L	100 L	112 M					
g	182	202	220					
g1	130	153	158.5					
k	534	565	569					
kBre	602	648	669					
o	348	379	383					

A 401 PAM B5/B14

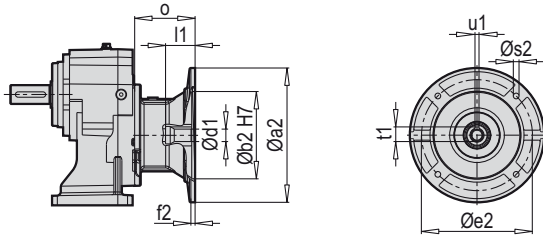

A 401 W

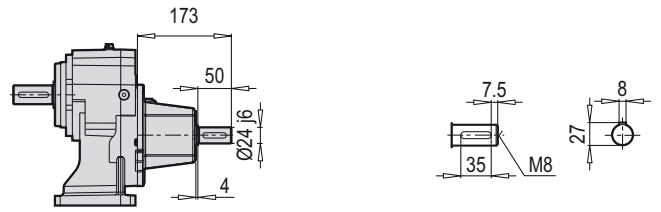

F 401 PAM B5/B14

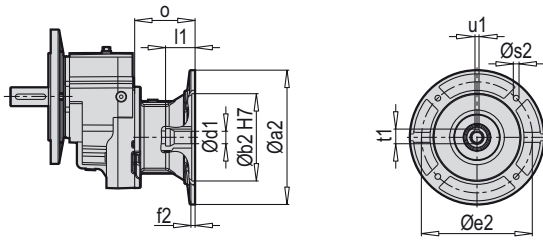

F 401 W

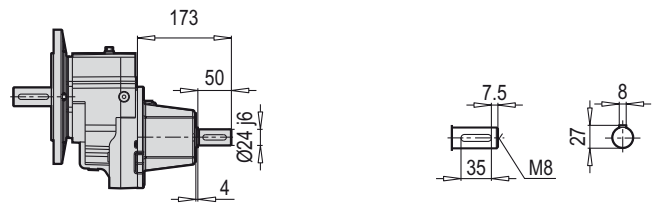

AF 401 PAM B5/B14

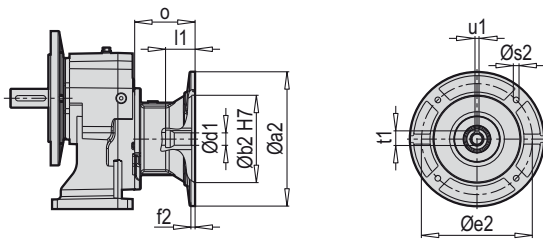

AF 401 W

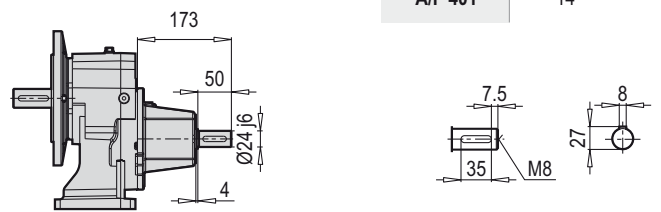

W ~ Kg	
A/F 401	14

AF-M 401 PAM B5/B14

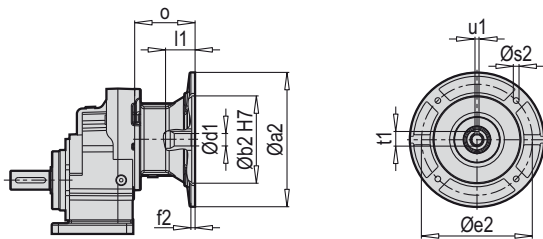

AF-M 401 W

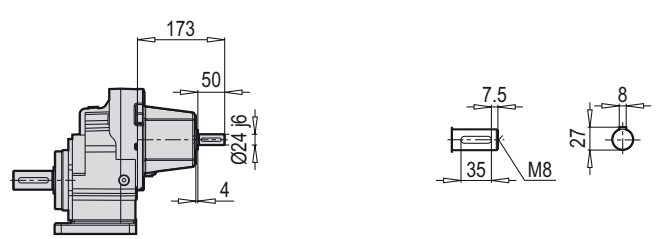

Tip / Type Typ / Tipo Type / Tipo	PAM B5	Øa2	Øb2	Øe2	f2	Øs2	Ød1	l1	t1	u1	o
A/F 401	80	200	130	165	5	M10	19	42	21.8	6	90
	90	200	130	165	5	M10	24	52	27.3	8	90
	100	250	180	215	5.5	M12	28	62	31.3	8	105
	112	250	180	215	5.5	M12	28	62	31.3	8	105

~ Kg	
PAM B5	A/F 401
80	11
90	11
100	15.5
112	15.5

Tip / Type Typ / Tipo Type / Tipo	PAM B14	Øa2	Øb2	Øe2	f2	Øs2	Ød1	l1	t1	u1	o
A/F 401	80	120	80	100	3	7	19	42	21.8	6	90
	90	140	95	115	3	9	24	52	27.3	8	90
	100	160	110	130	3.5	9	28	62	31.3	8	105
	112	160	110	130	3.5	9	28	62	31.3	8	105

~ Kg	
PAM B14	A/F 401
80	10
90	10
100	12
112	12

A 402-403

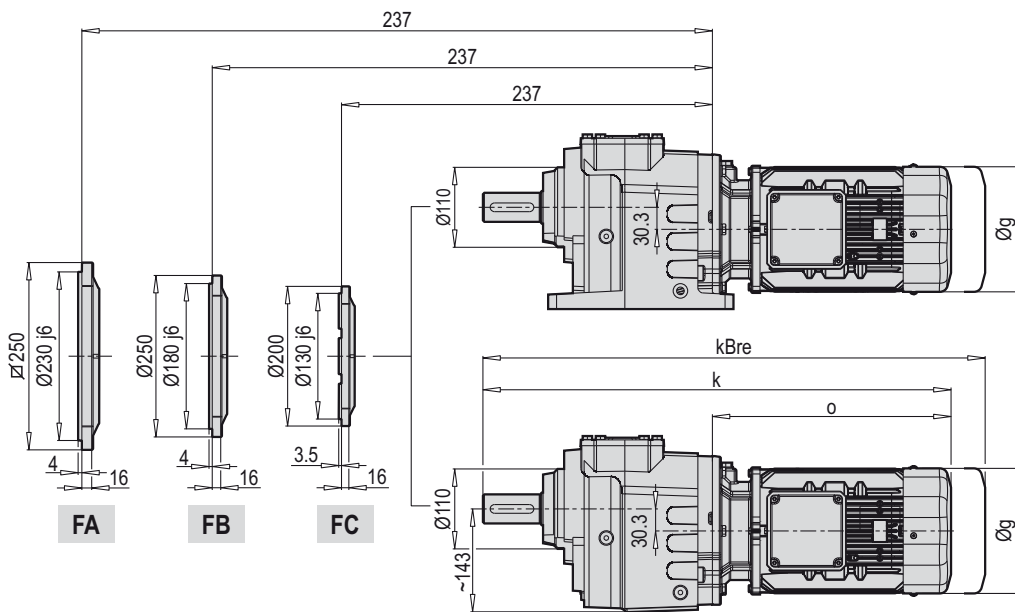
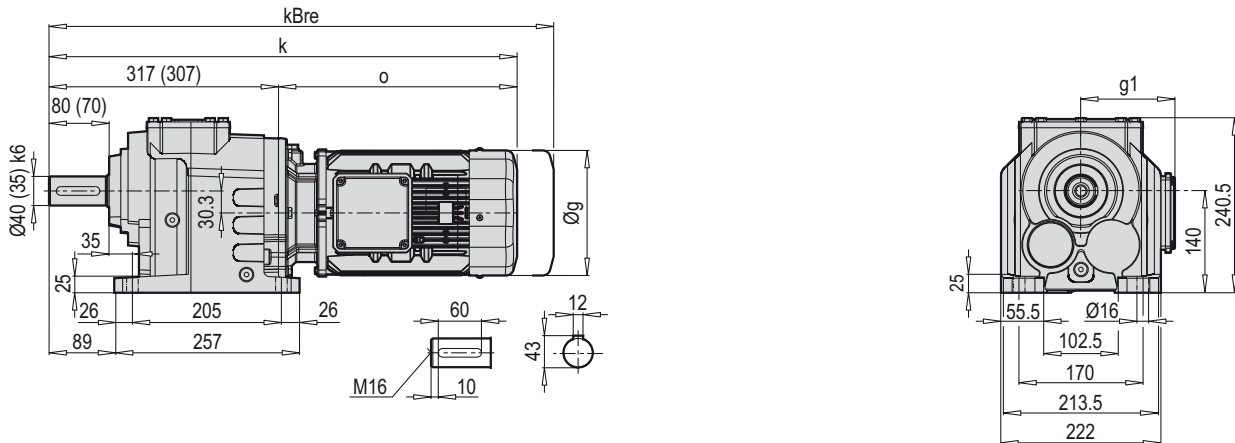

AF 402-403

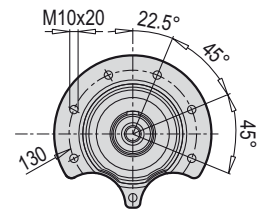

F 402-403

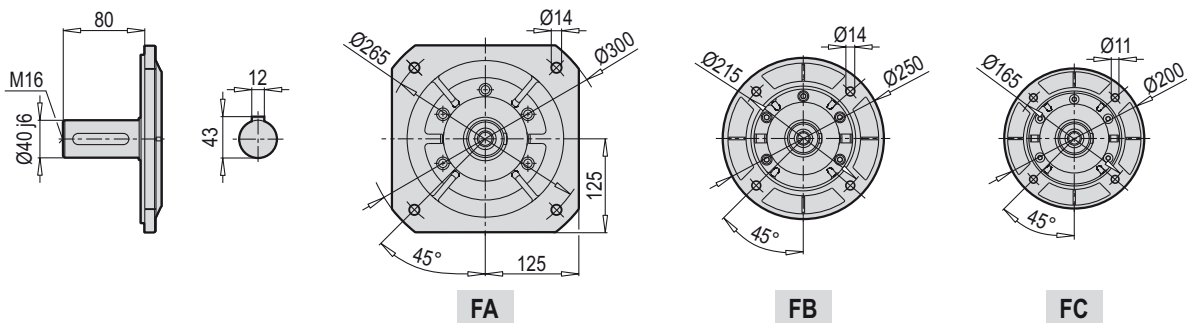

	71 M	80 M	90 S/L	100 L	112 M	132 S	132 M	
g	140	172	182	202	220	270.5	270.5	
g1	119	130.5	130	153	158.5	187.5	187.5	
k	538 (528)	563 (553)	646 (636)	699 (689)	697 (687)	771 (761)	771 (761)	
kBre	598 (588)	634 (624)	714 (704)	783 (773)	798 (788)	870 (860)	890 (880)	
o	221	246	329	382	380	454	454	

A 402-403 PAM B5/B14

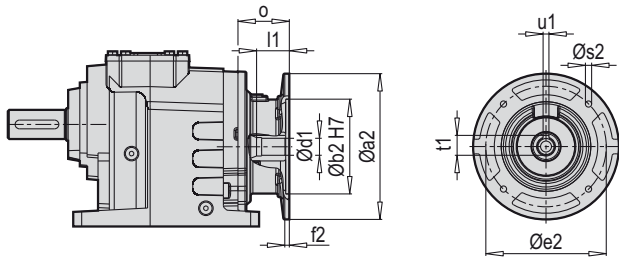

A 402-403 W

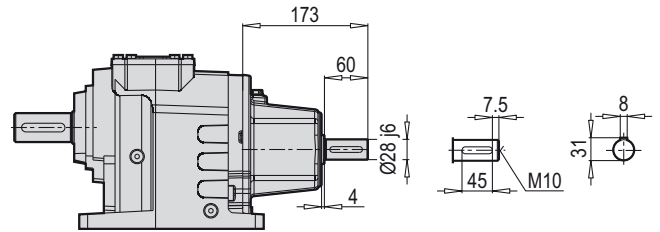

F 402-403 PAM B5/B14

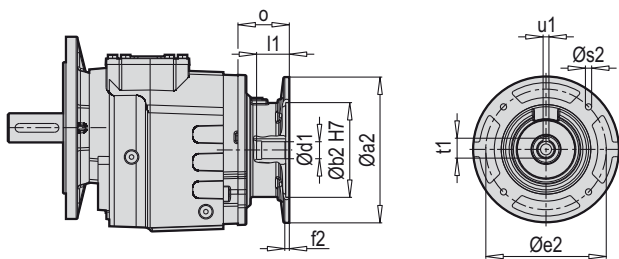

F 402-403 W

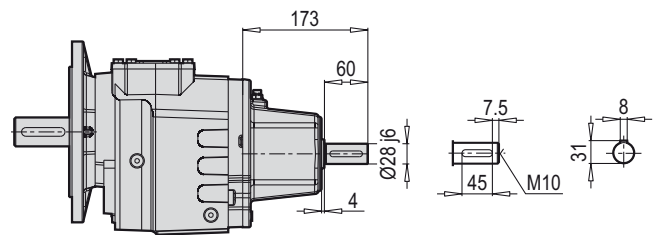

AF 402-403 PAM B5/B14

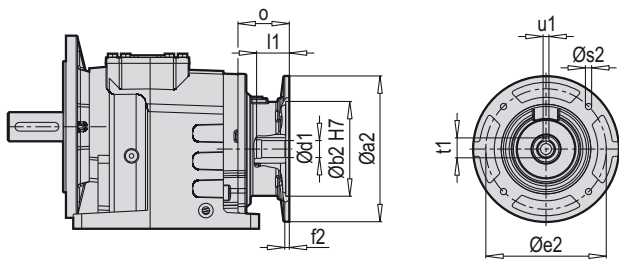

AF 402-403 W

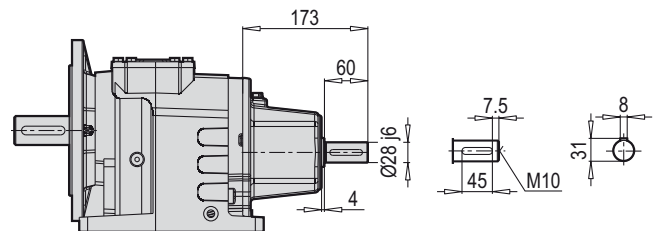

W ~ Kg	
A/F 402-403	37

Tip / Type Typ / Tipo Type / Tipo	PAM B5	Øa2	Øb2	Øe2	f2	Øs2	Ød1	l1	t1	u1	o
A/F 402 A/F 403	71	160	110	130	5	M8	14	32	16.3	5	49
	80	200	130	165	5	M10	19	42	21.8	6	70
	90	200	130	165	5	M10	24	52	27.3	8	70
	100	250	180	215	5.5	M12	28	62	31.3	8	85
	112	250	180	215	5.5	M12	28	62	31.3	8	85
	132	300	230	265	5.5	M12	38	82	41.3	10	110

~ Kg	
PAM B5	A/F 402-403
71	32
80	35
90	35
100	37
112	37
132	41

Tip / Type Typ / Tipo Type / Tipo	PAM B14	Øa2	Øb2	Øe2	f2	Øs2	Ød1	l1	t1	u1	o
A/F 402 A/F 403	71	105	70	85	2.5	7	14	32	16.3	5	49
	80	120	80	100	3	7	19	42	21.8	6	70
	90	140	95	115	3	9	24	52	27.3	8	70
	100	160	110	130	3.5	9	28	62	31.3	8	85
	112	160	110	130	3.5	9	28	62	31.3	8	85
	132	200	130	165	3.5	11	38	82	41.3	10	110

~ Kg	
PAM B14	A/F 402-403
71	30
80	31
90	31
100	32
112	32
132	38

A 501

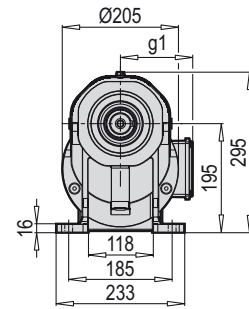
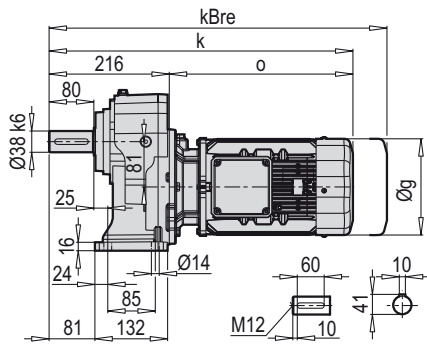

AF-M 501

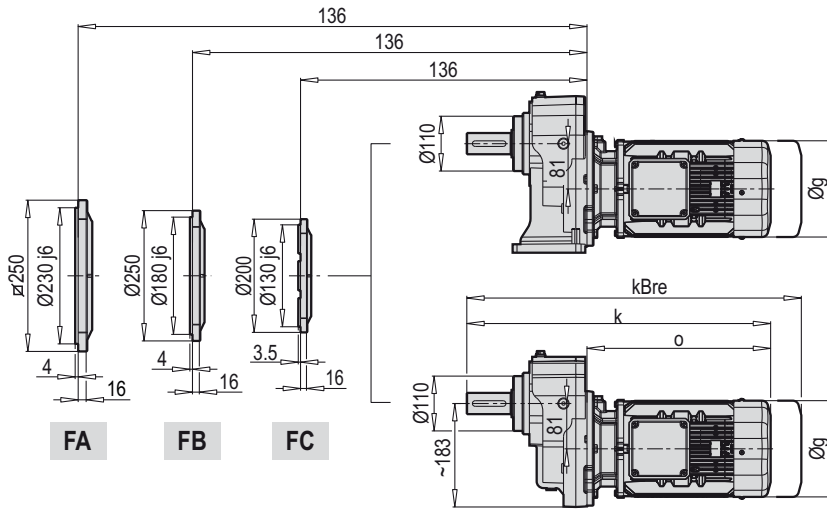
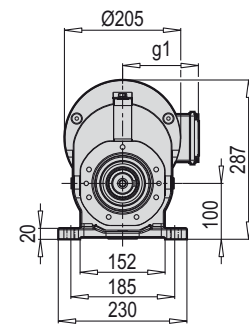
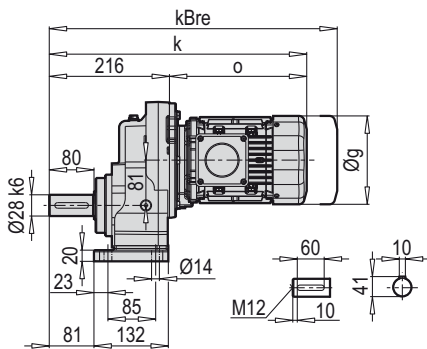

AF 501

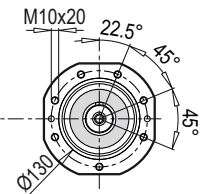

F 501

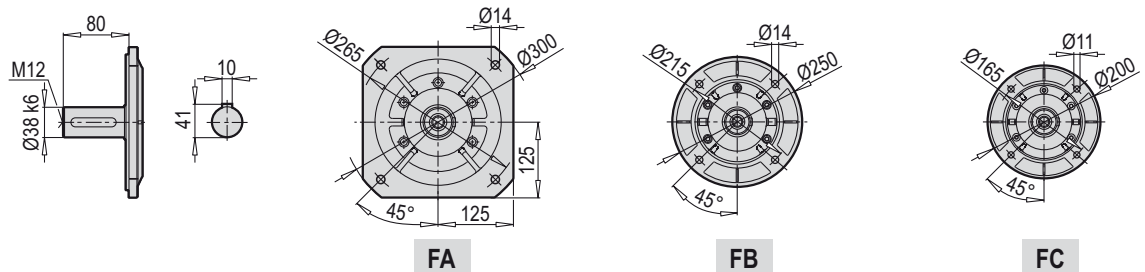

	100 L	112 M	132 S	132 M				
g	202	220	270.5	270.5				
g1	153	158.5	187.5	187.5				
k	598	596	670	670				
kBre	682	697	769	789				
o	382	380	454	454				

A 501 PAM B5/B14

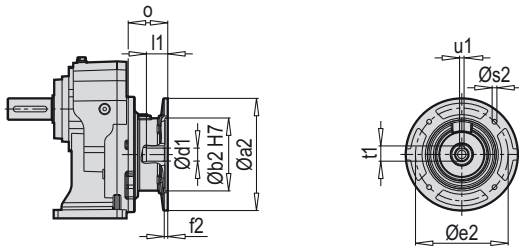

A 501 W

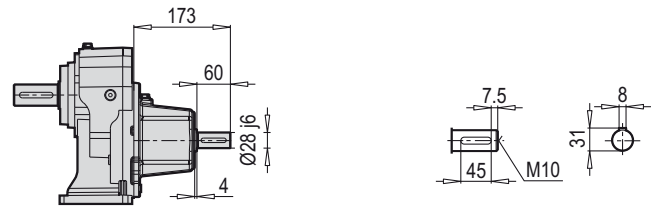

F 501 PAM B5/B14

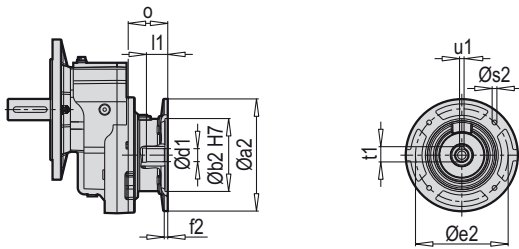

F 501 W

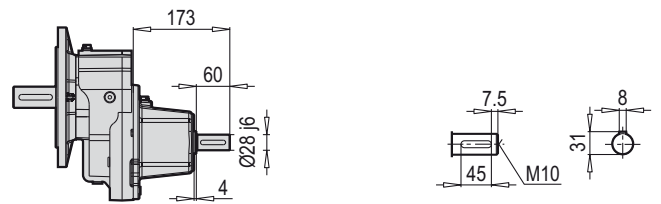

AF 501 PAM B5/B14

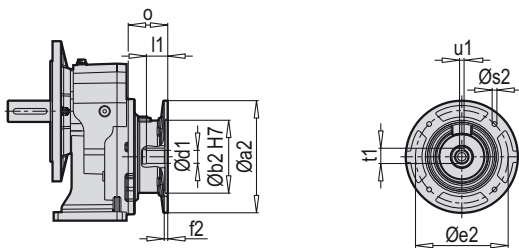

AF 501 W

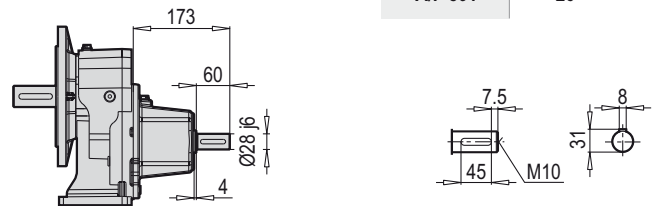

W ~ Kg	
A/F 501	26

AF-M 501 PAM B5/B14

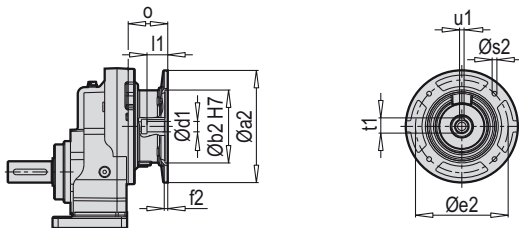

AF-M 501 W

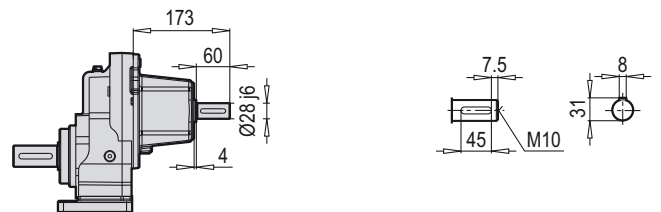

Tip / Type Typ / Tipo Type / Tipo	PAM B5	Øa2	Øb2	Øe2	f2	Øs2	Ød1	l1	t1	u1	o
A/F 501	80	200	130	165	5	M10	19	42	21.8	6	70
	90	200	130	165	5	M10	24	52	27.3	8	70
	100	250	180	215	5.5	M12	28	62	31.3	8	85
	112	250	180	215	5.5	M12	28	62	31.3	8	85
	132	300	230	265	5.5	M12	38	82	41.3	10	110

~ Kg	
PAM B5	A/F 501
80	22
90	22
100	25
112	25
132	27

Tip / Type Typ / Tipo Type / Tipo	PAM B14	Øa2	Øb2	Øe2	f2	Øs2	Ød1	l1	t1	u1	o
A/F 501	80	120	80	100	3	7	19	42	21.8	6	70
	90	140	95	115	3	9	24	52	27.3	8	70
	100	160	110	130	3.5	9	28	62	31.3	8	85
	112	160	110	130	3.5	9	28	62	31.3	8	85
	132	200	130	165	3.5	11	38	82	41.3	10	110

~ Kg	
PAM B14	A/F 501
80	18.5
90	18.5
100	21
112	21
132	24

A 502-503

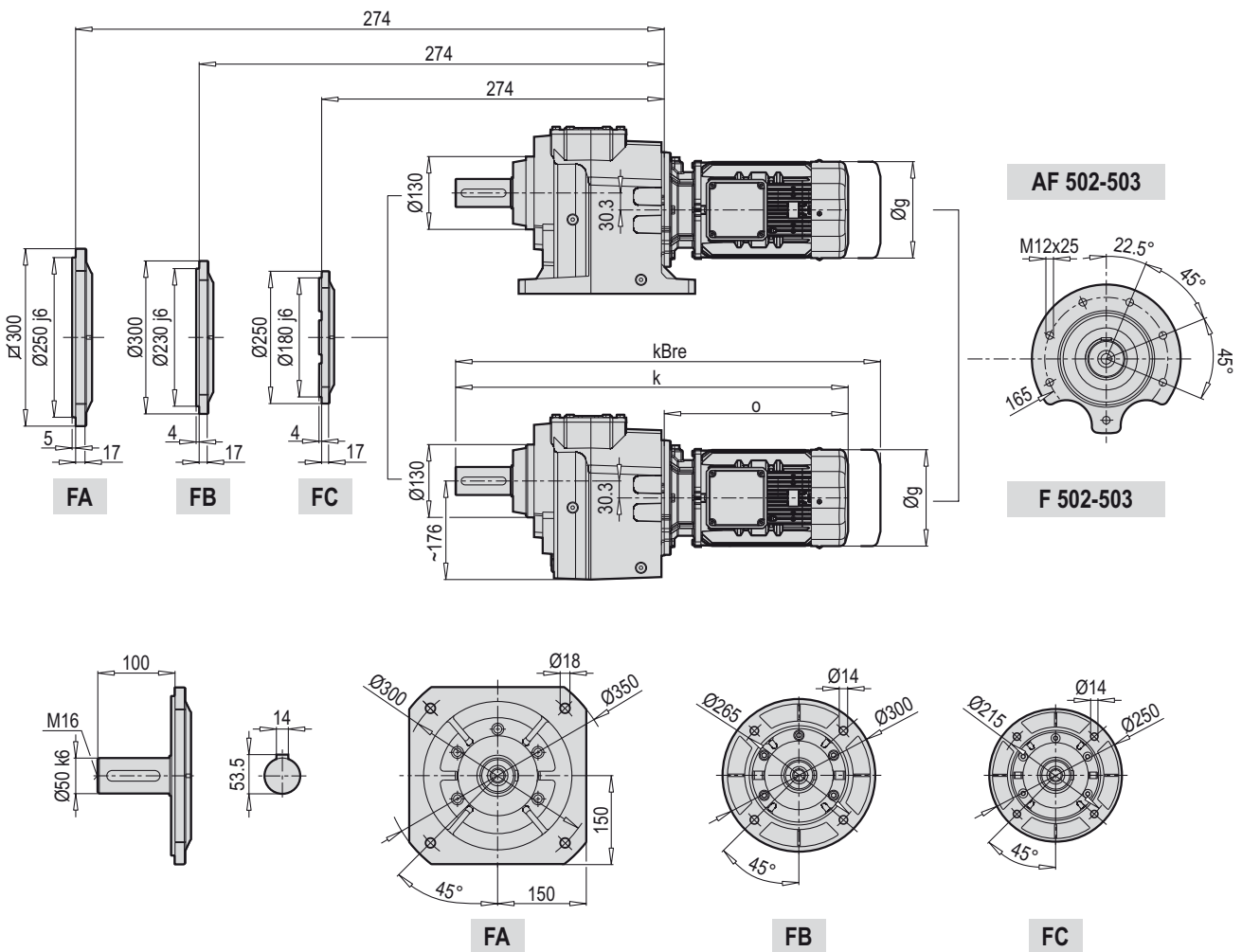
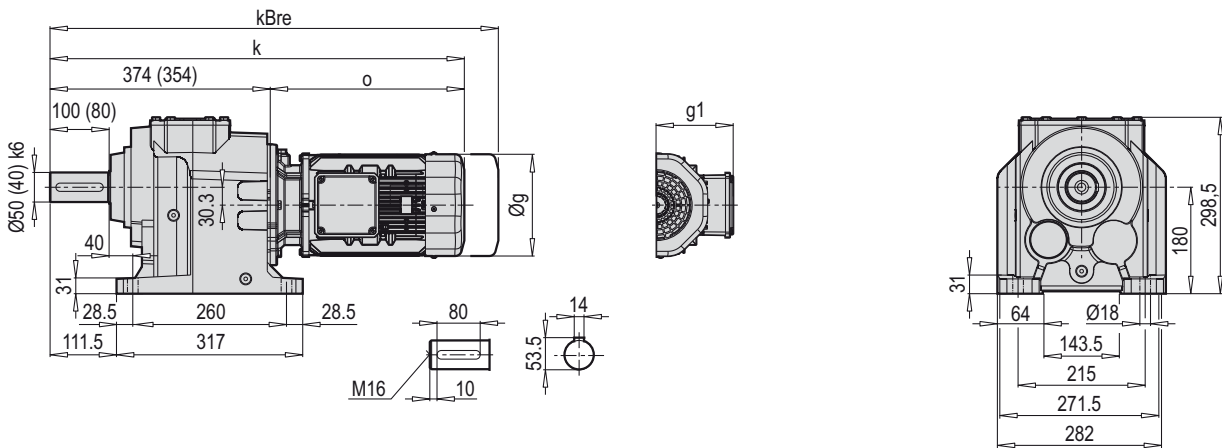

	80 M	90 S/L	100 L	112 M	132 S	132 M	160 M/L	
g	172	182	202	220	270.5	270.5	321.5	
g1	130.5	130	153	158.5	187.5	187.5	214	
k	620 (600)	703 (683)	756 (736)	754 (734)	828 (808)	828 (808)	909 (889)	
kBre	691 (671)	771 (751)	840 (820)	855 (835)	927 (907)	947 (927)	1013 (993)	
o	246	329	382	380	454	454	535	

A 502-503 PAM B5/B14

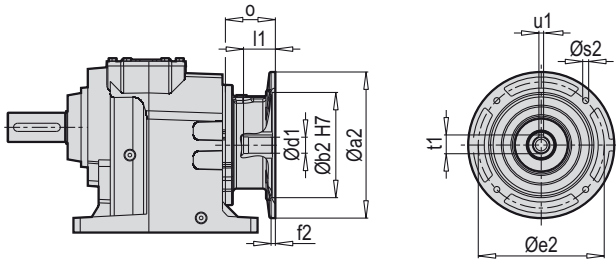

A 502-503 W

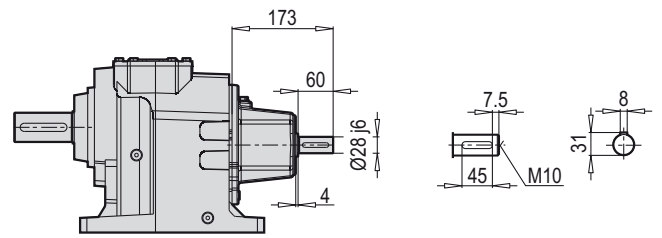

F 502-503 PAM B5/B14

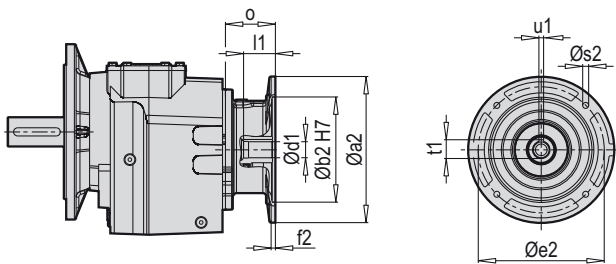

F 502-503 W

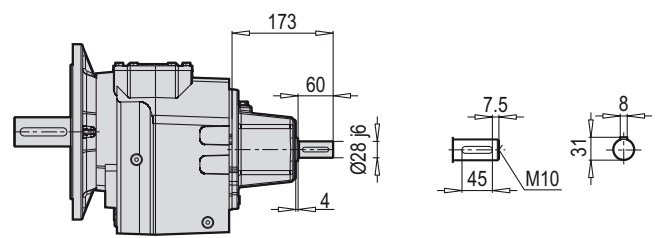

AF 502-503 PAM B5/B14

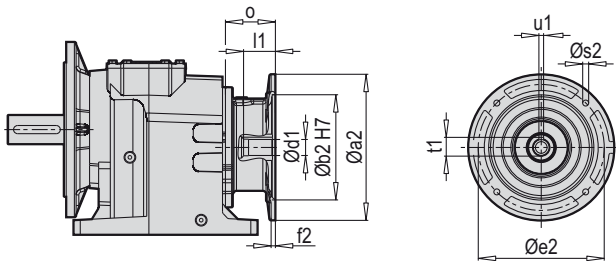

AF 502-503 W

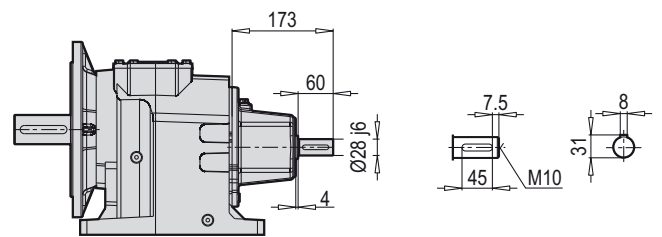

W ~ Kg	
A/F 502-503	54

Tip / Type Typ / Tipo Type / Tipo	PAM B5	Øa2	Øb2	Øe2	f2	Øs2	Ød1	l1	t1	u1	o
A/F 502 A/F 503	80	200	130	165	5	M10	19	42	21.8	6	70
	90	200	130	165	5	M10	24	52	27.3	8	70
	100	250	180	215	5.5	M12	28	62	31.3	8	85
	112	250	180	215	5.5	M12	28	62	31.3	8	85
	132	300	230	265	5.5	M12	38	82	41.3	10	110
	160	350	250	300	7	M16	42	112	45.3	12	158

~ Kg	
PAM B5	A/F 502-503
80	52
90	52
100	54
112	54
132	58
160	65

Tip / Type Typ / Tipo Type / Tipo	PAM B14	Øa2	Øb2	Øe2	f2	Øs2	Ød1	l1	t1	u1	o
A/F 502 A/F 503	80	120	80	100	3	7	19	42	21.8	6	70
	90	140	95	115	3	9	24	52	27.3	8	70
	100	160	110	130	3.5	9	28	62	31.3	8	85
	112	160	110	130	3.5	9	28	62	31.3	8	85
	132	200	130	165	3.5	11	38	82	41.3	10	110

~ Kg	
PAM B14	A/F 502-503
80	48
90	48
100	50
112	50
132	55

A 601

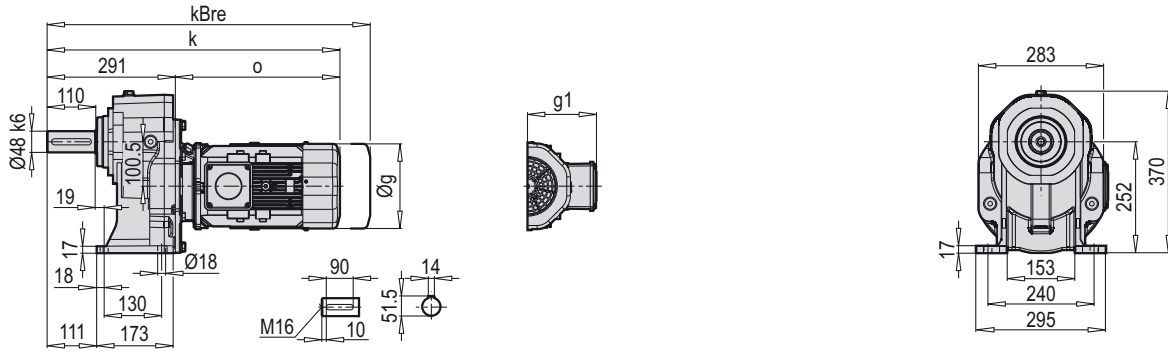

AF-M 601

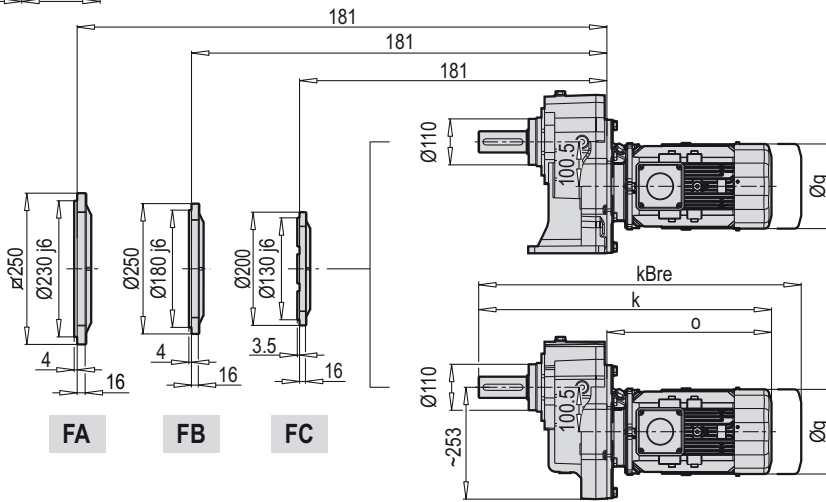
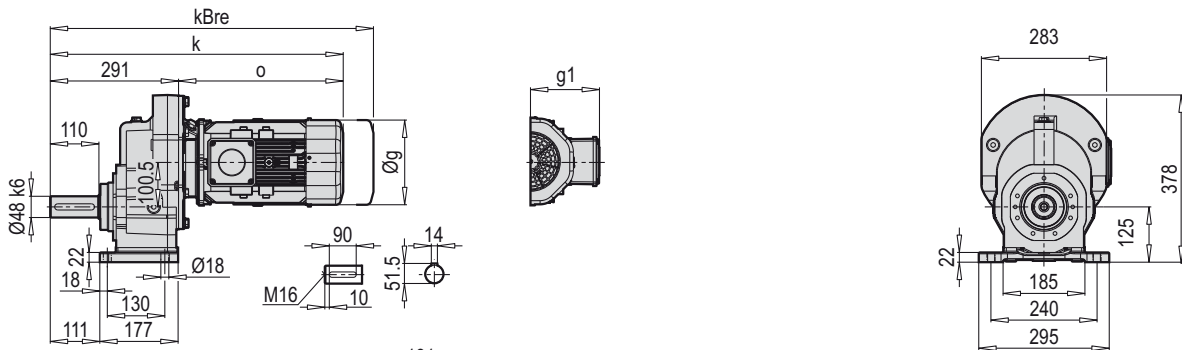

AF 601

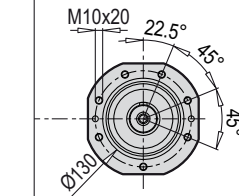

F 601

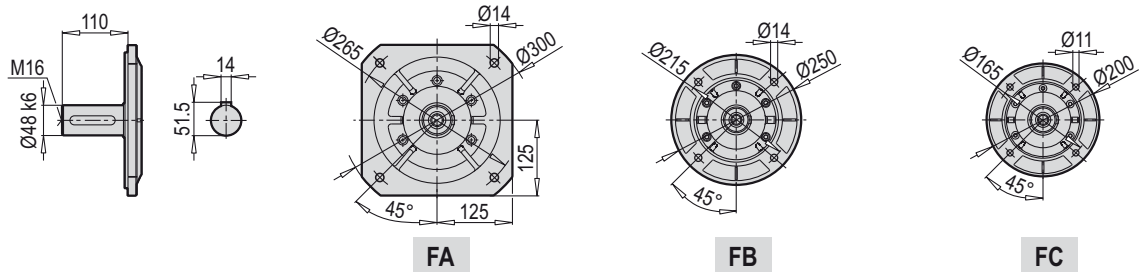

	112 M	132 S	132 M	160 M/L	180 M/L	200 L		
g	220	270.5	270.5	321.5	363	363		
g1	158.5	187.5	187.5	214	249	249		
k	662	735	735	816	906	906		
kBre	762	835	855	921	1025	1025		
o	371	444	444	525	615	615		

A 601 PAM B5/B14

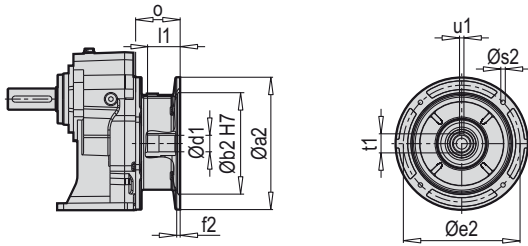

A 601 W

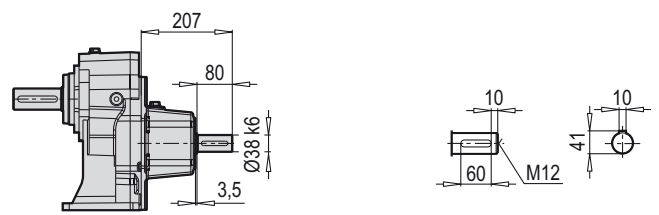

F 601 PAM B5/B14

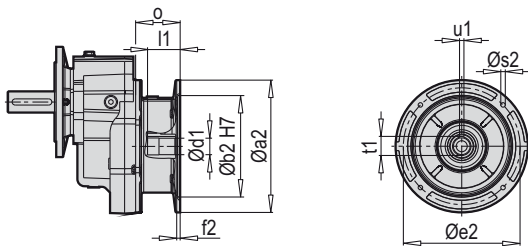

F 601 W

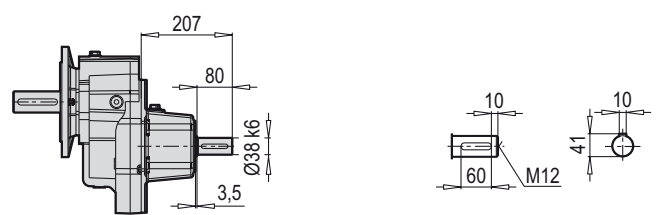

AF 601 PAM B5/B14

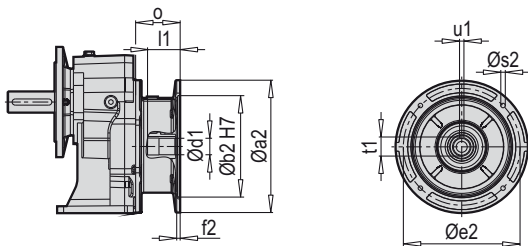

AF 601 W

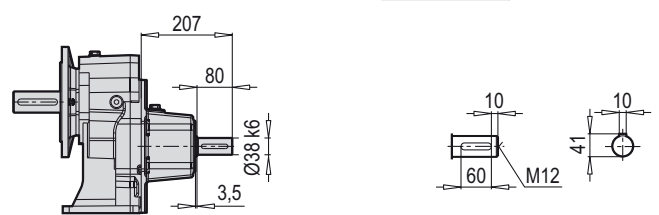

AF-M 601 PAM B5/B14

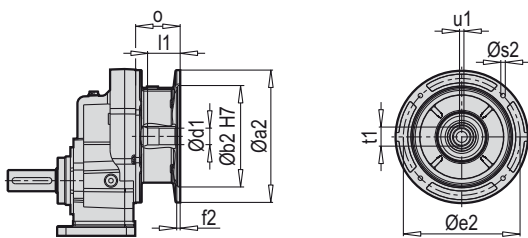

AF-M 601 W

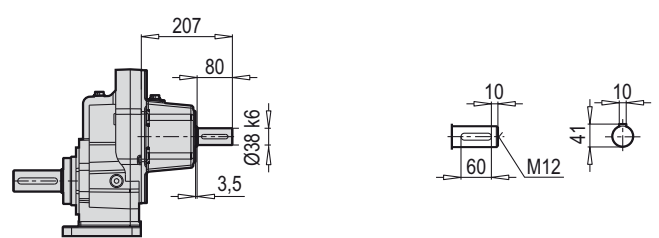

W ~ Kg	
A/F 601	45

Tip / Type Typ / Tipo Type / Tipo	PAM B5	Øa2	Øb2	Øe2	f2	Øs2	Ød1	l1	t1	u1	o
A/F 601	100	250	180	215	5.5	M12	28	62	31.3	8	76
	112	250	180	215	5.5	M12	28	62	31.3	8	76
	132	300	230	265	5.5	M12	38	82	41.3	10	101
	160	350	250	300	7	M16	42	112	45.3	12	148
	180	350	250	300	7	M16	48	112	51.8	14	148

~ Kg	
PAM B5	A/F 601
100	37
112	37
132	40
160	47
180	47

Tip / Type Typ / Tipo Type / Tipo	PAM B14	Øa2	Øb2	Øe2	f2	Øs2	Ød1	l1	t1	u1	o
A/F 601	100	160	110	130	3.5	9	28	62	31.3	8	76
	112	160	110	130	3.5	9	28	62	31.3	8	76
	132	200	130	165	3.5	11	38	82	41.3	10	101

~ Kg	
PAM B14	A/F 601
100	34.5
112	34.5
132	38

A 602 - 603

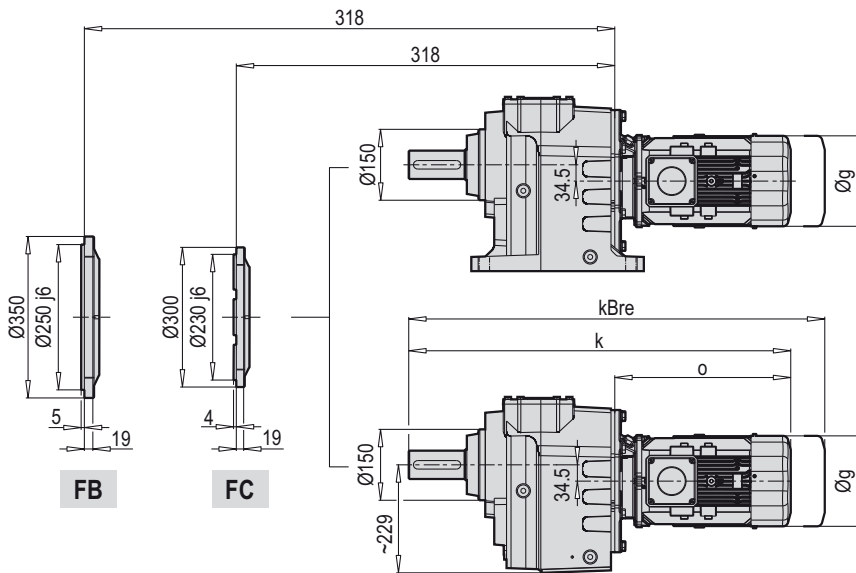
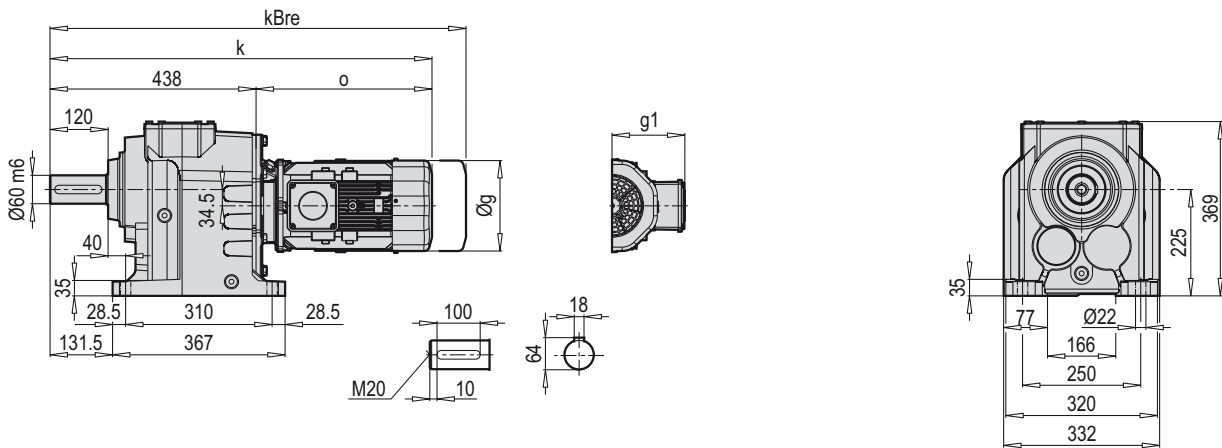

AF 602 - 603

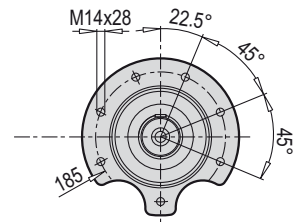

F 602 - 603

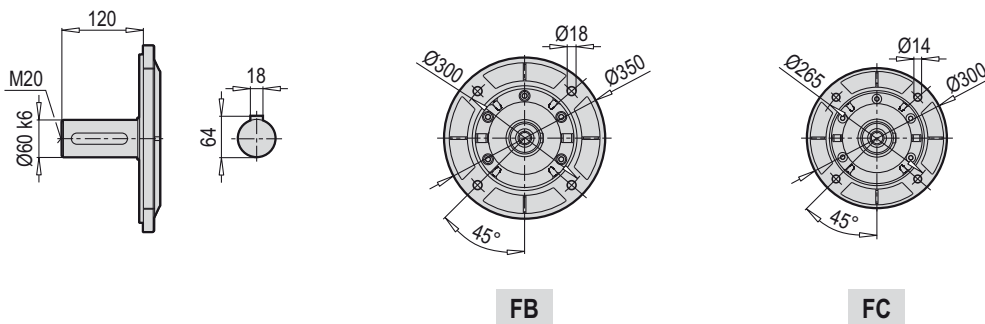

	90 S/L	100 L	112 M	132 S	132 M	160 M/L	180 M/L	
g	182	202	220	270.5	270.5	321.5	363	
g1	130	153	158.5	187.5	187.5	214	249	
k	757	811	809	882	882	963	1053	
kBre	825	894	909	982	1002	1068	1172	
o	319	373	371	444	444	525	615	

A 602-603 PAM B5/B14

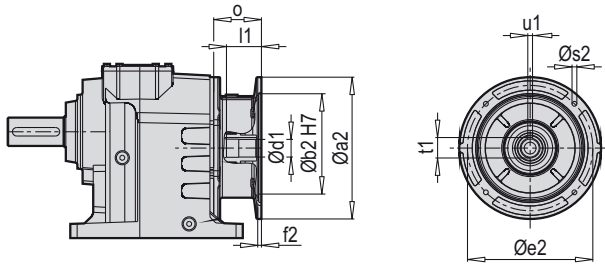

A 602-603 W

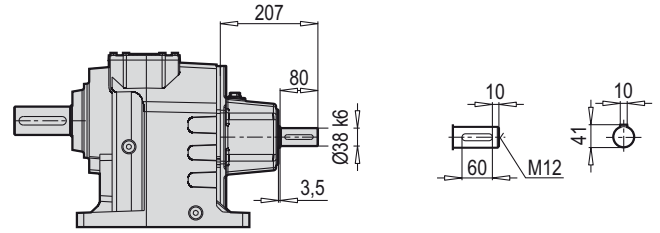

F 602-603 PAM B5/B14

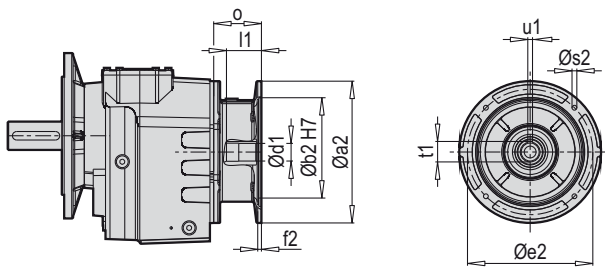

F 602-603 W

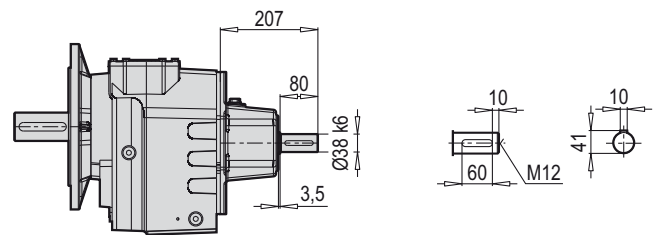

AF 602-603 PAM B5/B14

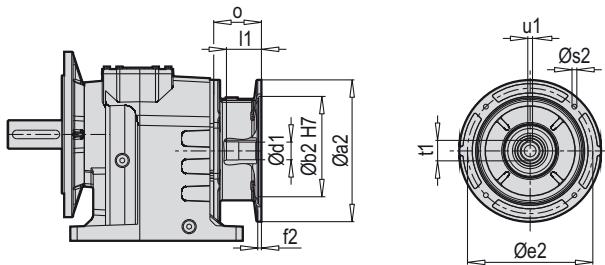

AF 602-603 W

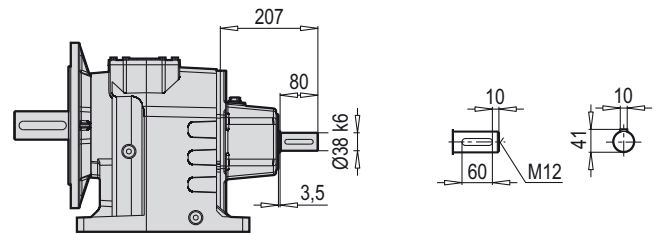

W ~ Kg	
A/F 602-603	90

Tip / Type Typ / Tipo Type / Tipo	PAM B5	Øa2	Øb2	Øe2	f2	Øs2	Ød1	l1	t1	u1	o
A/F 602 A/F 603	90	200	130	165	5	M10	24	52	27.3	8	61
	100	250	180	215	5.5	M12	28	62	31.3	8	76
	112	250	180	215	5.5	M12	28	62	31.3	8	76
	132	300	230	265	5.5	M12	38	82	41.3	10	101
	160	350	250	300	7	M16	42	112	45.3	12	148
	180	350	250	300	7	M16	48	112	51.8	14	148

~ Kg	
PAM B5	A/F 602-603
90	81
100	85
112	85
132	88
160	94
180	94

Tip / Type Typ / Tipo Type / Tipo	PAM B14	Øa2	Øb2	Øe2	f2	Øs2	Ød1	l1	t1	u1	o
A/F 602 A/F 603	90	140	95	115	3	9	24	52	27.3	8	61
	100	160	110	130	3.5	9	28	62	31.3	8	76
	112	160	110	130	3.5	9	28	62	31.3	8	76
	132	200	130	165	3.5	11	38	82	41.3	10	101

~ Kg	
PAM B14	A/F 602-603
90	78
100	80
112	80
132	86

A 701

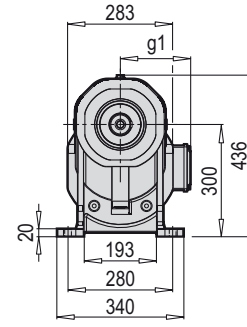
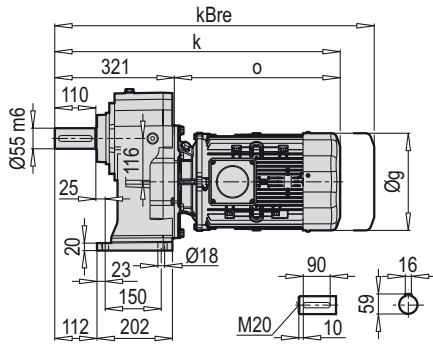

AF-M 701

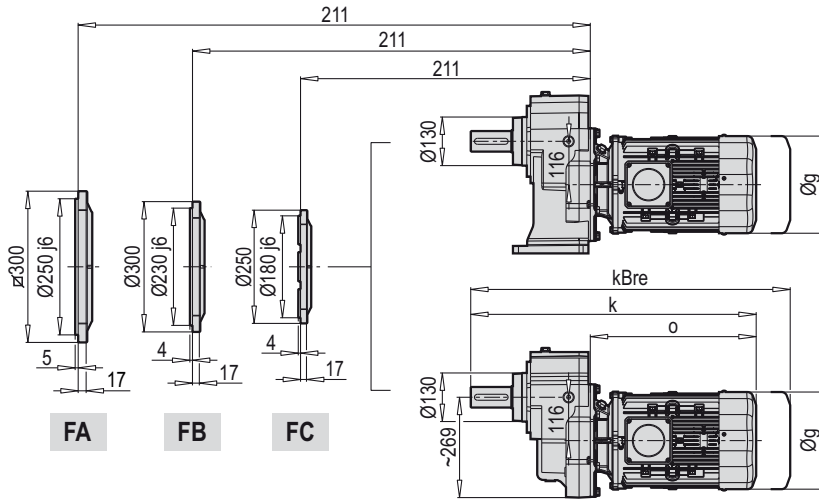
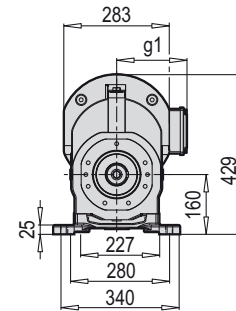
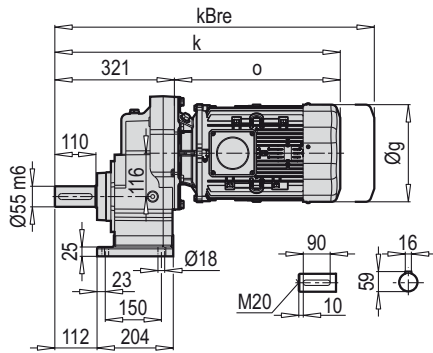

AF 701

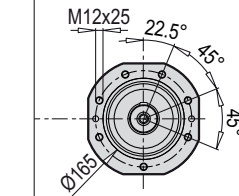

F 701

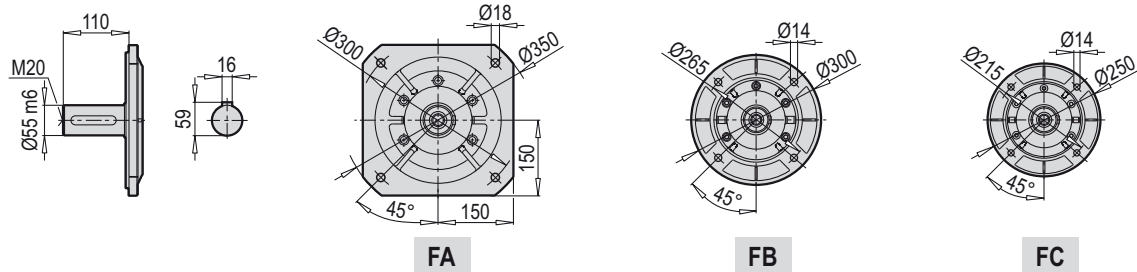

FA

FB

FC

	132 S	132 M	160 M/L	180 M/L	200 L			
g	270.5	270.5	321.5	363	363			
g1	187.5	187.5	214	249	249			
k	765	765	846	936	936			
kBre	865	885	951	1055	1055			
o	444	444	525	615	615			

A 701 PAM B5/B14

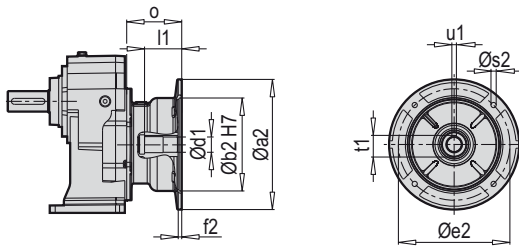

A 701 W

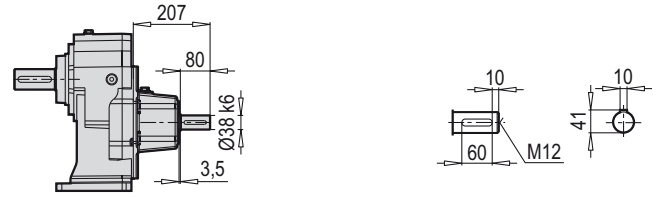

F 701 PAM B5/B14

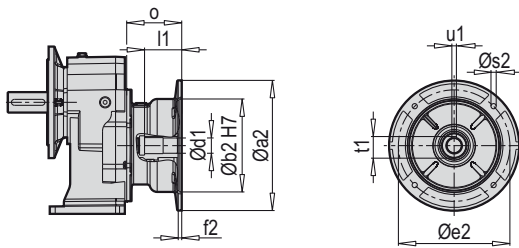

F 701 W

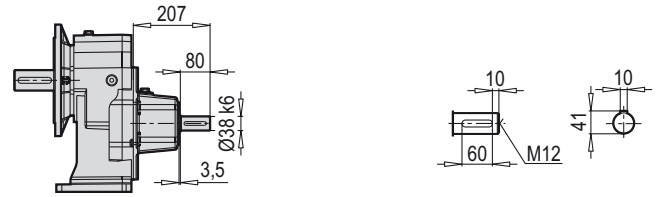

AF 701 PAM B5/B14

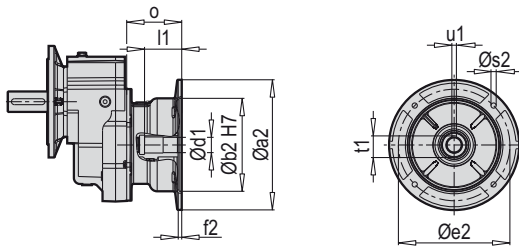

AF 701 W



AF-M 701 PAM B5/B14

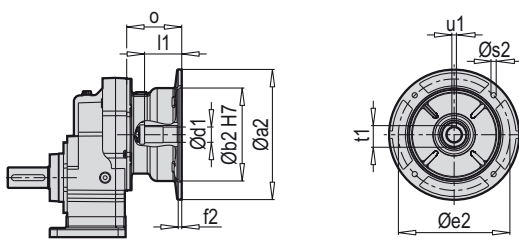

AF-M 701 W

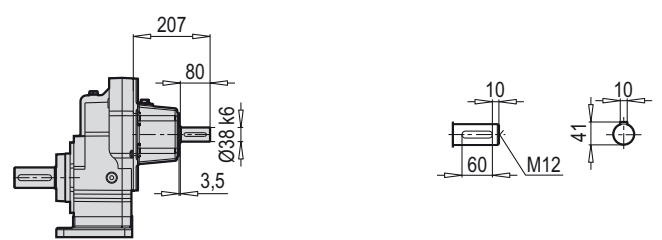

W ~ Kg	
A/F 701	49

Tip / Type Typ / Tipo Type / Tipo	PAM B5	Øa2	Øb2	Øe2	f2	Øs2	Ød1	l1	t1	u1	o
A/F 701	132	300	230	265	5.5	M12	38	82	41.3	10	101
	160	350	250	300	7	M16	42	112	45.3	12	148
	180	350	250	300	7	M16	48	112	51.8	14	148
	200	400	300	350	7	M16	55	112	59.3	16	185

~ Kg	
PAM B5	A/F 701
132	43
160	50
180	50
200	65

Tip / Type Typ / Tipo Type / Tipo	PAM B14	Øa2	Øb2	Øe2	f2	Øs2	Ød1	l1	t1	u1	o
A/F 701	132	200	130	165	3.5	11	38	82	41.3	10	101

~ Kg	
PAM B14	A/F 701
132	41

A 702 - 703

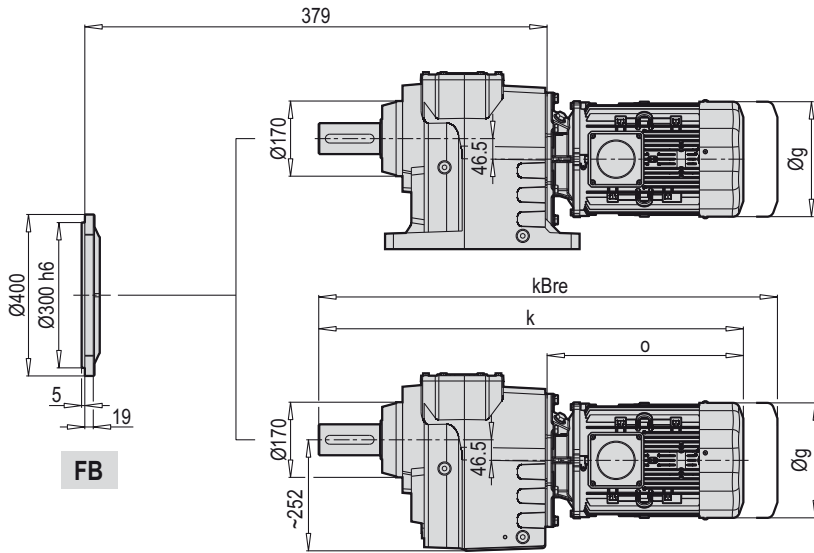
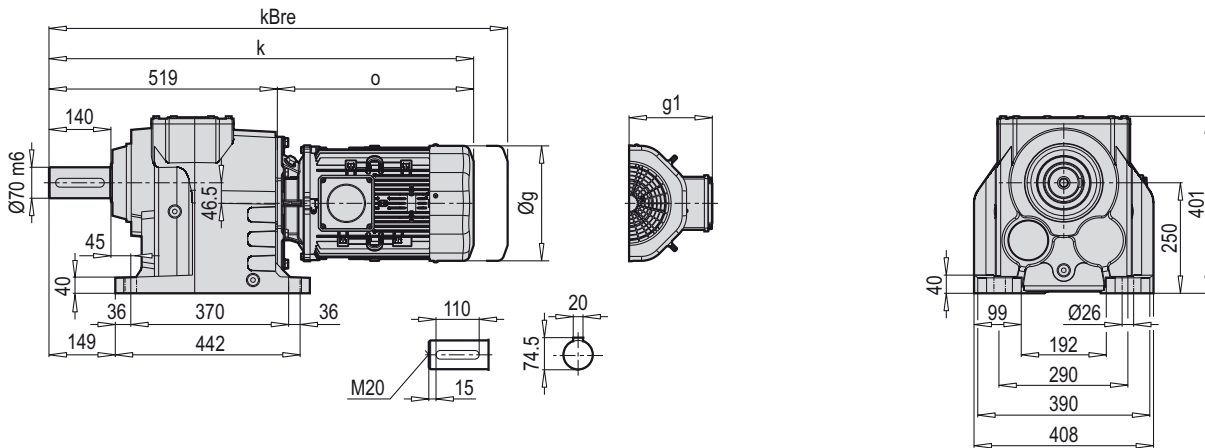

AF 702 - 703

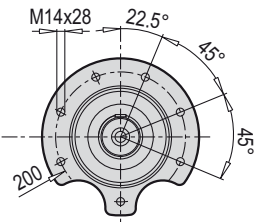

F 702 - 703

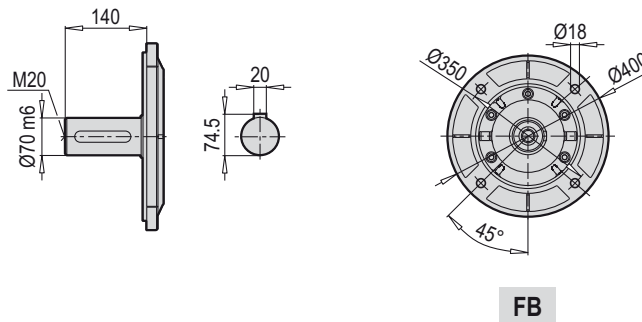

FB

	100 L	112 M	132 S	132 M	160 M/L	180 M/L	200 L	
g	202	220	270.5	270.5	321.5	363	363	
g1	153	158.5	187.5	187.5	214	249	249	
k	892	890	963	963	1044	1134	1134	
kBre	975	990	1063	1083	1149	1253	1253	
o	373	371	444	444	525	615	615	

A 702-703 PAM B5/B14

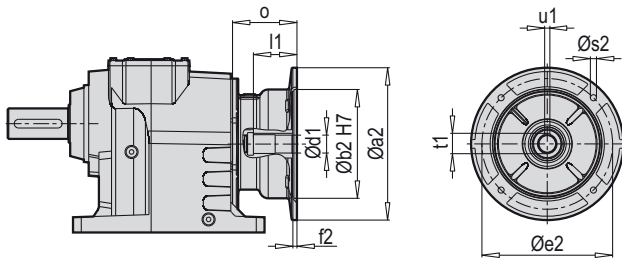

A 702-703 W

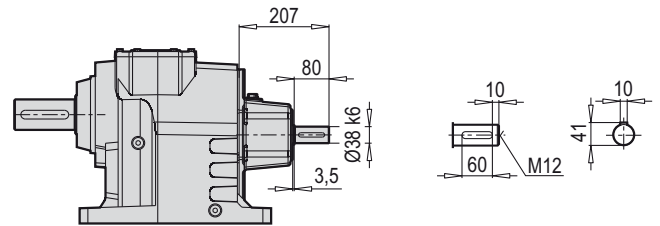

F 702-703 PAM B5/B14

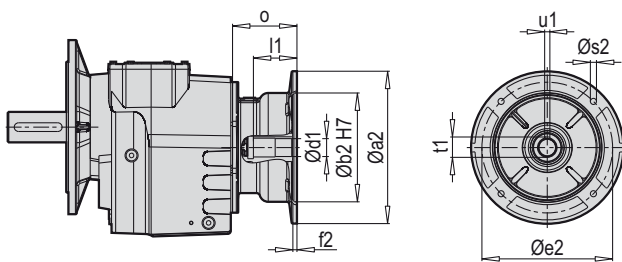

F 702-703 W

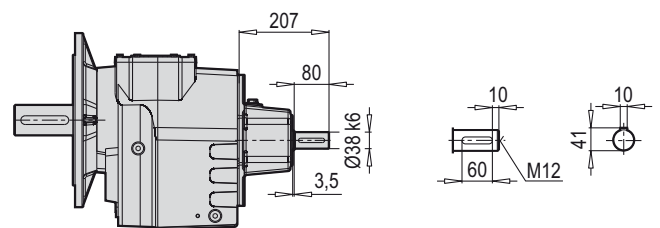

AF 702-703 PAM B5/B14

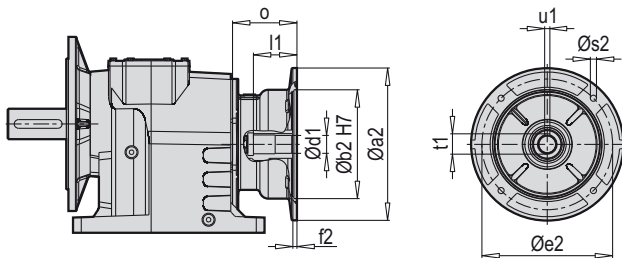

AF 702-703 W

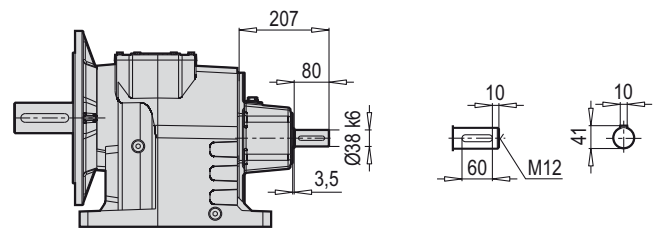

W ~ Kg	
A/F 702-703	119

Tip / Type Typ / Tipo Type / Tipo	PAM B5	Øa2	Øb2	Øe2	f2	Øs2	Ød1	l1	t1	u1	o
A/F 702 A/F 703	100	250	180	215	5.5	M12	28	62	31.3	8	76
	112	250	180	215	5.5	M12	28	62	31.3	8	76
	132	300	230	265	5.5	M12	38	82	41.3	10	101
	160	350	250	300	7	M16	42	112	45.3	12	148
	180	350	250	300	7	M16	48	112	51.8	14	148
	200	400	300	350	7	M16	55	112	59.3	16	185

~ Kg	
PAM B5	A/F 702-703
100	114
112	114
132	117
160	123
180	123
200	139

Tip / Type Typ / Tipo Type / Tipo	PAM B14	Øa2	Øb2	Øe2	f2	Øs2	Ød1	l1	t1	u1	o
A/F 702 A/F 703	100	160	110	130	3.5	9	28	62	31.3	8	76
	112	160	110	130	3.5	9	28	62	31.3	8	76
	132	200	130	165	3.5	11	38	82	41.3	10	101

~ Kg	
PAM B14	A/F 702-703
100	109
112	109
132	115

A 902 - 903

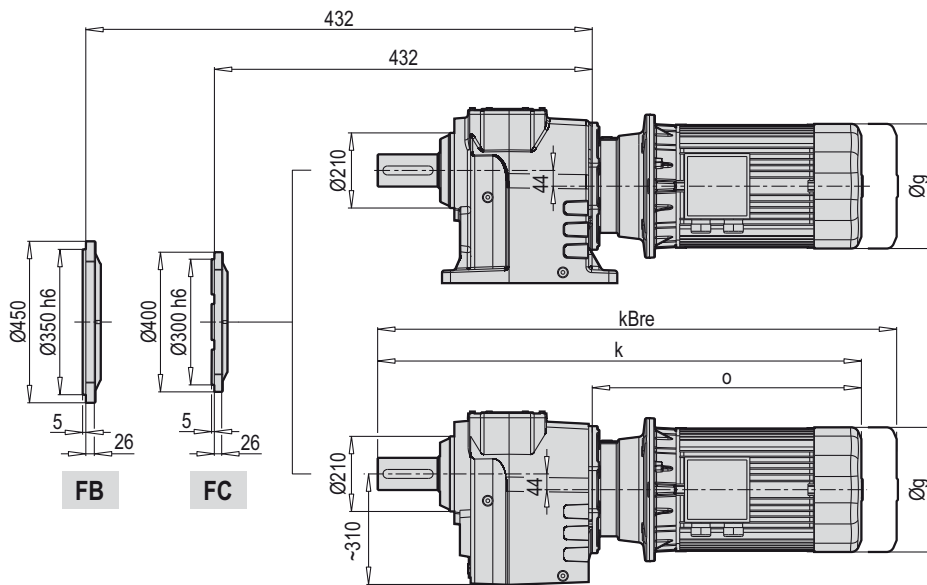
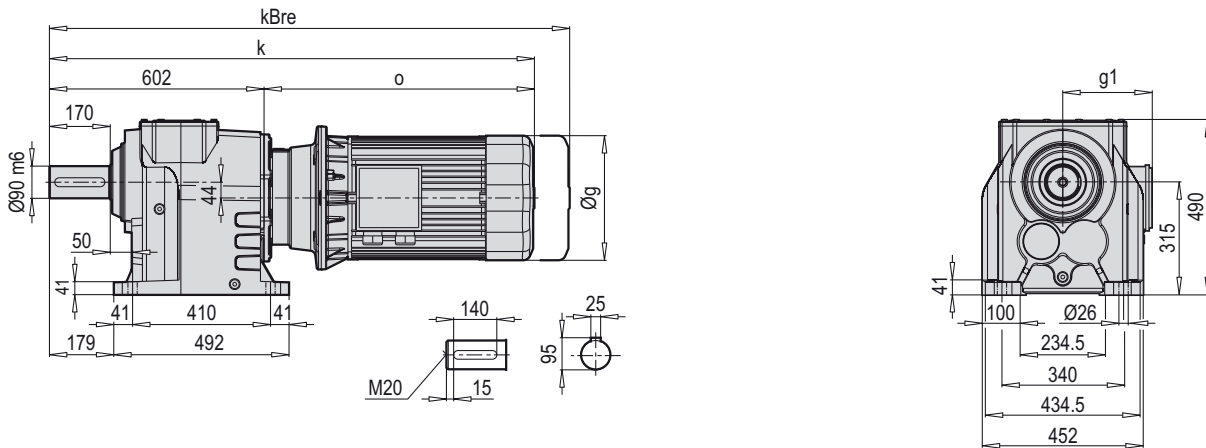

AF 902 - 903

F 902 - 903

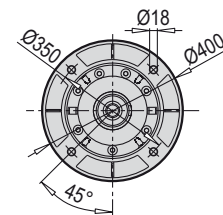
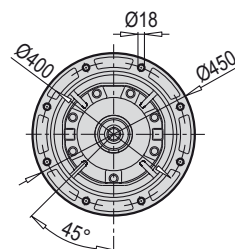
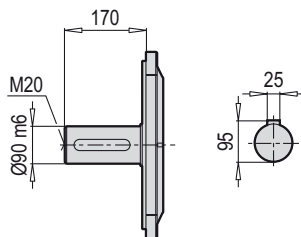
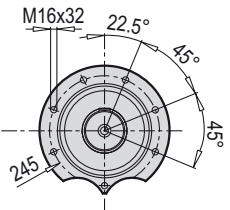

FB

FC

	132 S	132 M	160 M/L	180 M/L	200 L	225 M		
g	270.5	270.5	321.5	363	363	456		
g1	187.5	187.5	214	249	249	260		
k	1079	1079	1206	1311	1358	1388		
kBre	1179	1199	1311	1428	1474	1558		
o	477	477	604	709	756	786		

A 902-903 PAM B5/B14

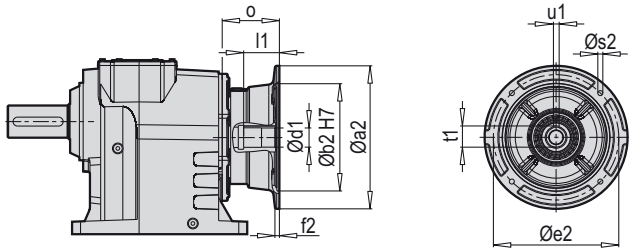

A 902-903 W

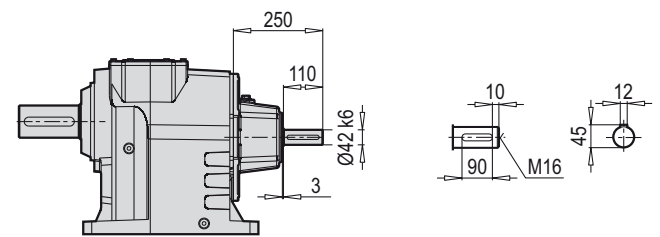

F 902-903 PAM B5/B14

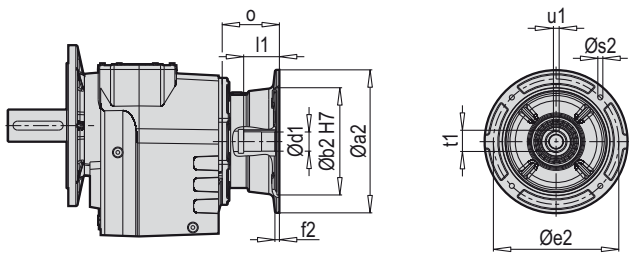

F 902-903 W

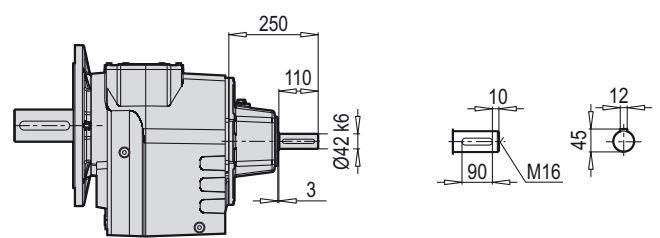

AF 902-903 PAM B5/B14

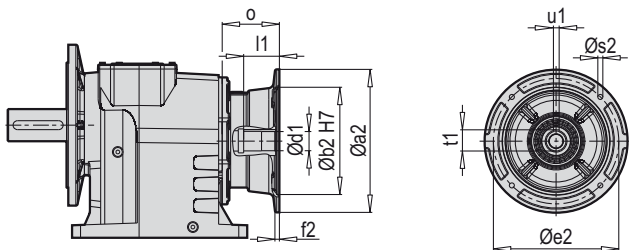

AF 902-903 W

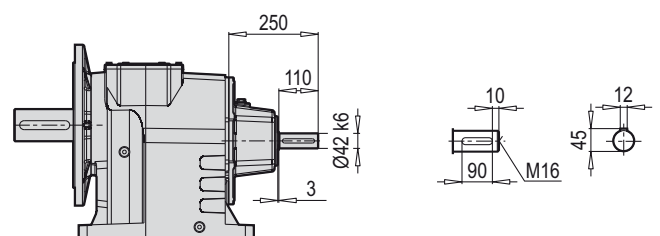

W ~ Kg	
A/F 902-903	195

Tip / Type Typ / Tipo Type / Tipo	PAM B5	Øa2	Øb2	Øe2	f2	Øs2	Ød1	l1	t1	u1	o
A/F 902 A/F 903	132	300	230	265	5.5	M12	38	82	41.3	10	76
	160	350	250	300	7	M16	42	112	45.3	12	124
	180	350	250	300	7	M16	48	112	51.8	14	124
	200	400	300	350	7	M16	55	112	59.3	16	161
	225	450	350	400	7	M16	60	142	64.4	18	161

~ Kg	
PAM B5	A/F 902-903
132	182
160	190
180	190
200	205
225	208

Tip / Type Typ / Tipo Type / Tipo	PAM B14	Øa2	Øb2	Øe2	f2	Øs2	Ød1	l1	t1	u1	o
A/F 903	132	200	130	165	3.5	11	38	82	41.3	10	76

~ Kg	
PAM B14	A/F 903
132	175



A large area of the page is filled with horizontal dotted lines, providing a template for writing or drawing.

W - PAM - IEC Adaptörü Seçim Tabloları

Selection Tables
of W - PAM - IEC Adapters

Auswahltable von
W - PAM - IEC Adapters

Tabella si Selezione di
W - PAM - IEC Adattatore

Tableau de Sélection du
W - PAM - IEC Adaptateur

Tabla de Selección de
W - PAM - IEC Adaptador

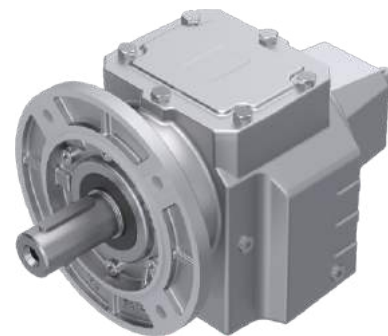
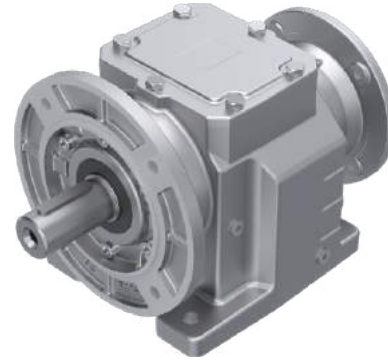
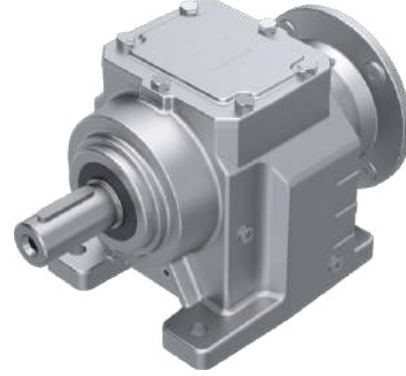

A/F

W ve IEC adaptörü için performans tablolarının yapısı

Notify about performance tables for W and IEC adapter type
Der Aufbau der Leistungstabellen für W - IEC und PAM-Adapter
Struttura delle tabelle delle prestazioni degli adattatori W - IEC e PAM
La structure de la table de performance pour W - Adaptateur IEC et PAM
Estructura de Tablas de Rendimiento para Adaptador de W - IEC ve PAM

A 253
F 253

Redüktör Tipi

Gear unit motor type
Getriebemotortyp
Tipo del motore con ingranaggi
Type du moteur à engrenages
Tipo del motor con engranaje

Max. Giriş Gücü

Max. Input Power
max. Antriebsleistung
Max. potenza di ingresso
Max. la puissance d'entrée
máx. potencia de entrada

Motor gövde büyüklüğü ile IEC gövde büyüklüğü aynı olan IEC montajlı redüktörler için Servis faktörü f_B motorlu seçim sayfalarından alınabilir.

Service factor f_B could be seen from selection of geared motor tables. Because this value is same for geared motor and geared motor with IEC adapters. Betriebsfaktor f_B kann aus den Motorauswahlseiten entnommen werden, da für die IEC montierten Getriebe die Motor Körpergröße und IEC Körpergröße die gleichen sind. Peri riduttori a montaggio IEC con grandezza del corpo motore uguale alla grandezza del corpo motore IEC il fattore di Servizio puo' essere rilevato dalle scelte di motori f_B . Facteur de service f_B peut être prise à partir de la page de sélection de moteur, pour réducteurs IEC montée dont moteur taille du corps et IEC taille du corps sont les mêmes. Factor de servicio para reductores con IEC montado, y con mismo tamaño de cuerpo de IEC y el cuerpo de motor, se puede encontrar en paginas de elección f_B motor.

Tip / Type Typ / Tipo Type / Tipo	i_{ges}	4-pol 50Hz 1400rpm n_2 [min ⁻¹]	M_{amax} $f_B=1$ 4 - pol. [Nm]	W			IEC - PAM							
				P_{1max} 4 - pol. 1400 rpm [kW]	FR1 [kN]	FR2 (a) [kN]	$f_B \Rightarrow$ 49 - 112							
A253	245.76	5.7	200	0.12	1.4	5.5	63*	71*						
F253	197.21	7.1	200	0.15	1.4	5.5	63*	71*						
	178.56	7.8	200	0.16	1.4	5.5	63*	71*						
	143.29	9.8	200	0.20	1.4	5.5	63	71*						
	123.58	11.3	200	0.24	1.3	5.5	63	71*	80*	90*				
	108.02	13.0	200	0.27	1.3	5.5	63	71*						
	100.12	14.0	200	0.29	1.3	5.5	63	71*	80*	90*				
	74.76	18.7	200	0.39	1.3	5.5	63	71	80*	90*				
	66.56	21.0	200	0.44	1.3	5.5	63	71	80*	90*				
	53.41	26.2	200	0.55	1.3	5.5	63	71	80*	90*				

Tahvil oranı
Reduction ratio
Verkleinerungsfaktor
Rapporto di riduzione
Rapport de réduction
Relación de de reducción

Çıkış devri
Output speed
Abtriebsdrehzahl
Velocità di uscita
Vitesse de sortie
Velocidad de salida

Çıkış momenti
Output torque
Abtriebsdrehmoment
Momento di uscita
Moment de sortie
Momento de salida

Tip W azami tahrik gücü hesaplanırken *italik* olmayan değerler alınmıştır.

P_{1max} ile $f_B = 1$
 P_{1max} value which is *non-italic* is calculated when service factor f_B is equal to one.
Bei der Berechnung der maximalen Antriebskraft von Typ W werden keine kursiv Werte übernommen. f_B mit $P_{1max} = 1$.
Nel calcolo della forza motrice massima tipo W sono stati presi valori non in corsivo. P_{1max} e $f_B = 1$
Bien que la force maximale de conduite de type W est calculé, les valeurs italiques ne sont pas prises. f_B avec $P_{1max} = 1$
Los valores no cursivos fueron tomados al calcular la fuerza motriz tipo W. P_{1max} con $f_B = 1$

IEC motor büyüklükleri ve IEC standart çıkışları DIN EN 50347'e göre.

According to DIN EN 50347 IEC motor sizes. IEC Motorgrößen und IEC-Standard-Ausgänge gemäß DIN EN 50347. Le grandezze dei motori IEC e le uscite standard IEC sono conformi a DIN EN 50347. Tailles de moteurs IEC et les sorties standards IEC est selon la norme DIN EN 50347. Tamaño de motores de IEC y salidas estandares de IEC son conformes a DIN EN 50347.

Rakamlı alanlar IEC adaptörünün, IEC motor büyüklüğü ve tahvil oranına uygun olduğunu belirtir.





This area which is colorless is shown IEC adapter is applicable for this IEC motor size and reduction ratio. Bedruckte Bereiche zeigen, dass der IEC - Adapter für die IEC Motorgröße und den Verkleinerungsfaktor anwendbar ist. Gli spazi con cifre degli adattatori IEC, indicano che la grandezza del motore IEC è conforme al rapporto di trasmissione. Zones numériques indiquent que l'adaptateur IEC est adapté pour IEC taille du moteur et taux de change. Áreas con números indican que es adaptador de IEC, es conforme a tamaño del motor IEC y al ratio de cambios.

Müsaade edilebilir max. radyal yükler (Çıkış)

Max. Permissible radial force (Output)
Zulässige max. radiale Kraft (Abtrieb)
Máx. Forza radiale ammessa (Uscita)
Max. Force radiale admissible (Sortie)
Max. Fuerza radial admissible (Salida)

Müsaade edilebilir max. radyal yükler (Giriş)

Max. Permissible radial force (Input)
Zulässige max. radiale Kraft (Antrieb)
Máx. Forza radiale ammessa (Entrada)
Max. Force radiale admissible (Entree)
Max. Fuerza radial admissible (Entrada)

Tip / Type Typ / Tipo Type / Tipo	i _{ges}	4-pol 50Hz 1400rpm n ₂ [min ⁻¹]	M _{amax} f _B =1 4 - pol. [Nm]	W			IEC - PAM							
				P _{1max} 4 - pol. 1400 rpm [kW]	FR1 [kN]	FR2 (a) [kN]	f _B ⇔  49 - 112							
A202	63.59	22.0	50	0.12	-	2.5	56	63*						
F202	55.03	25.4	50	0.13	-	2.5	56	63*						
W	49.05	28.5	46	0.14	-	2.5	56	63*						
	42.20	33.2	50	0.17	-	2.5	56	63*						
 115	36.45	38.4	54	0.22	-	2.5	56	63						
+	32.41	43.2	55	0.25	-	2.5	56	63						
PAM - IEC	26.38	53.1	54	0.29	-	2.5	56	63	71*					
	23.98	58.4	55	0.33	-	2.5	56	63	71*					
 115	21.90	63.9	55	0.36	-	2.5	56	63	71					
	21.36	65.5	55	0.38	-	2.5	56	63	71					
	19.23	72.8	55	0.42	-	2.5	56	63	71					
	17.37	80.6	55	0.46	-	2.5	56	63	71					
	15.75	88.9	55	0.51	-	2.5	56	63	71					
	14.42	97.1	51	0.52	-	2.5	56	63	71					
	13.23	105.8	47	0.52	-	2.5	56	63	71					
	11.52	121.5	50	0.55	-	2.5	56	63	71					
	10.03	139.6	55	0.55	-	2.5	56	63	71					
	8.93	156.8	55	0.55	-	2.5	56	63	71					
	8.03	174.3	55	0.55	-	2.5	56	63	71					
	7.21	194.2	55	0.55	-	2.5	56	63	71					
	6.55	213.7	53	0.55	-	2.5	56	63	71					
	5.98	234.1	55	0.55	-	2.5	56	63	71					
	5.49	255.0	55	0.55	-	2.5	56	63	71					
	5.33	262.7	55	0.55	-	2.5	56	63	71					
	4.79	292.3	53	0.55	-	2.5	56	63	71					
	4.29	326.3	50	0.55	-	2.5	56	63	71					
	3.90	359.0	45	0.55	-	2.5	56	63	71					
	3.56	393.3	48	0.55	-	2.5	56	63	71					
	3.26	429.4	47	0.55	-	2.5	56	63	71					
	2.97	471.4	46	0.55	-	2.5	56	63	71					
	2.83	494.7	45	0.55	-	2.5	56	63	71					
	2.55	549.0	41	0.55	-	2.5	56	63	71					
	2.31	606.1	39	0.55	-	2.5	56	63	71					
	2.12	660.4	36	0.55	-	2.5	56	63	71					

IEC - PAM bağlantısı yoktur / No IEC - PAM assembling on empty fields / Keine IEC - PAM-Verbindung / Nessun assemblaggio IEC - PAM su campi vuoti / Pas d'assemblage IEC - PAM sur champs vides / Sin montaje IEC - PAM en campos vacíos

63 IEC - PAM bağlantısı yapılır / IEC - PAM assembling available on numbered fields / IEC - PAM-Verbindung möglich / Montaggio IEC - PAM disponibile su campi numerati / Assemblage IEC - PAM disponible sur champs numérotés / Assemblage IEC - PAM disponible sur champs numérotés /









80* IEC - PAM bağlantısı yapılacaksa P_{1max} değerleri aşılmamalıdır / Do not exceed the P_{1max} values indicated on fields with asterisk / Bei IEC - PAM-Verbindungen, sollten die P_{1max}-Werte nicht überschritten werden / Non superare i valori P_{1max} indicati sui campi con l'asterisco / Ne pas dépasser les valeurs P_{1max} indiquées sur les champs avec astérisque / No exceda los valores de P_{1max} indicados en los campos con asterisco

Tip / Type Typ / Tipo Type / Tipo	i _{ges}	4-pol 50Hz 1400rpm n ₂ [min ⁻¹]	M _{amax} f _B =1 4 - pol. [Nm]	W			IEC - PAM							
				P _{1max} 4 - pol. 1400 rpm [kW]	FR1 [kN]	FR2 (a) [kN]	f _B ⇨ 49 - 112							
A 202 G	81.41	17.2	83	0.15	1.2	2.8	56	63*						
F 202 G	70.05	20.0	72	0.15	1.2	2.8	56	63*						
W	62.38	22.4	64	0.15	1.2	2.8	56	63*	71*					
	54.05	25.9	85	0.23	1.2	2.8	56	63	71*					
117	46.41	30.2	85	0.27	1.2	2.8	56	63	71*					
+	41.38	33.8	85	0.30	1.2	2.8	56	63	71*					
PAM - IEC	37.17	37.7	85	0.32	1.2	2.8	56	63	71*					
	34.00	41.2	86	0.36	1.2	2.8	56	63	71*					
117	30.55	45.8	92	0.43	1.2	2.8	56	63	71					
	27.66	50.6	92	0.49	1.2	2.8	56	63	71	80*				
	24.83	56.4	92	0.54	1.2	2.8	56	63	71	80*				
	22.44	62.4	92	0.60	1.2	2.8	56	63	71	80*				
	20.35	68.8	85	0.61	1.2	2.8	56	63	71	80*				
	18.63	75.1	84	0.66	1.2	2.8	56	63	71	80*				
	15.74	88.9	85	0.79	1.2	2.8	56	63	71	80				
	13.56	103.2	85	0.92	1.2	2.8	56	63	71	80				
	12.09	115.8	87	1.05	1.2	2.8	56	63	71	80				
	11.41	122.7	85	1.09	1.2	2.8	56	63	71	80	90*			
	10.85	129.0	86	1.16	1.2	2.8	56	63	71	80	90*			
	9.81	142.7	85	1.27	1.2	2.8	56	63	71	80	90*			
	8.75	160.0	88	1.47	1.2	2.8	56	63	71	80	90*			
	7.81	179.3	82	1.50	1.2	2.8	56	63	71	80	90			
	7.04	198.9	82	1.50	1.2	2.8	56	63	71	80	90			
	6.41	218.4	82	1.50	1.2	2.8	56	63	71	80	90			
	5.74	243.9	77	1.50	1.2	2.8	56	63	71	80	90			
	5.16	271.3	83	1.50	1.2	2.8	56	63	71	80	90			
	4.63	302.4	72	1.50	1.2	2.8	56	63	71	80	90			
	4.19	334.1	65	1.50	1.2	2.8	56	63	71	80	90			
	3.81	367.5	59	1.50	1.2	2.8	56	63	71	80	90			
	3.44	407.0	54	1.50	1.2	2.8	56	63	71	80	90			
	3.24	432.1	54	1.50	1.2	2.8	56	63	71	80	90			
	2.95	474.6	50	1.50	1.2	2.8	56	63	71	80	90			
	2.74	510.9	46	1.50	1.2	2.8	56	63	71	80	90			
	2.51	557.8	43	1.50	1.2	2.8	56	63	71	80	90			
	2.31	606.1	43	1.50	1.2	2.8	56	63	71	80	90			

IEC - PAM bağlantısı yoktur / No IEC - PAM assembling on empty fields / Keine IEC - PAM-Verbindung / Nessun assemblaggio IEC - PAM su campi vuoti / Pas d'assemblage IEC - PAM sur champs vides / Sin montaje IEC - PAM en campos vacíos

63 IEC - PAM bağlantısı yapılır / IEC - PAM assembling available on numbered fields / IEC - PAM-Verbindung möglich / Montaggio IEC - PAM disponibile sui campi numerati / Assemblage IEC - PAM disponible sur champs numérotés / Assemblage IEC - PAM disponible sur champs numérotés /

80* IEC - PAM bağlantısı yapılacaksa P_{1max} değerleri aşılmamalıdır / Do not exceed the P_{1max} values indicated on fields with asterisk / Bei IEC - PAM-Verbindungen, sollten die P_{1max}-Werte nicht überschritten werden / Non superare i valori P_{1max} indicati sui campi con l'asterisco / Ne pas dépasser les valeurs P_{1max} indiquées sur les champs avec astérisque / No exceda los valores de P_{1max} indicados en los campos con asterisco

Tip / Type Typ / Tipo Type / Tipo	i _{ges}	4-pol 50Hz 1400rpm n ₂ [min ⁻¹]	M _{amax} f _B =1 4 - pol. [Nm]	W			IEC - PAM							
				P _{1max} 4 - pol. 1400 rpm [kW]	FR1 [kN]	FR2 (a) [kN]	f _B ⇔  49 - 112							
A253	245.76	5.7	200	0.12	1.4	5.5	63*	71*						
F253	197.21	7.1	200	0.15	1.4	5.5	63*	71*						
W	178.56	7.8	200	0.16	1.4	5.5	63*	71*						
	143.29	9.8	200	0.20	1.4	5.5	63	71*						
 119	123.58	11.3	200	0.24	1.3	5.5	63	71*	80*	90*				
+	108.02	13.0	200	0.27	1.3	5.5	63	71*						
PAM - IEC	99.17	14.1	200	0.30	1.3	5.5	63	71*	80*	90*				
	74.76	18.7	200	0.39	1.3	5.5	63	71	80*	90*				
 119	66.56	21.0	200	0.44	1.3	5.5	63	71	80*	90*				
	53.41	26.2	200	0.55	1.3	5.5	63	71	80*	90*				
A252	47.93	29.2	200	0.61	1.3	5.5	71	80*	90*					
F252	42.00	33.3	200	0.70	1.2	5.5	71	80*	90*					
W	38.46	36.4	200	0.76	1.2	5.5	71	80	90*					
	33.38	41.9	200	0.88	1.2	5.5	71	80	90*					
 119	30.15	46.4	200	0.97	1.2	5.3	71	80	90*					
+	26.79	52.3	200	1.09	1.1	5.0	71	80	90*					
PAM - IEC	24.19	57.9	200	1.21	1.1	4.8	71	80	90*					
	23.04	60.8	200	1.27	1.1	4.7	71	80	90*	100*	112*			
 119	20.19	69.3	200	1.45	1.1	4.4	71	80	90*					
	18.49	75.7	200	1.59	1.0	4.2	71	80	90	100*	112*			
	17.05	82.1	190	1.63	1.0	4.1	71	80	90	100*	112*			
	14.91	93.9	170	1.67	1.0	4.1	71	80	90	100*	112*			
	13.94	100.4	170	1.79	1.0	3.9	71	80	90	100*	112*			
	11.97	117.0	145	1.78	1.0	3.9	71	80	90	100*	112*			
	10.32	135.7	140	1.99	0.9	3.7	71	80	90	100*	112*			
	9.02	155.2	130	2.11	0.9	3.6	71	80	90	100*	112*			
	7.93	176.5	125	2.31	0.8	3.4	71	80	90	100*	112*			
	6.36	220.0	105	2.42	0.8	3.3	71	80	90	100*	112*			
	4.80	291.8	95	2.90	0.7	3.0	71	80	90	100*	112*			

IEC - PAM bağlantısı yoktur / No IEC - PAM assembling on empty fields / Keine IEC - PAM-Verbindung / Nessun assemblaggio IEC - PAM su campi vuoti / Pas d'assemblage IEC - PAM sur champs vides / Sin montaje IEC - PAM en campos vacíos

63 **IEC - PAM bağlantısı yapılır** / IEC - PAM assembling available on numbered fields / IEC - PAM-Verbindung möglich / Montaggio IEC - PAM disponibile sui campi numerati / Assemblage IEC - PAM disponible sur champs numérotés / Assemblage IEC - PAM disponible sur champs numérotés /













80* **IEC - PAM bağlantısı yapılacaksa P_{1max} değerleri aşılmamalıdır** / Do not exceed the P_{1max} values indicated on fields with asterisk / Bei IEC - PAM-Verbindungen, sollten die P_{1max}-Werte nicht überschritten werden / Non superare i valori P_{1max} indicati sui campi con l'asterisco / Ne pas dépasser les valeurs P_{1max} indiquées sur les champs avec astérisque / No exceda los valores de P_{1max} indicados en los campos con asterisco

Tip / Type Typ / Tipo Type / Tipo	i _{ges}	4-pol 50Hz 1400rpm n ₂ [min ⁻¹]	M _{amax} f _B =1 4 - pol. [Nm]	W			IEC - PAM							
				P _{1max} 4 - pol. 1400 rpm [kW]	FR1 [kN]	FR2 (a) [kN]	f _B ⇔ 49 - 112							
A303	282.17	5.0	300	0.16	1.4	6.6	63*	71*						
F303	227.56	6.2	300	0.19	1.4	6.6	63	71*						
W	205.01	6.8	300	0.21	1.4	6.6	63	71*						
	165.33	8.5	300	0.27	1.4	6.6	63	71*						
123	141.89	9.9	300	0.31	1.4	6.6	63	71*	80*	90*				
+	125.65	11.1	300	0.35	1.3	6.6	63	71*						
PAM - IEC	114.42	12.2	300	0.38	1.3	6.6	63	71	80*	90*				
	86.96	16.1	300	0.51	1.3	6.6	63	71	80*	90*				
123	76.42	18.3	300	0.58	1.3	6.6	63	71	80*	90*				
	61.63	22.7	300	0.71	1.3	6.6	63	71	80*	90*				
A302	55.03	25.4	280	0.75	1.3	6.6	71	80	90*					
F302	48.22	29.0	280	0.85	1.2	6.6	71	80	90*					
W	44.38	31.5	280	0.93	1.2	6.6	71	80	90*					
	38.33	36.5	280	1.07	1.2	6.6	71	80	90*					
123	34.62	40.4	280	1.19	1.2	6.6	71	80	90*					
+	30.91	45.3	280	1.33	1.1	6.6	71	80	90*					
PAM - IEC	27.92	50.1	280	1.47	1.1	6.6	71	80	90*					
	26.45	52.9	260	1.44	1.1	6.6	71	80	90*	100*	112*			
123	23.49	59.6	260	1.62	1.0	6.3	71	80	90					
	21.33	65.6	250	1.72	1.0	6.1	71	80	90	100*	112*			
	19.29	72.6	250	1.90	1.0	5.8	71	80	90	100*	112*			
	16.21	86.3	250	2.26	0.9	5.4	71	80	90	100*	112*			
	13.81	101.4	250	2.65	0.8	5.0	71	80	90	100*	112*			
	12.00	116.7	250	3.05	0.7	4.7	71	80	90	100	112*			
	10.50	133.4	240	3.35	0.6	4.5	71	80	90	100	112*			
	9.11	153.7	210	3.38	0.6	4.4	71	80	90	100	112*			
	7.34	190.6	160	3.19	0.7	4.4	71	80	90	100	112*			
	5.58	250.8	160	4.20	0.4	3.9	71	80	90	100	112*			
A301	8.88	157.7	55	0.91	1.2	1.0	71	80	90*					
F301	7.78	180.0	50	0.94	1.2	1.0	71	80	90*					
W	6.18	226.5	50	1.19	1.2	0.9	71	80	90*					
	5.58	250.7	50	1.31	1.2	0.9	71	80	90*					
121	5.08	275.8	45	1.30	1.2	0.9	71	80	90*					
+	4.27	328.1	45	1.55	1.1	0.8	71	80	90					
PAM - IEC	3.65	383.9	45	1.81	1.1	0.8	71	80	90					
	3.16	443.3	40	1.86	1.1	0.7	71	80	90					
121	2.76	506.9	30	1.59	1.1	0.7	71	80	90					
	2.59	540.4	30	1.70	1.1	0.7		80	90					
	2.04	686.8	25	1.80	1.1	0.7		80	90					
	1.47	953.2	25	2.50	1.0	0.6	71	80	90					

IEC - PAM bağlantısı yoktur / No IEC - PAM assembling on empty fields / Keine IEC - PAM-Verbindung / Nessun assemblaggio IEC - PAM su campi vuoti / Pas d'assemblage IEC - PAM sur champs vides / Sin montaje IEC - PAM en campos vacíos

63 **IEC - PAM bağlantısı yapılır / IEC - PAM assembling available on numbered fields / IEC - PAM-Verbindung möglich / Montaggio IEC - PAM disponibile su campi numerati / Assemblage IEC - PAM disponible sur champs numérotés / Assemblage IEC - PAM disponible sur champs numérotés /**

80* **IEC - PAM bağlantısı yapılacaksa P_{1max} değerleri aşılmamalıdır / Do not exceed the P_{1max} values indicated on fields with asterisk / Bei IEC - PAM-Verbindungen, sollten die P_{1max}-Werte nicht überschritten werden / Non superare i valori P_{1max} indicati sui campi con l'asterisco / Ne pas dépasser les valeurs P_{1max} indiquées sur les champs avec astérisque / No exceda los valores de P_{1max} indicados en los campos con asterisco**

Tip / Type Typ / Tipo Type / Tipo	i _{ges}	4-pol 50Hz 1400rpm n ₂ [min ⁻¹]	M _{amax} f _B =1 4 - pol. [Nm]	W			IEC - PAM							
				P _{1max} 4 - pol. 1400 rpm [kW]	FR1 [kN]	FR2 (a) [kN]	f _B ⇔  49 - 112							
A353	268.00	5.2	500	0.27	1.4	8.0	63	71*						
F353	216.67	6.5	500	0.34	1.3	8.0	63	71*						
W	194.72	7.2	500	0.38	1.3	8.0	63	71						
	157.42	8.9	500	0.47	1.3	8.0	63	71						
 127	134.76	10.4	500	0.54	1.3	8.0	63	71	80*	90*				
+	108.95	12.9	500	0.67	1.3	8.0	63	71	80*	90*				
PAM - IEC	90.51	15.5	500	0.81	1.3	8.0	63	71	80	90*				
	72.58	19.3	500	1.01	1.2	8.0	63	71	80	90*				
 127	58.68	23.9	500	1.25	1.2	8.0	63	71	80	90*				
A352	56.95	24.6	490	1.26	1.2	8.0	71	80	90*					
F352	49.88	28.1	490	1.44	1.1	8.0	71	80	90*					
W	46.04	30.4	490	1.56	1.1	8.0	71	80	90					
	39.59	35.4	490	1.81	1.1	8.0	71	80	90	100*	112*			
 127	33.50	41.8	490	2.14	1.0	8.0	71	80	90					
+	32.01	43.7	490	2.24	1.0	8.0	71	80	90	100*	112*			
PAM - IEC	28.89	48.5	490	2.49	1.0	7.9	71	80	90	100*	112*			
	26.59	52.6	490	2.70	0.9	7.6	71	80	90	100*	112*			
 127	25.13	55.7	470	2.74	0.9	7.5	71	80	90	100*	112*			
	22.03	63.6	470	3.13	0.9	7.1	71	80	90	100	112*			
	20.31	68.9	460	3.32	0.8	6.9	71	80	90	100	112*			
	18.30	76.5	460	3.68	0.8	6.5	71	80	90	100	112*			
	16.88	83.0	450	3.91	0.7	6.3	71	80	90	100	112*			
	14.52	96.4	430	4.34	0.6	6.0		80	90	100	112*			
	11.74	119.3	390	4.87	0.6	5.7		80	90	100	112			
	9.75	143.6	370	5.56	0.4	5.3		80	90	100	112			
	8.73	160.4	340	5.71	0.4	5.2		80	90	100	112			
	7.06	198.4	290	6.02	0.3	5.1		80	90	100	112			
	5.86	238.8	260	6.50	0.3	4.8		80	90	100	112			
A351	8.50	164.7	100	1.72	1.2	2.5	71	80	90					
F351	7.44	188.1	100	1.97	1.1	2.5	71	80	90					
W	5.91	236.9	100	2.48	1.1	2.3	71	80	90	100*	112*			
	5.33	262.5	100	2.75	1.0	2.2	71	80	90	100*	112*			
 125	4.85	288.9	95	2.87	1.0	2.2	71	80	90	100*	112*			
+	4.07	344.3	90	3.24	1.0	2.0	71	80	90	100	112*			
PAM - IEC	3.75	373.3	90	3.52	1.0	2.0	71	80	90	100	112*			
	3.22	434.5	80	3.64	0.9	1.9		80	90	100	112*			
 125	2.62	534.5	70	3.92	0.9	1.8				100	112*			
	2.17	646.2	60	4.06	0.9	1.7		80	90	100	112*			
	1.45	964.4	60	6.06	0.6	1.5		80	90	100	112			
	1.30	1074.4	40	4.50	0.8	1.5		80	90	100	112			

IEC - PAM bağlantısı yoktur / No IEC - PAM assembling on empty fields / Keine IEC - PAM-Verbindung / Nessun assemblaggio IEC - PAM su campi vuoti / Pas d'assemblage IEC - PAM sur champs vides / Sin montaje IEC - PAM en campos vacíos

63 **IEC - PAM bağlantısı yapılır / IEC - PAM assembling available on numbered fields / IEC - PAM-Verbindung möglich / Montaggio IEC - PAM disponibile su campi numerati / Assemblage IEC - PAM disponible sur champs numérotés / Assemblage IEC - PAM disponible sur champs numérotés /**

























80* **IEC - PAM bağlantısı yapılacaksa P_{1max} değerleri aşılmamalıdır / Do not exceed the P_{1max} values indicated on fields with asterisk / Bei IEC - PAM-Verbindungen, sollten die P_{1max}-Werte nicht überschritten werden / Non superare i valori P_{1max} indicati sui campi con l'asterisco / Ne pas dépasser les valeurs P_{1max} indiquées sur les champs avec astérisque / No exceda los valores de P_{1max} indicados en los campos con asterisco**

Tip / Type Typ / Tipo Type / Tipo	i _{ges}	4-pol 50Hz 1400rpm n ₂ [min ⁻¹]	M _{amax} f _B =1 4 - pol. [Nm]	W			IEC - PAM								
				P _{1max} 4 - pol. 1400 rpm [kW]	FR1 [kN]	FR2 (a) [kN]	f _B ⇔ 49 - 112								
A403 F403 W 186.14 131 + PAM - IEC 118.13 131	267.75	5.2	850	0.47	2.8	12.0	71	80*	90*						
	234.50	6.0	850	0.53	2.8	12.0	71	80*	90*						
	215.01	6.5	850	0.58	2.8	12.0	71	80*	90*						
	186.14	7.5	850	0.67	2.7	12.0	71	80*	90*	100*	112*				
	170.55	8.2	850	0.73	2.7	12.0	71	80*	90*						
	149.47	9.4	850	0.83	2.7	12.0	71	80	90*	100*	112*				
	135.37	10.3	850	0.92	2.7	12.0	71	80	90*	100*	112*				
	118.13	11.9	850	1.05	2.7	12.0	71	80	90*	100*	112*				
	94.86	14.8	850	1.31	2.7	12.0	71	80	90*	100*	112*				
	85.91	16.3	850	1.45	2.6	12.0	71	80	90*	100*	112*				
	68.25	20.5	850	1.83	2.6	12.0		80	90	100*	112*				
	54.81	25.5	850	2.27	2.5	12.0		80	90	100*	112*				
	49.64	28.2	850	2.51	2.5	12.0		80	90	100*	112*				
	A402 F402 W 31.50 131 + PAM - IEC 19.94 131	45.38	30.9	850	2.75	2.4	12.0	80	90	100*	112*				
39.72		35.2	850	3.14	2.4	12.0	80	90	100	112*					
36.44		38.4	800	3.22	2.4	12.0	80	90	100	112*					
31.50		44.4	850	3.96	2.3	12.0	80	90	100	112*	132*				
28.89		48.5	800	4.06	2.3	12.0	80	90	100	112*					
25.30		55.3	850	4.93	2.1	12.0	80	90	100	112	132*				
22.91		61.1	850	5.44	2.1	12.0	80	90	100	112	132*				
19.94		70.2	850	6.25	1.9	11.7	80	90	100	112	132*				
17.37		80.6	830	7.00	1.8	11.1	80	90	100	112	132*				
16.01		87.4	800	7.33	1.8	10.8	80	90	100	112	132*				
14.50		96.6	700	7.08	1.8	10.9	80	90	100	112	132*				
12.44		112.5	700	8.25	1.7	10.2			100	112	132*				
11.46		122.2	650	8.32	1.7	10.1	80	90	100	112	132*				
9.20		152.2	600	9.56	1.5	9.4	80	90	100	112	132				
8.33		168.0	600	10.55	1.3	9.0	80	90	100	112	132				
7.22		193.9	550	11.17	1.3	8.7	80	90	100	112	132				
5.80		241.5	550	13.91	0.9	7.9	80	90	100	112	132				
5.25	266.7	500	13.96	0.9	7.8	80	90	100	112	132					
A401 F401 W 5.17 129 + PAM - IEC 3.11 129	8.25	169.7	170	3.02	2.7	3.7	80	90	100	112*					
	7.22	193.8	170	3.45	2.6	3.7	80	90	100	112*					
	5.73	244.4	170	4.35	2.5	3.4	80	90	100	112*					
	5.17	271.0	170	4.82	2.5	3.2	80	90	100	112					
	4.69	298.4	160	5.00	2.5	3.1	80	90	100	112					
	3.93	355.9	150	5.59	2.4	3.0	80	90	100	112					
	3.63	386.2	150	6.07	2.4	2.9	80	90	100	112					
	3.11	450.0	130	6.13	2.4	2.8			100	112					
	2.52	554.7	120	6.97	2.3	2.6	80	90	100	112					
	2.08	672.0	120	8.44	2.1	2.4	80	90	100	112					
1.31	1066.7	80	8.94	2.1	2.2	80	90	100	112						

IEC - PAM bağlantısı yoktur / No IEC - PAM assembling on empty fields / Keine IEC - PAM-Verbindung / Nessun assemblaggio IEC - PAM su campi vuoti / Pas d'assemblage IEC - PAM sur champs vides / Sin montaje IEC - PAM en campos vacíos

63 IEC - PAM bağlantısı yapılır / IEC - PAM assembling available on numbered fields / IEC - PAM-Verbindung möglich / Montaggio IEC - PAM disponibile su campi numerati / Assemblage IEC - PAM disponible sur champs numérotés / Assemblage IEC - PAM disponible sur champs numérotés /

80* IEC - PAM bağlantısı yapılacaksa P_{1max} değerleri aşılmamalıdır / Do not exceed the P_{1max} values indicated on fields with asterisk / Bei IEC - PAM-Verbindungen, sollten die P_{1max}-Werte nicht überschritten werden / Non superare i valori P_{1max} indicati sui campi con l'asterisco / Ne pas dépasser les valeurs P_{1max} indiquées sur les champs avec astérisque / No exceda los valores de P_{1max} indicados en los campos con asterisco

Tip / Type Typ / Tipo Type / Tipo	i _{ges}	4-pol 50Hz 1400rpm n ₂ [min ⁻¹]	M _{amax} f _B =1 4 - pol. [Nm]	W			IEC - PAM								
				P _{1max} 4 - pol. 1400 rpm [kW]	FR1 [kN]	FR2 (a) [kN]	f _B ⇔  49 - 112								
A503 F503 W   135 + PAM - IEC   135	222.59	6.3	1800	1.19	2.9	18.0	80	90*							
	194.86	7.2	1800	1.35	2.9	18.0	80	90*							
	178.98	7.8	1800	1.47	2.8	18.0	80	90*							
		162.21	8.6	1800	1.63	2.8	18.0	80	90						
	 135	154.52	9.1	1800	1.71	2.8	18.0	80	90	100*	112*	132*			
		142.00	9.9	1800	1.86	2.8	18.0	80	90	100*	112*				
	+ PAM - IEC	124.25	11.3	1800	2.12	2.8	18.0	80	90	100*	112*	132*			
		112.61	12.4	1800	2.34	2.7	18.0	80	90	100*	112*	132*			
	 135	97.80	14.3	1800	2.70	2.7	18.0	80	90	100*	112*	132*			
		85.33	16.4	1800	3.09	2.7	18.0	80	90	100	112*	132*			
		78.64	17.8	1800	3.36	2.6	18.0	80	90	100	112*	132*			
		71.27	19.6	1800	3.70	2.6	18.0	80	90	100	112*	132*			
		56.21	24.9	1600	4.17	2.5	18.0	80	90	100	112*	132*			
	A502 F502 W   135 + PAM - IEC   135	48.77	28.7	1600	4.81	2.4	18.0	80	90	100	112	132*			
		43.32	32.3	1600	5.41	2.4	18.0	80	90	100	112	132*			
39.21		35.7	1600	5.98	2.3	17.7	80	90	100	112	132*				
		34.83	40.2	1600	6.73	2.2	16.7	80	90	100	112	132*			
 135		31.57	44.3	1600	7.43	2.1	16.0	80	90	100	112	132*			
		28.26	49.5	1600	8.30	2.0	15.1	80	90	100	112	132*			
+ PAM - IEC		26.98	51.9	1600	8.69	2.0	14.8			100	112	132*	160*		
		23.14	60.5	1600	10.14	1.8	13.7			100	112	132	160*		
 135		21.69	64.5	1600	10.81	1.7	13.2			100	112	132	160*		
		19.66	71.2	1600	11.93	1.6	12.6			100	112	132	160*		
		18.81	74.4	1500	11.69	1.6	12.7			100	112	132	160*		
		16.86	83.0	1500	13.04	1.5	12.1			100	112	132	160*		
		15.13	92.6	1500	14.54	1.3	11.4			100	112	132	160*		
		13.71	102.1	1400	14.97	1.3	11.3			100	112	132	160*		
		11.20	125.0	1100	14.39	1.3	11.5					132	160*		
		9.01	155.4	900	14.65	1.3	11.2					132	160*		
		8.16	171.5	800	14.36	1.3	11.2					132	160*		
	7.55	185.5	800	15.54	1.2	10.8					132	160			
	6.07	230.6	700	16.91	1.0	10.3					132	160			
	5.50	254.5	700	18.65	0.8	9.8					132	160			
A501 F501 W   133 + PAM - IEC   133	8.56	163.6	350	6.00	2.5	4.0	80	90	100	112	132*				
	7.60	184.2	350	6.75	2.4	4.0	80	90	100	112	132*				
	6.17	227.0	340	8.08	2.3	3.9	80	90	100	112	132*				
		5.62	249.3	330	8.62	2.2	3.7	80	90	100	112	132*			
	 133	4.73	295.8	320	9.91	2.1	3.5			100	112	132			
		4.06	344.9	320	11.56	1.9	3.3			100	112	132			
	+ PAM - IEC	3.78	370.6	310	12.03	1.9	3.2			100	112	132			
		3.30	424.2	310	13.77	1.7	3.0			100	112	132			
	 133	2.58	541.9	280	15.89	1.5	2.8			100	112	132			
		1.97	712.3	230	17.15	1.4	2.7					132			
	1.46	960.8	220	22.13	0.9	2.4					132				
	1.32	1057.1	200	22.14	0.9	2.3					132				

IEC - PAM bağlantısı yoktur / No IEC - PAM assembling on empty fields / Keine IEC - PAM-Verbindung / Nessun assemblaggio IEC - PAM su campi vuoti / Pas d'assemblage IEC - PAM sur champs vides / Sin montaje IEC - PAM en campos vacíos

63 IEC - PAM bağlantısı yapılır / IEC - PAM assembling available on numbered fields / IEC - PAM-Verbindung möglich / Montaggio IEC - PAM disponibile su campi numerati / Assemblage IEC - PAM disponible sur champs numérotés / Assemblage IEC - PAM disponible sur champs numérotés /













80* IEC - PAM bağlantısı yapılacaksa P_{1max} değerleri aşılmamalıdır / Do not exceed the P_{1max} values indicated on fields with asterisk / Bei IEC - PAM-Verbindungen, sollten die P_{1max}-Werte nicht überschritten werden / Non superare i valori P_{1max} indicati sui campi con l'asterisco / Ne pas dépasser les valeurs P_{1max} indiquées sur les champs avec astérisque / No exceda los valores de P_{1max} indicados en los campos con asterisco

Tip / Type Typ / Tipo Type / Tipo	i _{ges}	4-pol 50Hz 1400rpm n ₂ [min ⁻¹]	M _{amax} f _B =1 4 - pol. [Nm]	W			IEC - PAM										
				P _{1max} 4 - pol. 1400 rpm [kW]	FR1 [kN]	FR2 (a) [kN]	f _B ⇔ 49 - 112										
A603 F603 W 181.13 139 + PAM - IEC 121.02 139	242.67	5.8	3600	2.17	4.0	22.0	90	100*	112*	132*							
	215.56	6.5	3500	2.38	4.0	22.0	90	100*	112*	132*							
	194.31	7.2	3500	2.64	4.0	22.0	90	100*	112*	132*							
	181.13	7.7	3500	2.83	4.0	22.0	90	100*	112*	132*							
	160.90	8.7	3500	3.19	3.9	22.0	90	100	112*	132*							
	143.57	9.8	3500	3.57	3.9	22.0	90	100	112*	132*							
	134.25	10.4	3500	3.82	3.9	22.0		100	112*	132*	160*						
	121.02	11.6	3500	4.24	3.9	22.0		100	112*	132*	160*						
	100.21	14.0	3500	5.12	3.9	22.0		100	112	132*	160*						
	93.60	15.0	3500	5.48	3.8	22.0		100	112	132*	160*						
	84.37	16.6	3500	6.08	3.8	22.0		100	112	132*	160*						
	79.98	17.5	3500	6.42	3.8	22.0		100	112	132*	160*						
	69.87	20.0	3500	7.34	3.7	22.0		100	112	132*	160*						
	55.75	25.1	3500	9.20	3.7	22.0				132	160*						
	A602 F602 W 38.00 139 + PAM - IEC 25.57 139	50.91	27.5	3300	9.50	3.6	22.0	100	112	132							
		45.27	30.9	3300	10.69	3.6	22.0	100	112	132	160*						
40.81		34.3	3300	11.85	3.5	21.7	100	112	132	160*							
38.00		36.8	2800	10.80	3.6	22.0	100	112	132								
33.79		41.4	3200	13.88	3.4	20.0	100	112	132	160*							
30.35		46.1	3200	15.46	3.4	18.9	100	112	132	160							
28.36		49.4	3300	17.06	3.3	17.8	100	112	132	160	180*						
25.57		54.8	3300	18.92	3.2	16.8	100	112	132	160	180*						
23.66		59.2	3300	20.45	3.1	16.1	100	112	132	160	180*						
21.17		66.1	3200	22.16	3.1	15.4	100	112	132	160	180						
19.59		71.5	3200	23.94	3.0	14.7	100	112	132	160	180						
17.60		79.5	3200	26.65	2.9	13.8	100	112	132	160	180						
15.87		88.2	3200	29.56	2.7	12.9	100	112	132	160	180						
13.14		106.5	3100	34.59	2.5	11.8	100	112	132	160	180						
10.91		128.3	3000	40.31	2.2	10.8			132	160	180						
9.83		142.4	2800	41.74	2.2	10.8			132	160	180						
8.14	171.9	2500	45.01	2.0	10.6			132	160	180							
6.92	202.4	2300	48.74	1.8	10.4			132	160	180							
6.24	224.5	2000	47.02	1.9	10.9			132	160	180							
5.16	271.1	1800	51.10	1.7	10.5			132	160	180							
A601 F601 W 5.20 137 + PAM - IEC 3.23 137	8.30	168.7	650	11.48	3.4	5.0	100	112	132	160*							
	7.45	187.8	650	12.78	3.4	5.0	100	112	132	160*							
	6.15	227.5	640	15.25	3.3	4.9	100	112	132	160							
	5.20	269.2	620	17.48	3.1	4.6	100	112	132	160	180*						
	4.81	290.9	620	18.89	3.1	4.4	100	112	132	160	180*						
	4.28	327.3	610	20.90	3.0	4.2			132	160	180*						
	3.65	383.6	600	24.10	2.8	3.9	100	112	132	160	180						
	3.23	433.8	600	27.25	2.7	3.7	100	112	132	160	180						
	2.44	572.7	550	32.98	2.4	3.4			132	160	180						
	2.00	700.0	450	32.98	2.4	3.3			132	160	180						
	1.38	1011.1	450	47.64	1.7	2.8			132	160	180						
1.27	1103.8	400	46.23	1.8	2.8			132	160	180							

IEC - PAM bağlantısı yoktur / No IEC - PAM assembling on empty fields / Keine IEC - PAM-Verbindung / Nessun assemblaggio IEC - PAM su campi vuoti / Pas d'assemblage IEC - PAM sur champs vides / Sin montaje IEC - PAM en campos vacíos

63 IEC - PAM bağlantısı yapılır / IEC - PAM assembling available on numbered fields / IEC - PAM-Verbindung möglich / Montaggio IEC - PAM disponibile su campi numerati / Assemblage IEC - PAM disponible sur champs numérotés / Assemblage IEC - PAM disponible sur champs numérotés /

80* IEC - PAM bağlantısı yapılacaksa P_{1max} değerleri aşılmamalıdır / Do not exceed the P_{1max} values indicated on fields with asterisk / Bei IEC - PAM-Verbindungen, sollten die P_{1max}-Werte nicht überschritten werden / Non superare i valori P_{1max} indicati sui campi con l'asterisco / Ne pas dépasser les valeurs P_{1max} indiquées sur les champs avec astérisque / No exceda los valores de P_{1max} indicados en los campos con asterisco

Tip / Type Typ / Tipo Type / Tipo	i _{ges}	4-pol 50Hz 1400rpm n ₂ [min ⁻¹]	M _{amax} f _B =1 4 - pol. [Nm]	W			IEC - PAM								
				P _{1max} 4 - pol. 1400 rpm [kW]	FR1 [kN]	FR2 (a) [kN]	f _B ⇔  49 - 112								
A703	260.15	5.4	5000	2.82	3.9	30.0	100*	112*	132*						
F703	231.34	6.1	5000	3.17	3.9	30.0	100	112*	132*	160*	180*				
W	207.78	6.7	5000	3.53	3.9	30.0	100	112*	132*	160*	180*				
	189.54	7.4	5000	3.87	3.9	30.0	100	112*	132*	160*	180*				
 143	173.11	8.1	5000	4.23	3.9	30.0	100	112*	132*	160*	180*				
+	155.48	9.0	5000	4.71	3.8	30.0	100	112*	132*	160*	180*				
PAM - IEC	144.94	9.7	5000	5.06	3.8	30.0	100	112	132*	160*	180*	200*			
	128.35	10.9	5000	5.71	3.8	30.0	100	112	132*	160*	180*				
 143	118.75	11.8	5000	6.17	3.8	30.0	100	112	132*	160*	180*	200*			
	108.46	12.9	5000	6.76	3.8	30.0	100	112	132*	160*	180*	200*			
	100.38	13.9	5000	7.30	3.7	30.0	100	112	132*	160*	180*	200*			
	89.95	15.6	5000	8.15	3.7	30.0	100	112	132*	160*	180*	200*			
	83.35	16.8	5000	8.79	3.7	30.0	100	112	132*	160*	180*	200*			
	73.70	19.0	5000	9.95	3.6	30.0	100	112	132	160*	180*	200*			
	67.31	20.8	5000	10.89	3.6	30.0	100	112	132	160*	180*	200*			
	55.75	25.1	5000	13.15	3.5	30.0			132	160*	180*	200*			
	45.67	30.7	5000	16.05	3.4	30.0			132	160	180*	200*			
A702	44.67	31.3	5000	16.41	3.4	30.0	132	160	180*						
F702	36.60	38.3	5000	20.03	3.2	30.0	132	160	180*						
W	33.43	41.9	5000	21.93	3.2	29.5	132	160	180*						
	30.27	46.2	5000	24.21	3.1	28.0	132	160	180						
 143	27.87	50.2	5000	26.30	3.0	26.8	132	160	180	200*					
+	24.80	56.4	5000	29.55	2.9	25.2	132	160	180						
PAM - IEC	22.84	61.3	5000	32.10	2.8	24.1	132	160	180	200					
	20.86	67.1	5000	35.14	2.6	22.9	132	160	180	200					
 143	19.60	71.4	5000	37.40	2.6	22.1	132	160	180	200					
	17.18	81.5	4800	40.95	2.4	21.1	132	160	180						
	14.08	99.5	4600	47.90	2.1	19.4	132	160	180						
	12.86	108.9	4400	50.17	2.0	19.0	132	160	180						
	10.53	132.9	4000	55.68	1.8	18.2		160	180	200					
	8.63	162.3	3800	64.57	1.5	16.9		160	180	200					
	7.88	177.7	3700	68.83	1.3	16.3		160	180	200					
	7.20	194.6	3600	73.34	1.1	15.8		160	180	200					
	5.90	237.5	3200	79.57	0.9	15.3		160	180	200					
	5.38	260.0	3000	81.68	0.8	15.2		160	180	200					
A701	7.80	179.5	1000	18.79	3.2	6.0	132	160	180*						
F701	6.33	221.1	900	20.83	3.1	6.0	132	160	180*						
W	5.29	264.9	880	24.41	3.0	5.8	132	160	180						
	4.87	287.7	870	26.21	2.9	5.6	132	160	180	200*					
 141	4.18	335.2	850	29.84	2.7	5.3	132	160	180	200*					
+	3.63	385.5	850	34.31	2.6	5.0	132	160	180	200					
PAM - IEC	3.19	438.8	820	37.68	2.4	4.8	132	160	180						
	3.00	466.7	800	39.09	2.4	4.7	132	160	180						
 141	2.52	555.6	800	46.54	2.1	4.3	132	160	180						
	2.03	688.1	750	54.04	1.8	4.0	132	160	180	200					
	1.84	761.4	700	55.81	1.7	3.9		160	180	200					
	1.44	969.2	700	71.04	1.1	3.5		160	180	200					
	1.26	1114.3	650	75.84	0.9	3.4		160	180	200					

 **IEC - PAM bağlantısı yoktur** / No IEC - PAM assembling on empty fields / Keine IEC - PAM-Verbindung / Nessun assemblaggio IEC - PAM su campi vuoti / Pas d'assemblage IEC - PAM sur champs vides / Sin montaje IEC - PAM en campos vacíos

 **63** **IEC - PAM bağlantısı yapılır** / IEC - PAM assembling available on numbered fields / IEC - PAM-Verbindung möglich / Montaggio IEC - PAM disponibile su campi numerati / Assemblage IEC - PAM disponible sur champs numérotés / Assemblage IEC - PAM disponible sur champs numérotés /

 **80*** **IEC - PAM bağlantısı yapılacaksa P_{1max} değerleri aşılmamalıdır** / Do not exceed the P_{1max} values indicated on fields with asterisk / Bei IEC - PAM-Verbindungen, sollten die P_{1max}-Werte nicht überschritten werden / Non superare i valori P_{1max} indicati sui campi con l'asterisco / Ne pas dépasser les valeurs P_{1max} indiquées sur les champs avec astérisque / No exceda los valores de P_{1max} indicados en los campos con asterisco

Tip / Type Typ / Tipo Type / Tipo	i _{ges}	4-pol 50Hz 1400rpm n ₂ [min ⁻¹]	M _{amax} f _B =1 4 - pol. [Nm]	W			IEC - PAM							
				P _{1max} 4 - pol. 1400 rpm [kW]	FR1 [kN]	FR2 (a) [kN]	f _B ⇔ 49 - 112							
A903	205.73	6.8	8000	5.70	8.0	55.0	132*	160*	180*					
F903	185.64	7.5	8000	6.32	8.0	55.0	132*	160*	180*					
W	154.07	9.1	8000	7.61	8.0	55.0	132*	160*	180*					
145	139.41	10.0	8000	8.41	8.0	55.0	132*	160*	180*					
145	128.36	10.9	8000	9.14	8.0	55.0	132*	160*	180*	200*				
+	115.83	12.1	8000	10.13	8.0	55.0	132	160*	180*	200*				
PAM - IEC	104.41	13.4	8000	11.23	8.0	55.0	132	160*	180*					
145	96.13	14.6	8000	12.20	8.0	55.0	132	160*	180*	200*				
145	86.43	16.2	8000	13.57	8.0	55.0	132	160*	180*	200*				
	79.13	17.7	8000	14.82	8.0	55.0	132	160*	180*	200*				
	71.40	19.6	8000	16.43	8.0	54.3	132	160	180*	200*				
	63.02	22.2	8000	18.61	8.0	51.2	132	160	180*	200*				
	59.26	23.6	8000	19.79	8.0	49.6	132	160	180*	200*				
	53.66	26.1	8000	21.86	8.0	47.2	132	160	180*	200*				
	48.50	28.9	8000	24.18	8.0	44.9		160	180	200*				
A902	42.47	33.0	8000	27.61	5.1	42.3	160	180	200*	225*				
F902	38.33	36.5	8000	30.60	5.1	40.1	160	180	200	225*				
W	31.81	44.0	8000	36.87	5.1	36.3	160	180	200	225*				
145	26.38	53.1	8000	44.46	5.1	32.3	160	180	200	225*				
145	23.80	58.8	8000	49.28	5.1	30.8	160	180	200	225				
+	19.75	70.9	8000	59.37	5.1	27.5	160	180	200	225				
PAM - IEC	17.18	81.5	7900	67.42	5.1	25.5	160	180	200	225				
145	15.50	90.3	7800	73.77	5.1	24.2	160	180	200	225				
145	12.86	108.8	7300	83.19	5.1	22.9	160	180	200	225				
	10.28	136.2	7200	102.69	5.0	20.0	160	180	200	225				
	9.28	150.9	6500	102.74	5.0	20.7	160	180	200	225				
	7.70	181.9	5300	100.94	5.0	21.9	160	180	200	225				
	6.89	203.2	5000	106.38	4.0	21.5	160	180	200	225				
	6.22	225.2	4900	115.54	4.0	20.6	160	180	200	225				
	5.16	271.3	4600	130.69	4.0	19.4	160	180	200	225				

IEC - PAM bağlantısı yoktur / No IEC - PAM assembling on empty fields / Keine IEC - PAM-Verbindung / Nessun assemblaggio IEC - PAM su campi vuoti / Pas d'assemblage IEC - PAM sur champs vides / Sin montaje IEC - PAM en campos vacíos

63 **IEC - PAM bağlantısı yapılır / IEC - PAM assembling available on numbered fields / IEC - PAM-Verbindung möglich / Montaggio IEC - PAM disponibile su campi numerati / Assemblage IEC - PAM disponible sur champs numérotés / Assemblage IEC - PAM disponible sur champs numérotés /**

80* **IEC - PAM bağlantısı yapılacaksa P_{1max} değerleri aşılmamalıdır / Do not exceed the P_{1max} values indicated on fields with asterisk / Bei IEC - PAM-Verbindungen, sollten die P_{1max}-Werte nicht überschritten werden / Non superare i valori P_{1max} indicati sui campi con l'asterisco / Ne pas dépasser les valeurs P_{1max} indiquées sur les champs avec astérisque / No exceda los valores de P_{1max} indicados en los campos con asterisco**



A large area of the page is filled with horizontal dotted lines, providing a template for writing or drawing.

TR GENEL PARÇA LİSTESİ
IT GENERALE ELENCO DELLE PARTI

EN GENERAL PART LIST
FR GÉNÉRALE LA LISTE DES PIÈCES

DE ALLGEMEINE TEILELISTE
ES LISTE DE PIEZAS EN GENERAL

A / F / AF 252 ... 902

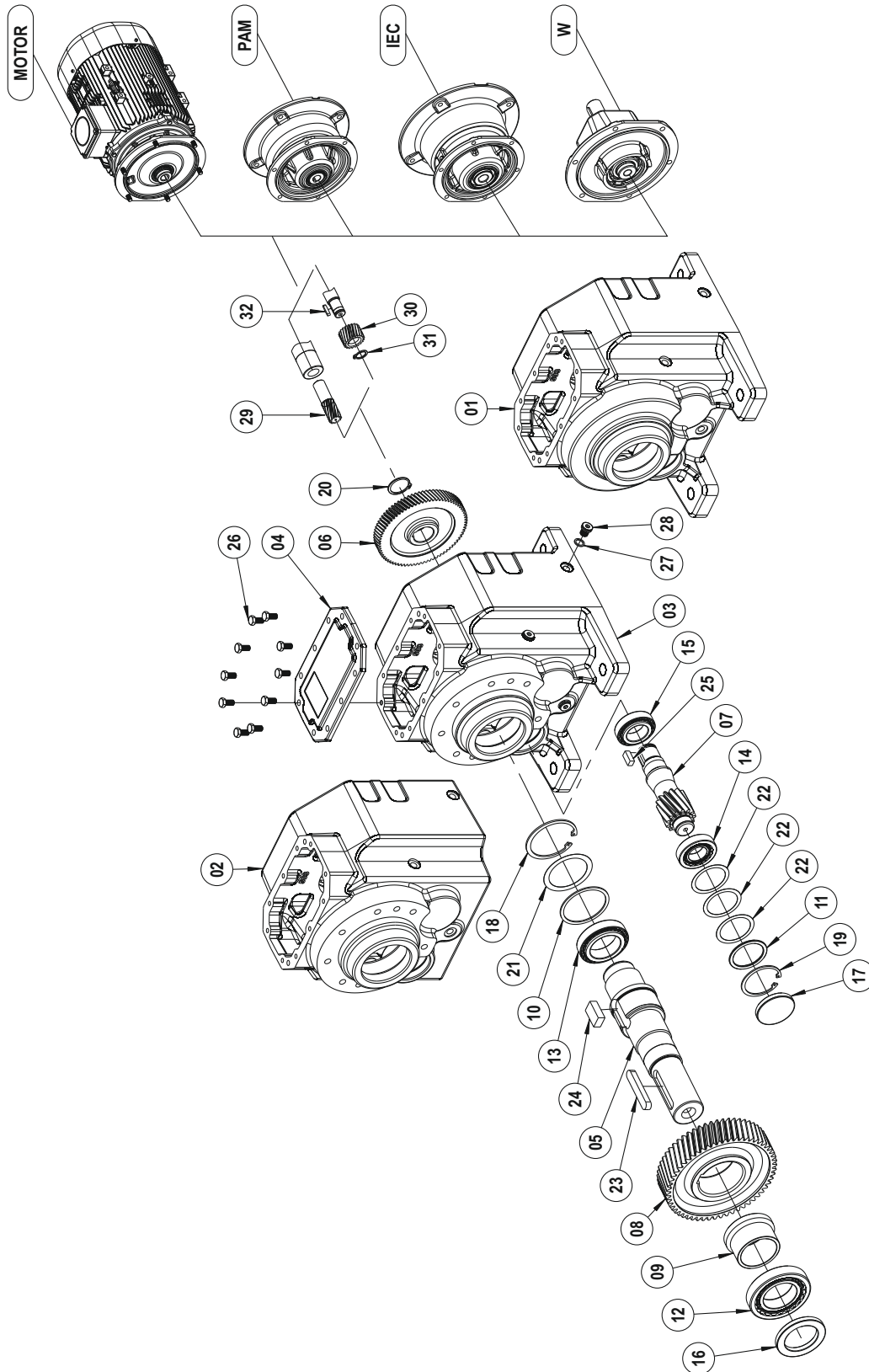

TR GENEL PARÇA LİSTESİ

EN GENERAL PART LIST

DE ALLGEMEINE TEILELISTE

IT GENERALE ELENCO DELLE PARTI

FR GÉNÉRALE LA LISTE DES PIÈCES

ES LISTE DE PIEZAS EN GENERAL

01	A Gövde	Gear Case	Gehäuse	Ingranaggi Box	Carter d'engrenage	La caja de engranajes
02	F Gövde	Gear Case	Gehäuse	Ingranaggi Box	Carter d'engrenage	La caja de engranajes
03	AF Gövde	Gear Case	Gehäuse	Ingranaggi Box	Carter d'engrenage	La caja de engranajes
04	Kapak	Cover	Abdeckung	Coperchio	Couverture	Cubierta
05	Çıkış Mili	Output Solid Shaft	Abtriebswelle	Albero di uscita	l'arbre de sortie	Eje de salida
06	Z2 Dişlisi	Driving Gear	Antriebsrad	Ingranaggio Conduttore	Rove d'entrée	Engranaje con ducido
07	Z3 Dişlisi	Pinion Shaft	Ritzelwelle	Pignone	Arbre intermédiaire	Deleje del piñón
08	Z4 Dişlisi	Driven Gear	Abtriebsrad	Ingranaggio Condotto	Rove de sortie	Engranaje conducido
09	Burç	Spacer	Distanzbuchse	Distanziatore	Doville entretoise	Espaciador
10	Rondela	Washer	Distanzscheibe	Rondella	Rondelle	El apoyo a disco
11	Rondela	Washer	Distanzscheibe	Rondella	Rondelle	El apoyo a disco
12	Rulman	Bearing	Kugellager	Cuscinetto	Roulement à billes	Rodamiento de bolas
13	Rulman	Bearing	Kugellager	Cuscinetto	Roulement à billes	Rodamiento de bolas
14	Rulman	Bearing	Kugellager	Cuscinetto	Roulement à billes	Rodamiento de bolas
15	Rulman	Bearing	Kugellager	Cuscinetto	Roulement à billes	Rodamiento de bolas
16	Yağ Keçesi	Oil Seal	Öldichtung	Paraolio	Bague d'étancheite	sello de aceite
17	Yağ Kapağı	Oil Cover	Ölabdeckung	Tappo di chiusura	bouchon d'huile	Tapón de cierre
18	Segman (DIN 472)	Circlip (DIN 472)	Sicherungsring (DIN 472)	Anello di sicurezza (DIN 472)	Circlip (DIN 472)	Anillo de seguridad (DIN 472)
19	Segman (DIN 472)	Circlip (DIN 472)	Sicherungsring (DIN 472)	Anello di sicurezza (DIN 472)	Circlip (DIN 472)	Anillo de seguridad (DIN 472)
20	Segman (DIN 471)	Circlip (DIN 471)	Sicherungsring (DIN 471)	Anello di sicurezza (DIN 471)	Circlip (DIN 471)	Anillo de seguridad (DIN 471)
21	Layner	Shim	Passscheibe	Shim	Rondelle d'ajustage	Calce
22	Layner	Shim	Passscheibe	Shim	Rondelle d'ajustage	Calce
23	Kama	Key	Passfeder	Chiavetta	Clavette	Clave
24	Kama	Key	Passfeder	Chiavetta	Clavette	Clave
25	Kama	Key	Passfeder	Chiavetta	Clavette	Clave
26	Cıvata (DIN 933)	Bolt (DIN 933)	Verschrauben (DIN 933)	Bullone (DIN 933)	Boulonner (DIN 933)	Atornillar (DIN 933)
27	Rondela (DIN 7603)	Washer (DIN 7603)	Distanzscheibe (DIN 7603)	Rondella (DIN 7603)	Rondelle (DIN 7603)	El apoyo a disco (DIN 7603)
28	Yağ Tapası	Oil Plug	Ölstöpsel	Olio Tappo	Visde vidange	Tapón
29	Z1 Dişlisi	Driving Pinion	Antriebsritzel	Ingresso Pignone	Pignon d'entrée	Piñón de entrada
30	Z1 Dişlisi (Kamalı)	Driving Pinion (With Key)	Antriebsritzel (Mit Passfeder)	Ingresso Pignone (Con chiavetta)	Pignon d'entrée (Avec clavette)	Piñón de entrada (Con clave)
31	Segman (DIN 471)	Circlip (DIN 471)	Sicherungsring (DIN 471)	Anello di sicurezza (DIN 471)	Circlip (DIN 471)	Anillo de seguridad (DIN 471)
32	Kama	Key	Passfeder	Chiavetta	Clavette	Clave

TR GENEL PARÇA LİSTESİ

EN GENERAL PART LIST

DE ALLGEMEINE TEILELISTE

IT GENERALE ELENCO DELLE PARTI

FR GÉNÉRALE LA LISTE DES PIÈCES

ES LISTE DE PIEZAS EN GENERAL

A / F / AF 253 ... 903

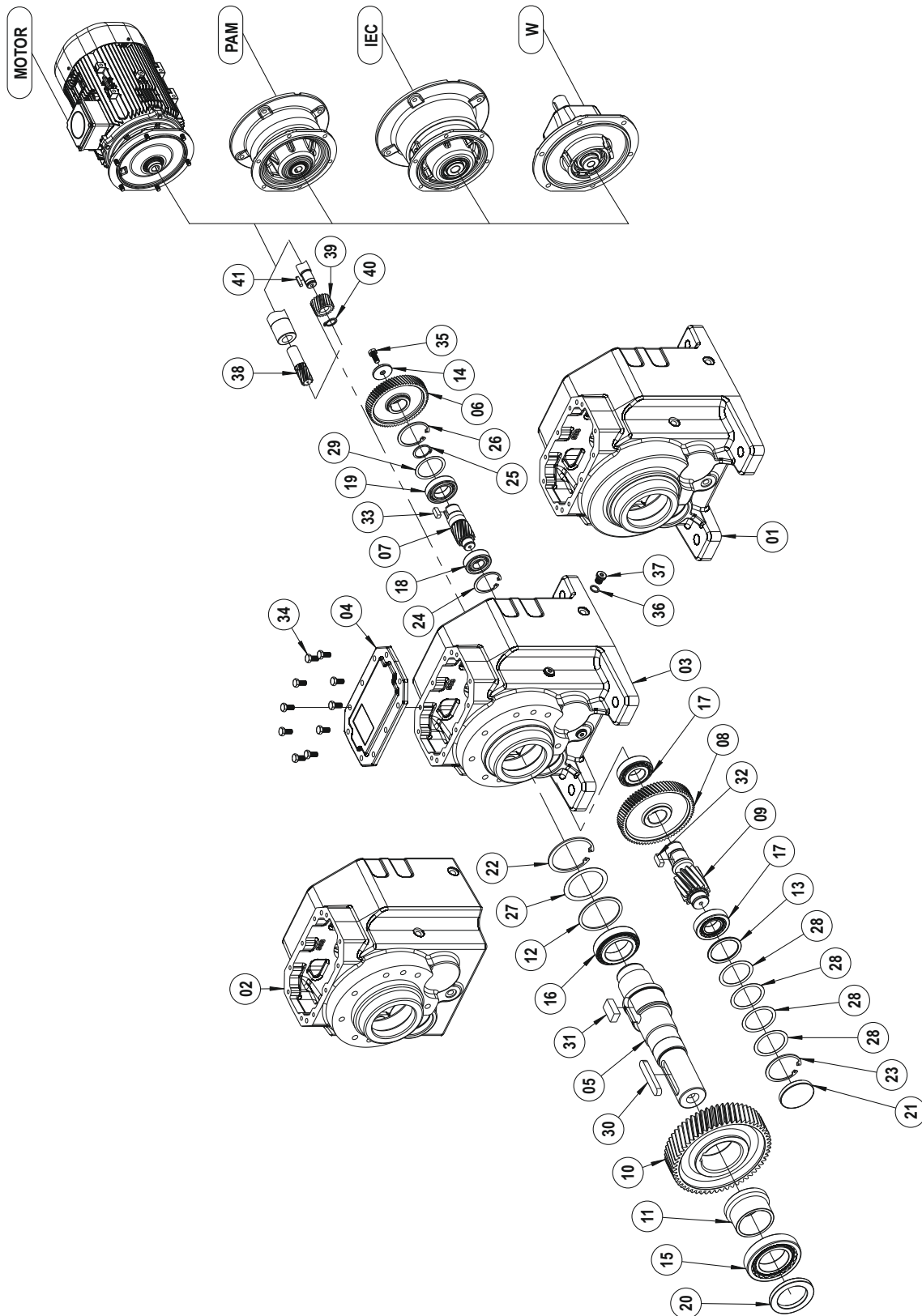

TR GENEL PARÇA LİSTESİ

EN GENERAL PART LIST

DE ALLGEMEINE TEILELISTE

IT GENERALE ELENCO DELLE PARTI

FR GÉNÉRALE LA LISTE DES PIÈCES

ES LISTE DE PIEZAS EN GENERAL

01	A Gövde	Gear Case	Gehäuse	Ingranaggi Box	Carter d'engrenage	La caja de engranajes
02	F Gövde	Gear Case	Gehäuse	Ingranaggi Box	Carter d'engrenage	La caja de engranajes
03	AF Gövde	Gear Case	Gehäuse	Ingranaggi Box	Carter d'engrenage	La caja de engranajes
04	Kapak	Cover	Abdeckung	Coperchio	Couverture	Cubierta
05	Çıkış Mili	Output Solid Shaft	Abtriebswelle	Albero di uscita	l'arbre de sortie	Eje de salida
06	Z2 Dişlisi	Driving Gear	Antriebsrad	Ingranaggio Conduttore	Rove d'entrée	Engranaje con ducido
07	Z3 Dişlisi	Pinion Shaft	Ritzelwelle	Pignone	Arbre intermédiaire	Deleje del piñón
08	Z4 Dişlisi	Driven Gear	Abtriebsrad	Ingranaggio Condotta	Rove de sortie	Engranaje conducido
09	Z5 Dişlisi	Pinion Shaft	Ritzelwelle	Pignone di uscita	Arbre de pignon de sortie	El eje de piñón de salida
10	Z6 Dişlisi	Driven Gear	Abtriebsrad	Albero di uscita	l'arbre de sortie	Eje de salida
11	Burç	Spacer	Distanzbuchse	Distanziatore	Doville entretoise	Espaciador
12	Rondela	Washer	Distanzscheibe	Rondella	Rondelle	El apoyo a disco
13	Rondela	Washer	Distanzscheibe	Rondella	Rondelle	El apoyo a disco
14	Rondela	Washer	Distanzscheibe	Rondella	Rondelle	El apoyo a disco
15	Rulman	Bearing	Kugellager	Cuscinetto	Roulement à billes	Rodamiento de bolas
16	Rulman	Bearing	Kugellager	Cuscinetto	Roulement à billes	Rodamiento de bolas
17	Rulman	Bearing	Kugellager	Cuscinetto	Roulement à billes	Rodamiento de bolas
18	Rulman	Bearing	Kugellager	Cuscinetto	Roulement à billes	Rodamiento de bolas
19	Rulman	Bearing	Kugellager	Cuscinetto	Roulement à billes	Rodamiento de bolas
20	Yağ Keçesi	Oil Seal	Öldichtung	Paraolio	Bague d'étancheite	sello de aceite
21	Yağ Kapağı	Oil Cover	Ölabdeckung	Tappo di chiusura	bouchon d'huile	Tapón de cierre
22	Segman (DIN 472)	Circlip (DIN 472)	Sicherungsring (DIN 472)	Anello di sicurezza (DIN 472)	Circlip (DIN 472)	Anillo de seguridad (DIN 472)
23	Segman (DIN 472)	Circlip (DIN 472)	Sicherungsring (DIN 472)	Anello di sicurezza (DIN 472)	Circlip (DIN 472)	Anillo de seguridad (DIN 472)
24	Segman (DIN 472)	Circlip (DIN 472)	Sicherungsring (DIN 472)	Anello di sicurezza (DIN 472)	Circlip (DIN 472)	Anillo de seguridad (DIN 472)
25	Segman (DIN 471)	Circlip (DIN 471)	Sicherungsring (DIN 471)	Anello di sicurezza (DIN 471)	Circlip (DIN 471)	Anillo de seguridad (DIN 471)
26	Segman (DIN 472)	Circlip (DIN 472)	Sicherungsring (DIN 472)	Anello di sicurezza (DIN 472)	Circlip (DIN 472)	Anillo de seguridad (DIN 472)
27	Layner	Shim	Passscheibe	Shim	Rondelle d'ajustage	Calce
28	Layner	Shim	Passscheibe	Shim	Rondelle d'ajustage	Calce
29	Layner	Shim	Passscheibe	Shim	Rondelle d'ajustage	Calce
30	Kama	Key	Passfeder	Chiavetta	Clavette	Clave
31	Kama	Key	Passfeder	Chiavetta	Clavette	Clave
32	Kama	Key	Passfeder	Chiavetta	Clavette	Clave
33	Kama	Key	Passfeder	Chiavetta	Clavette	Clave
34	Cıvata (DIN 933)	Bolt (DIN 933)	Verschrauben (DIN 933)	Bullone (DIN 933)	Boulonner (DIN 933)	Atornillar (DIN 933)
35	Cıvata (DIN 933)	Bolt (DIN 933)	Verschrauben (DIN 933)	Bullone (DIN 933)	Boulonner (DIN 933)	Atornillar (DIN 933)
36	Rondela (DIN 7603)	Washer (DIN 7603)	Distanzscheibe (DIN 7603)	Rondella (DIN 7603)	Rondelle (DIN 7603)	El apoyo a disco (DIN 7603)
37	Yağ Tapası	Oil Plug	Ölstöpsel	Olio Tappo	Visde vidange	Tapón
38	Z1 Dişlisi	Driving Pinion	Antriebsritzel	Ingresso Pignone	Pignon d'entrée	Piñón de entrada
39	Z1 Dişlisi (Kamalı)	Driving Pinion (With Key)	Antriebsritzel (Mit Passfeder)	Ingresso Pignone (Con chiavetta)	Pignon d'entrée (Avec clavette)	Piñón de entrada (Con clave)
40	Segman (DIN 471)	Circlip (DIN 471)	Sicherungsring (DIN 471)	Anello di sicurezza (DIN 471)	Circlip (DIN 471)	Anillo de seguridad (DIN 471)
41	Kama	Key	Passfeder	Chiavetta	Clavette	Clave

TR GENEL PARÇA LİSTESİ

EN GENERAL PART LIST

DE ALLGEMEINE TEILELISTE

IT GENERALE ELENCO DELLE PARTI

FR GÉNÉRALE LA LISTE DES PIÈCES

ES LISTE DE PIEZAS EN GENERAL

A / F / AF / AFM 301 ... 701

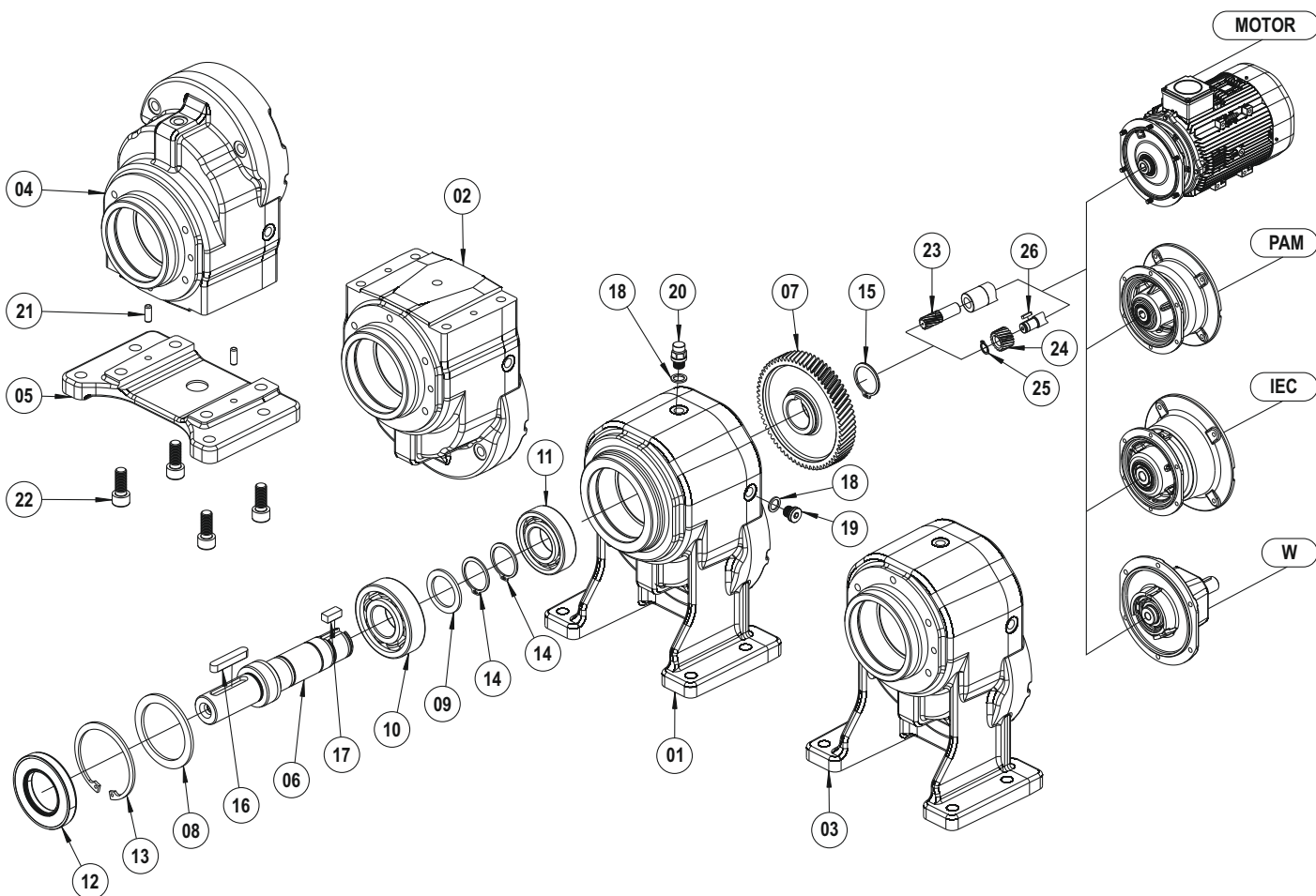

01	A Gövde	Gear Case	Gehäuse	Ingranaggi Box	Carter d'engrenage	La caja de engranajes
02	F Gövde	Gear Case	Gehäuse	Ingranaggi Box	Carter d'engrenage	La caja de engranajes
03	AF Gövde	Gear Case	Gehäuse	Ingranaggi Box	Carter d'engrenage	La caja de engranajes
04	AF-F-M Gövde	Gear Case	Gehäuse	Ingranaggi Box	Carter d'engrenage	La caja de engranajes
05	Ayak	Foot	Fuss	Piede	Pied	Pie
06	Çıkış Mili	Output Solid Shaft	Abtriebswelle	Albero di uscita	Arbre de sortie	Eje de salida
07	Z2 Dişlisi	Driving Gear	Antriebsrad	Ingranaggio Conduttore	Rove d'entrée	Engranaje con ducido
08	Rondela	Washer	Distanzscheibe	Rondella	Rondelle	El apoyo a disco
09	Rondela	Washer	Distanzscheibe	Rondella	Rondelle	El apoyo a disco
10	Rulman	Bearing	Kugellager	Cuscinetto	Roulement à billes	Rodamiento de bolas
11	Rulman	Bearing	Kugellager	Cuscinetto	Roulement à billes	Rodamiento de bolas
12	Yağ Keçesi	Oil Seal	Öldichtung	Paraolio	Bague d'etancheite	sello de aceite
13	Segman (DIN 472)	Circlip (DIN 472)	Sicherungsring (DIN 472)	Anello di sicurezza (DIN 472)	Circlip (DIN 472)	Anillo de seguridad (DIN 472)
14	Segman (DIN 471)	Circlip (DIN 472)	Sicherungsring (DIN 472)	Anello di sicurezza (DIN 472)	Circlip (DIN 472)	Anillo de seguridad (DIN 472)
15	Segman (DIN 471)	Circlip (DIN 471)	Sicherungsring (DIN 471)	Anello di sicurezza (DIN 471)	Circlip (DIN 471)	Anillo de seguridad (DIN 471)
16	Kama	Key	Passfeder	Chiavetta	Clavette	Clave
17	Kama	Key	Passfeder	Chiavetta	Clavette	Clave
18	Rondela (7603)	Washer (DIN 7603)	Distanzscheibe (DIN 7603)	Rondella (DIN 7603)	Rondelle (DIN 7603)	El apoyo a disco (DIN 7603)
19	Yağ Tapası	Oil Plug	Ölstöpsel	Olio Tappo	Visde vidange	Tapón
20	Havalandırma Tapası	Vent Plug	Entlüftungsstopfen	Tappo di sfiato	Évent	Ventilación
21	Pim	Pin	Bolzen	Pin	Goupille	Pasador
22	Civata (DIN 912)	Bolt (DIN 912)	Verschrauben (DIN 912)	Bullone (DIN 912)	Boulonner (DIN 912)	Atornillar (DIN 912)
23	Z1 Dişlisi	Driving Pinion	Antriebsritzel	Ingresso Pignone	Pignon d'entrée	Piñón de entrada
24	Z1 Dişlisi (Kamalı)	Driving Pinion (With Key)	Antriebsritzel (Mit Passfeder)	Ingresso Pignone (Con chiavetta)	Pignon d'entrée (Avec clavette)	Piñón de entrada (Con clave)
25	Segman (DIN 471)	Circlip (DIN 471)	Sicherungsring (DIN 471)	Anello di sicurezza (DIN 471)	Circlip (DIN 471)	Anillo de seguridad (DIN 471)
26	Kama	Key	Passfeder	Chiavetta	Clavette	Clave

TR GENEL PARÇA LİSTESİ

EN GENERAL PART LIST

DE ALLGEMEINE TEILELISTE

IT GENERALE ELENCO DELLE PARTI

FR GÉNÉRALE LA LISTE DES PIÈCES

ES LISTE DE PIEZAS EN GENERAL

A / F / AF 202 ... 202G

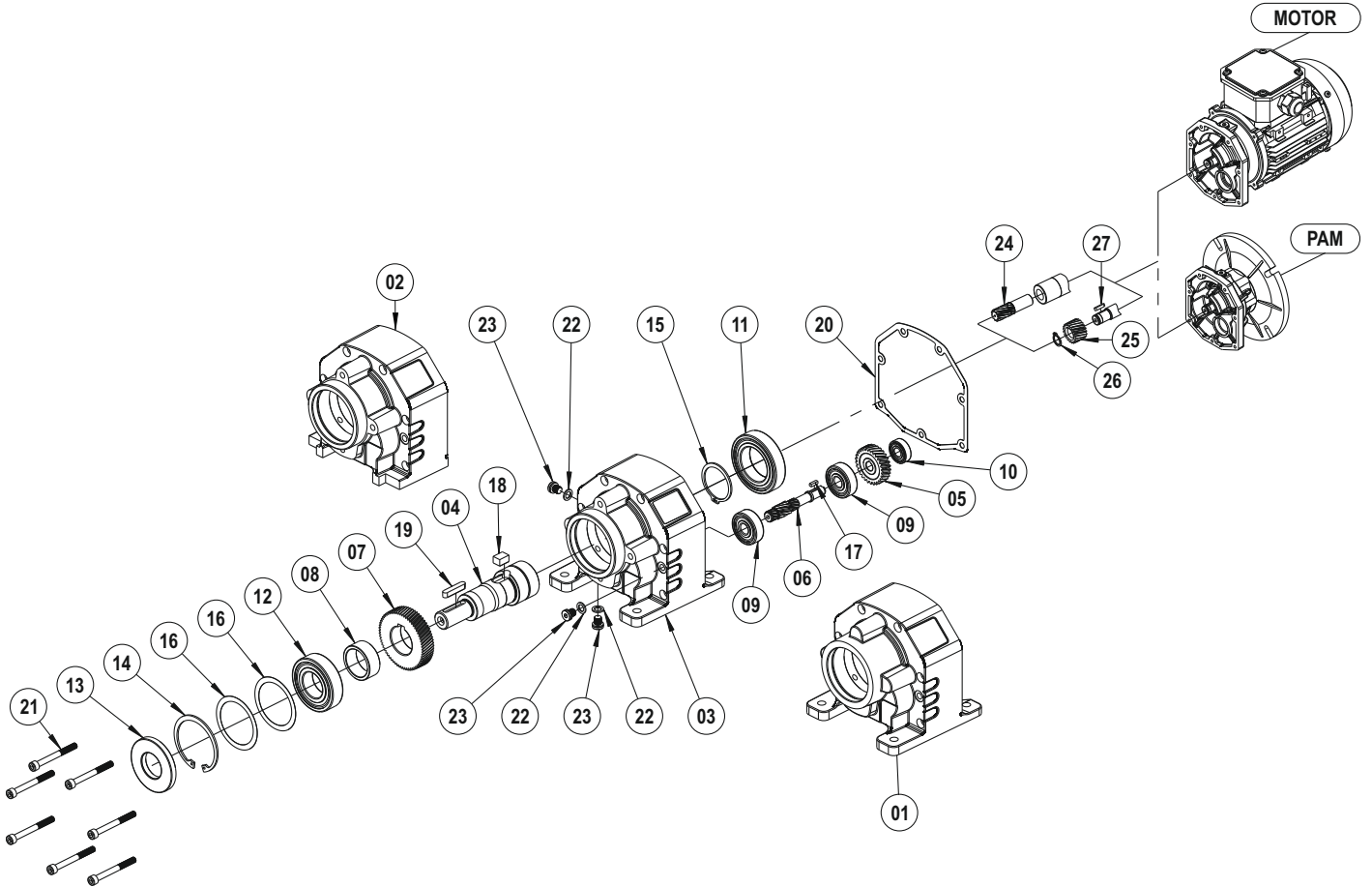

01	A Gövde	Gear Case	Gehäuse	Ingranaggi Box	Carter d'engrenage	La caja de engranajes
02	F Gövde	Gear Case	Gehäuse	Ingranaggi Box	Carter d'engrenage	La caja de engranajes
03	AF Gövde	Gear Case	Gehäuse	Ingranaggi Box	Carter d'engrenage	La caja de engranajes
04	Çıkış Mili	Output Solid Shaft	Abtriebswelle	Albero di uscita	Arbre de sortie	Eje de salida
05	Z2 Dişlisi	Driving Gear	Antriebsrad	Ingranaggio Conduttore	Rove d'entrée	Engranaje con ducido
06	Z3 Dişlisi	Pinion Shaft	Ritzelwelle	Pignone	Arbre intermédiaire	Deleje del piñón
07	Z4 Dişlisi	Driven Gear	Abtriebsrad	Ingranaggio Condotta	Rove de sortie	Engranaje conducido
08	Burç	Spacer	Distanzbuchse	Distanziatore	Doville entretoise	Espaciador
09	Rulman	Bearing	Kugellager	Cuscinetto	Roulement à billes	Rodamiento de bolas
10	Rulman	Bearing	Kugellager	Cuscinetto	Roulement à billes	Rodamiento de bolas
11	Rulman	Bearing	Kugellager	Cuscinetto	Roulement à billes	Rodamiento de bolas
12	Rulman	Bearing	Kugellager	Cuscinetto	Roulement à billes	Rodamiento de bolas
13	Yağ Keçesi	Oil Seal	Öldichtung	Paraolio	Bague d'etancheite	Sello de aceite
14	Segman (DIN 472)	Circlip (DIN 472)	Sicherungsring (DIN 472)	Anello di sicurezza (DIN 472)	Circlip (DIN 472)	Anillo de seguridad (DIN 472)
15	Segman (DIN 471)	Circlip (DIN 471)	Sicherungsring (DIN 471)	Anello di sicurezza (DIN 471)	Circlip (DIN 471)	Anillo de seguridad (DIN 471)
16	Layner	Shim	Passscheibe	Shim	Rondelle d'ajustage	Calce
17	Kama	Key	Passfeder	Chiavetta	Clavette	Clave
18	Kama	Key	Passfeder	Chiavetta	Clavette	Clave
19	Kama	Key	Passfeder	Chiavetta	Clavette	Clave
20	Conta	Gasket	Dichtung	Sigillo	Joint	Sellar
21	Civata (DIN 912)	Bolt (DIN 912)	Verschrauben (DIN 912)	Bullone (DIN 912)	Boulonner (DIN 912)	Atornillar (DIN 912)
22	Rondela (DIN 7603)	Washer (DIN 7603)	Distanzscheibe (DIN 7603)	Rondella (DIN 7603)	Rondelle (DIN 7603)	El apoyo a disco (DIN 7603)
23	Yağ Tapası	Oil Plug	Ölstöpsel	Olio Tappo	Visde vidange	Tapón
24	Z1 Dişlisi	Driving Pinion	Antriebsritzel	Ingresso Pignone	Pignon d'entrée	Piñón de entrada
25	Z1 Dişlisi (Kamalı)	Driving Pinion (With Key)	Antriebsritzel (Mit Passfeder)	Ingresso Pignone (Con chiavetta)	Pignon d'entrée (Avec clavette)	Piñón de entrada (Con clave)
26	Segman (DIN 471)	Circlip (DIN 471)	Sicherungsring (DIN 471)	Anello di sicurezza (DIN 471)	Circlip (DIN 471)	Anillo de seguridad (DIN 471)
27	Kama	Key	Passfeder	Chiavetta	Clavette	Clave

TR GENEL PARÇA LİSTESİ

EN GENERAL PART LIST

DE ALLGEMEINE TEILELISTE

IT GENERALE ELENCO DELLE PARTI

FR GÉNÉRALE LA LISTE DES PIÈCES

ES LISTE DE PIEZAS EN GENERAL

AF / F 301 ... 701 / 252 ... 902 / 253 ... 903 - B5

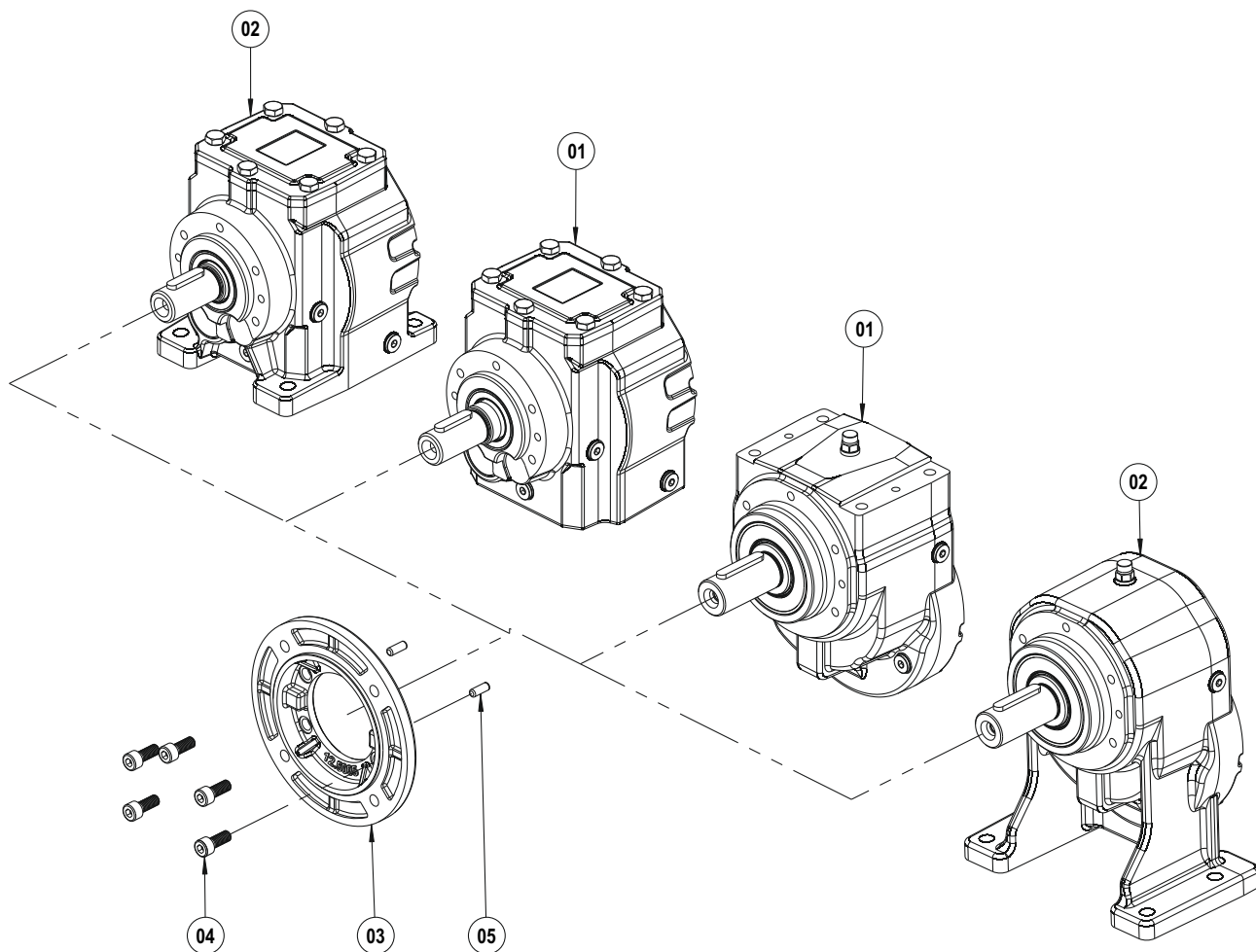

01	F Gövde	Gear Case	Gehäuse	Ingranaggi Box	Carter d'engrenage	La caja de engranajes
02	AF Gövde	Gear Case	Gehäuse	Ingranaggi Box	Carter d'engrenage	La caja de engranajes
03	Çıkış Flanşı	B5 Output Flange	B5 Abtriebsflansch	B5 Flangia d'uscita	B5 Bride sortie	B5 Brida de solida
04	Civata (DIN 912)	Bolt (DIN 912)	Verschrauben (DIN 912)	Bullone (DIN 912)	Boulonner (DIN 912)	Atornillar (DIN 912)
05	Pim	Pin	Bolzen	Pin	Goupille	Pasador

TR GENEL PARÇA LİSTESİ

EN GENERAL PART LIST

DE ALLGEMEINE TEILELISTE

IT GENERALE ELENCO DELLE PARTI

FR GÉNÉRALE LA LISTE DES PIÈCES

ES LISTE DE PIEZAS EN GENERAL

IEC 63 ... 225

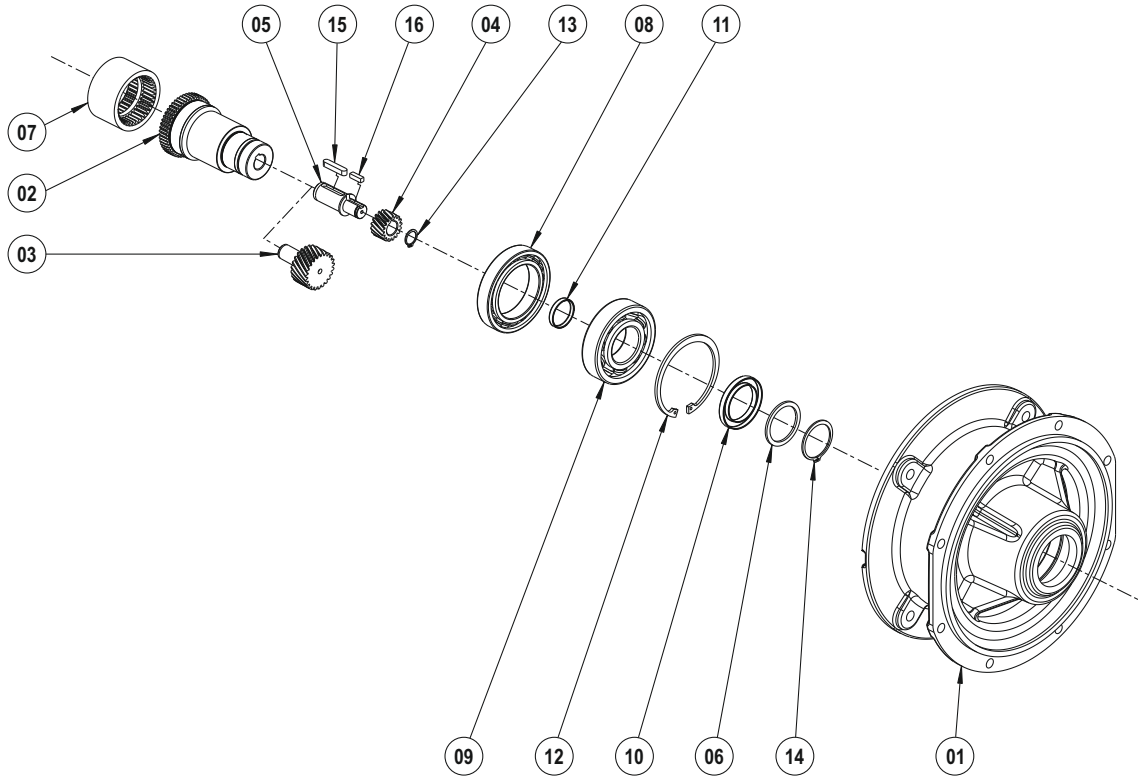

01	Gövde	Gear Case	Gehäuse	Ingranaggi Box	Carter d'engrenage	La caja de engranajes
02	IEC Mili	IEC Shaft	IEC Welle	IEC Albero	IEC Arbre	IEC Eje
03	Z1 Dişlisi	Driving Pinion	Antriebsritzel	Ingresso Pignone	Pignon d'entrée	Piñón de entrada
04	Z1 Dişlisi (Kamalı)	Driving Pinion (With Key)	Antriebsritzel (Mit Passfeder)	Ingresso Pignone (Con chiavetta)	Pignon d'entrée (Avec clavette)	Piñón de entrada (Con clave)
05	Pinyon Mili (Kamalı)	Pinion Shaft (With Key)	Ritzelwelle (Mit Passfeder)	Pignone (Con chiavetta)	Arbre Pignon (Avec clavette)	Eje del piñon (Con clave)
06	Rondela	Washer	Distanzscheibe	Rondella	Rondelle	El apoyo a disco
07	Kaplin	Coupling	Kupplung	Accoppiamento	Accouplement	Enganche
08	Rulman	Bearing	Kugellager	Cuscinetto	Roulement à billes	Rodamiento de bolas
09	Rulman	Bearing	Kugellager	Cuscinetto	Roulement à billes	Rodamiento de bolas
10	Yağ Keçesi	Oil Seal	Öldichtung	Paraolio	Bague d'etancheite	sello de aceite
11	Yağ Kapağı	Oil Cover	Ölabdeckung	Tappo di chiusura	bouchon d'huile	Tapón de cierre
12	Segman (DIN 472)	Circlip (DIN 472)	Sicherungsring (DIN 472)	Anello di sicurezza (DIN 472)	Circlip (DIN 472)	Anillo de seguridad (DIN 472)
13	Segman (DIN 471)	Circlip (DIN 471)	Sicherungsring (DIN 471)	Anello di sicurezza (DIN 471)	Circlip (DIN 471)	Anillo de seguridad (DIN 471)
14	Segman (DIN 471)	Circlip (DIN 471)	Sicherungsring (DIN 471)	Anello di sicurezza (DIN 471)	Circlip (DIN 471)	Anillo de seguridad (DIN 471)
15	Kama	Key	Passfeder	Chiavetta	Clavette	Clave
16	Kama	Key	Passfeder	Chiavetta	Clavette	Clave

TR GENEL PARÇA LİSTESİ

EN GENERAL PART LIST

DE ALLGEMEINE TEILELISTE

IT GENERALE ELENCO DELLE PARTI

FR GÉNÉRALE LA LISTE DES PIÈCES

ES LISTE DE PIEZAS EN GENERAL

**PAM B5 / 56 ... 90
(A / F / AF 202 ... 202G)**

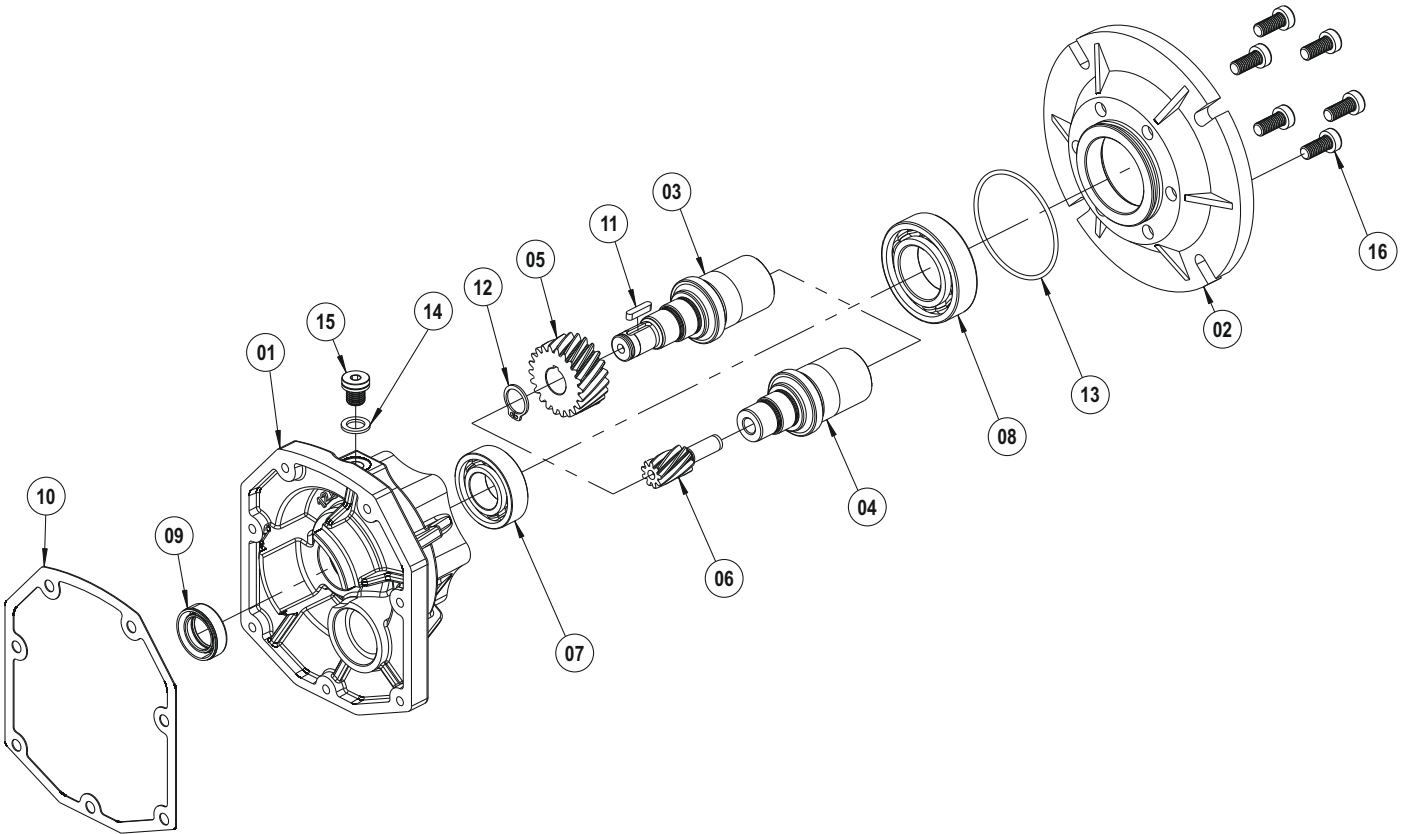

01	Gövde	Gear Case	Gehäuse	Ingranaggi Box	Carter d'engrenage	La caja de engranajes
02	B5 Giriş Flanşı	Input Flange B5	Eingangsflansch B5	Flangia B5	B5 a bride	Brida B5
03	Pam Mili (kamalı)	PAM Shaft (With Key)	PAM Welle (Mit Passfeder)	PAM albero (Con chiavetta)	PAM Arbre (Avec clavette)	PAM eje (Con clave)
04	Pam Mili	PAM Shaft	PAM Welle	PAM albero	PAM Arbre	PAM eje
05	Z1 Dişlisi (kamalı)	Driving Pinion (With Key)	Antriebsritzel (Mit Passfeder)	Ingresso Pignone (Con chiavetta)	Pignon d'entrée (Avec clavette)	Piñón de entrada (Con clave)
06	Z1 Dişlisi	Driving Pinion	Antriebsritzel	Ingresso Pignone	Pignon d'entrée	Piñón de entrada
07	Rulman	Bearing	Kugellager	Cuscinetto	Roulement à billes	Rodamiento de bolas
08	Rulman	Bearing	Kugellager	Cuscinetto	Roulement à billes	Rodamiento de bolas
09	Yağ Keçesi	Oil Seal	Öldichtung	Paraolio	Bague d'etancheite	sello de aceite
10	Conta	Gasket	Dichtung	Sigillo	Joint	Sellar
11	Kama	Key	Passfeder	Chiavetta	Clavette	Clave
12	Segman (DIN 471)	Circlip (DIN 471)	Sicherungsring (DIN 471)	Anello di sicurezza (DIN 471)	Circlip (DIN 471)	Anillo de seguridad (DIN 471)
13	O-Ring	O-Ring	O-Ring	O-Ring	O-Ring	O-Ring
14	Rondela (7603)	Washer (7603)	Distanzscheibe (7603)	Rondella (7603)	Rondelle (7603)	El apoyo a disco (7603)
15	Yağ Tapası	Oil Plug	Ölstöpsel	Olio Tappo	Visde vidange	Tapón
16	Civata (DIN 912)	Bolt (DIN 912)	Verschrauben (DIN 912)	Bullone (DIN 912)	Boulonner (DIN 912)	Atornillar (DIN 912)

TR GENEL PARÇA LİSTESİ

EN GENERAL PART LIST

DE ALLGEMEINE TEILELISTE

IT GENERALE ELENCO DELLE PARTI

FR GÉNÉRALE LA LISTE DES PIÈCES

ES LISTE DE PIEZAS EN GENERAL

PAM B5 / 63 ... 225

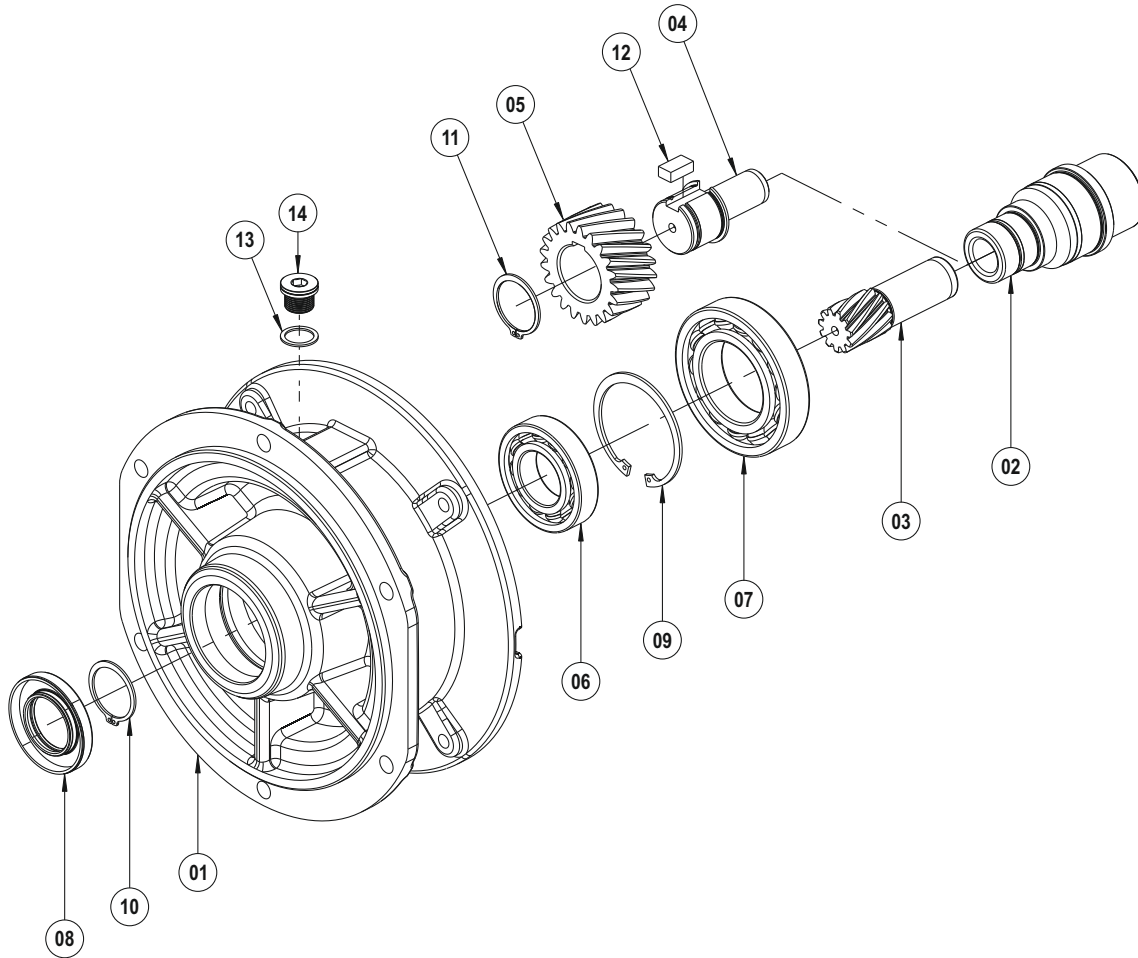

01	Gövde	Gear Case	Gehäuse	Ingranaggi Box	Carter d'engrenage	La caja de engranajes
02	PAM Mili	PAM Shaft	PAM Welle	PAM albero	PAM Arbre	PAM eje
03	Z1 Dişlisi	Driving Pinion	Antriebsritzel	Ingresso Pignone	Pignon d'entrée	Piñón de entrada
04	Pinyon Mili (Kamalı)	Pinion Shaft (With Key)	Ritzelwelle (Mit Passfeder)	Pignone (Con chiavetta)	Arbre Pignon (Avec clavette)	Eje del piñón (Con clave)
05	Z1 Dişlisi (Kamalı)	Driving Pinion (With Key)	Antriebsritzel (Mit Passfeder)	Ingresso Pignone (Con chiavetta)	Pignon d'entrée (Avec clavette)	Piñón de entrada (Con clave)
06	Rulman	Bearing	Kugellager	Cuscinetto	Roulement à billes	Rodamiento de bolas
07	Rulman	Bearing	Kugellager	Cuscinetto	Roulement à billes	Rodamiento de bolas
08	Yağ Keçesi	Oil Seal	Öldichtung	Paraolio	Bague d'etancheite	sello de aceite
09	Segman (DIN 472)	Circlip (DIN 472)	Sicherungsring (DIN 472)	Anello di sicurezza (DIN 472)	Circlip (DIN 472)	Anillo de seguridad (DIN 472)
10	Segman (DIN 471)	Circlip (DIN 471)	Sicherungsring (DIN 471)	Anello di sicurezza (DIN 471)	Circlip (DIN 471)	Anillo de seguridad (DIN 471)
11	Segman (DIN 471)	Circlip (DIN 471)	Sicherungsring (DIN 471)	Anello di sicurezza (DIN 471)	Circlip (DIN 471)	Anillo de seguridad (DIN 471)
12	Kama	Key	Passfeder	Chiavetta	Clavette	Clave
13	Rondela (DIN 7603)	Washer (DIN 7603)	Distanzscheibe (DIN 7603)	Rondella (DIN 7603)	Rondelle (DIN 7603)	El apoyo a disco (DIN 7603)
14	Yağ Tapası	Oil Plug	Ölstöpsel	Olio Tappo	Visde vidange	Tapón

TR GENEL PARÇA LİSTESİ

EN GENERAL PART LIST

DE ALLGEMEINE TEILELISTE

IT GENERALE ELENCO DELLE PARTI

FR GÉNÉRALE LA LISTE DES PIÈCES

ES LISTE DE PIEZAS EN GENERAL

**PAM B14 / 56 ... 90
(A / F / AF 202 ... 202G)**

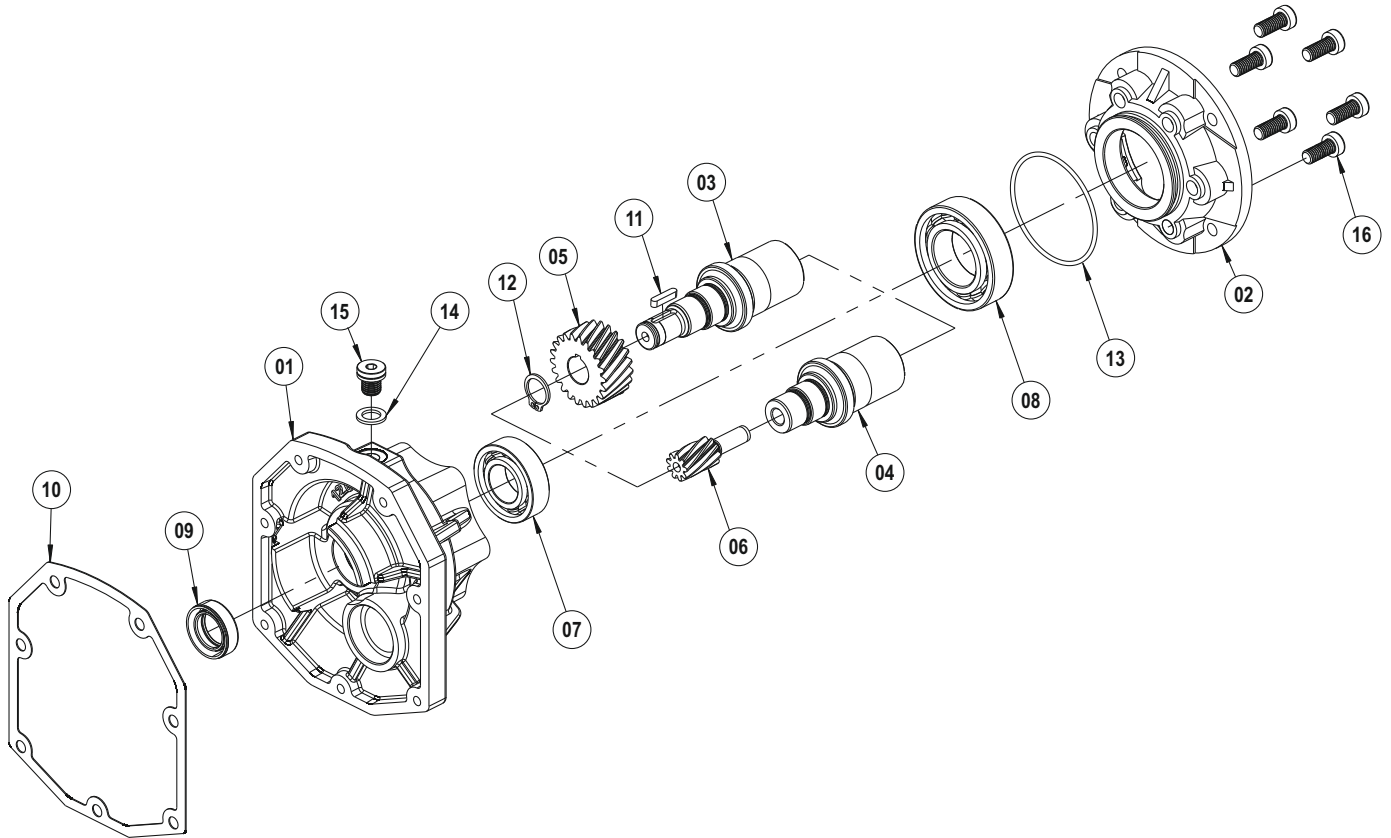

01	PAM Gövde	Gear Case	Gehäuse	Ingranaggi Box	Carter d'engrenage	La caja de engranajes
02	B14 Giriş Flanşı	Input Flange B14	Eingangsflansch B14	Flangia B14	B14 a bride	Brida B14
03	PAM Mili (kamalı)	PAM Shaft (With Key)	PAM Welle (Mit Passfeder)	PAM albero (Con chiavetta)	PAM Arbre (Avec clavette)	PAM eje (Con clave)
04	PAM Mili	PAM Shaft	PAM Welle	PAM albero	PAM Arbre	PAM eje
05	Z1 Dişlisi (kamalı)	Driving Pinion (With Key)	Antriebsritzel (Mit Passfeder)	Ingresso Pignone (Con chiavetta)	Pignon d'entrée (Avec clavette)	Piñón de entrada (Con clave)
06	Z1 Dişlisi	Driving Pinion	Antriebsritzel	Ingresso Pignone	Pignon d'entrée	Piñón de entrada
07	Rulman	Bearing	Kugellager	Cuscinetto	Roulement à billes	Rodamiento de bolas
08	Rulman	Bearing	Kugellager	Cuscinetto	Roulement à billes	Rodamiento de bolas
09	Yağ Keçesi	Oil Seal	Öldichtung	Paraolio	Bague d'etancheite	sello de aceite
10	Conta	Gasket	Dichtung	Sigillo	Joint	Sellar
11	Kama	Key	Passfeder	Chiavetta	Clavette	Clave
12	Segman (DIN 471)	Circlip (DIN 471)	Sicherungsring (DIN 471)	Anello di sicurezza (DIN 471)	Circlip (DIN 471)	Anillo de seguridad (DIN 471)
13	O-Ring	O-Ring	O-Ring	O-Ring	O-Ring	O-Ring
14	Rondela (7603)	Washer (7603)	Distanzscheibe (7603)	Rondella (7603)	Rondelle (7603)	El apoyo a disco (7603)
15	Yağ Tapası	Oil Plug	Ölstöpsel	Olio Tappo	Visde vidange	Tapón
16	Civata (DIN 912)	Bolt (DIN 912)	Verschrauben (DIN 912)	Bullone (DIN 912)	Boulonner (DIN 912)	Atornillar (DIN 912)

TR GENEL PARÇA LİSTESİ

EN GENERAL PART LIST

DE ALLGEMEINE TEILELISTE

IT GENERALE ELENCO DELLE PARTI

FR GÉNÉRALE LA LISTE DES PIÈCES

ES LISTE DE PIEZAS EN GENERAL

PAM B14 / 63 ... 132

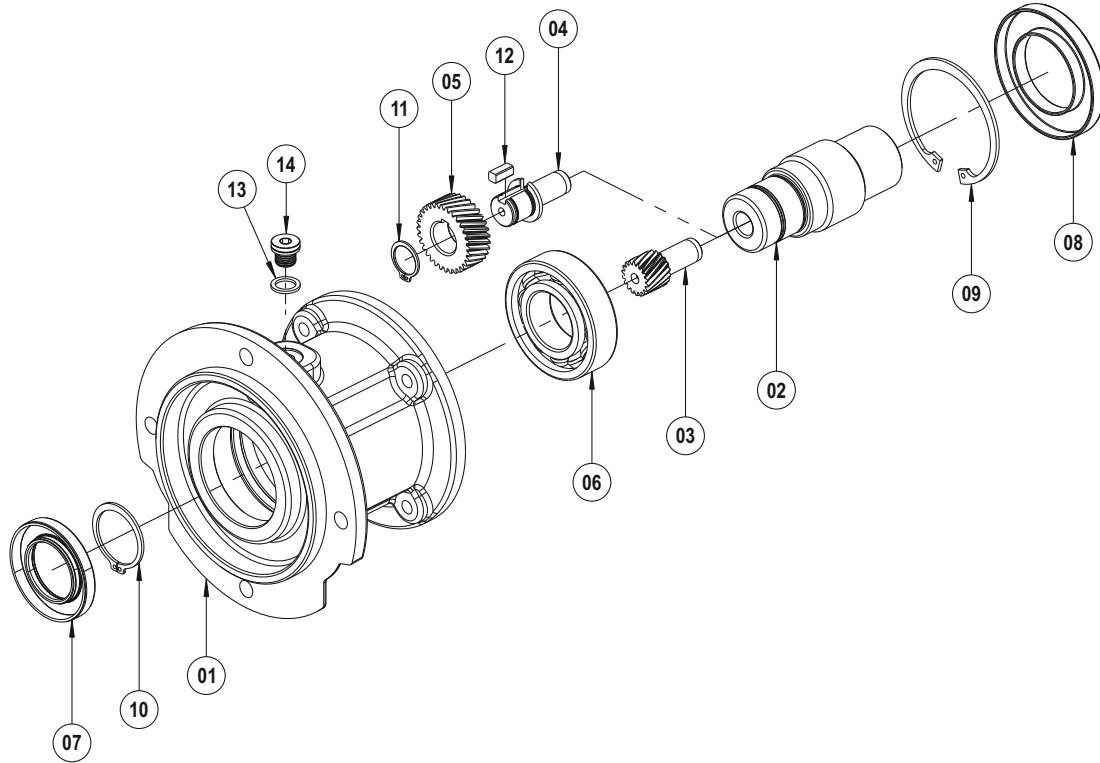

01	Gövde	Gear Case	Gehäuse	Ingranaggi Box	Carter d'engrenage	La caja de engranajes
02	PAM Mili	PAM Shaft	PAM Welle	PAM albero	PAM Arbre	PAM eje
03	Z1 Dişlisi	Driving Pinion	Antriebsritzel	Ingresso Pignone	Pignon d'entrée	Piñón de entrada
04	Pinyon Mili (Kamalı)	Pinion Shaft (With Key)	Ritzelwelle (Mit Passfeder)	Pignone (Con chiavetta)	Arbre Pignon (Avec clavette)	Eje del piñón (Con clave)
05	Z1 Dişlisi (Kamalı)	Driving Pinion (With Key)	Antriebsritzel (Mit Passfeder)	Ingresso Pignone (Con chiavetta)	Pignon d'entrée (Avec clavette)	Piñón de entrada (Con clave)
06	Rulman	Bearing	Kugellager	Cuscinetto	Roulement à billes	Rodamiento de bolas
07	Yağ Keçesi	Oil Seal	Öldichtung	Paraolio	Bague d'etancheite	sello de aceite
08	Yağ Keçesi	Oil Seal	Öldichtung	Paraolio	Bague d'etancheite	sello de aceite
09	Segman (DIN 472)	Circlip (DIN 472)	Sicherungsring (DIN 472)	Anello di sicurezza (DIN 472)	Circlip (DIN 472)	Anillo de seguridad (DIN 472)
10	Segman (DIN 471)	Circlip (DIN 471)	Sicherungsring (DIN 471)	Anello di sicurezza (DIN 471)	Circlip (DIN 471)	Anillo de seguridad (DIN 471)
11	Segman (DIN 471)	Circlip (DIN 471)	Sicherungsring (DIN 471)	Anello di sicurezza (DIN 471)	Circlip (DIN 471)	Anillo de seguridad (DIN 471)
12	Kama	Key	Passfeder	Chiavetta	Clavette	Clave
13	Rondela (DIN 7603)	Washer (DIN 7603)	Distanzscheibe (DIN 7603)	Rondella (DIN 7603)	Rondelle (DIN 7603)	El apoyo a disco (DIN 7603)
14	Yağ Tapası	Oil Plug	Ölstöpsel	Olio Tappo	Visde vidange	Tapón

TR GENEL PARÇA LİSTESİ

EN GENERAL PART LIST

DE ALLGEMEINE TEILELISTE

IT GENERALE ELENCO DELLE PARTI

FR GÉNÉRALE LA LISTE DES PIÈCES

ES LISTE DE PIEZAS EN GENERAL

W 140 - 173 - 207 - 250

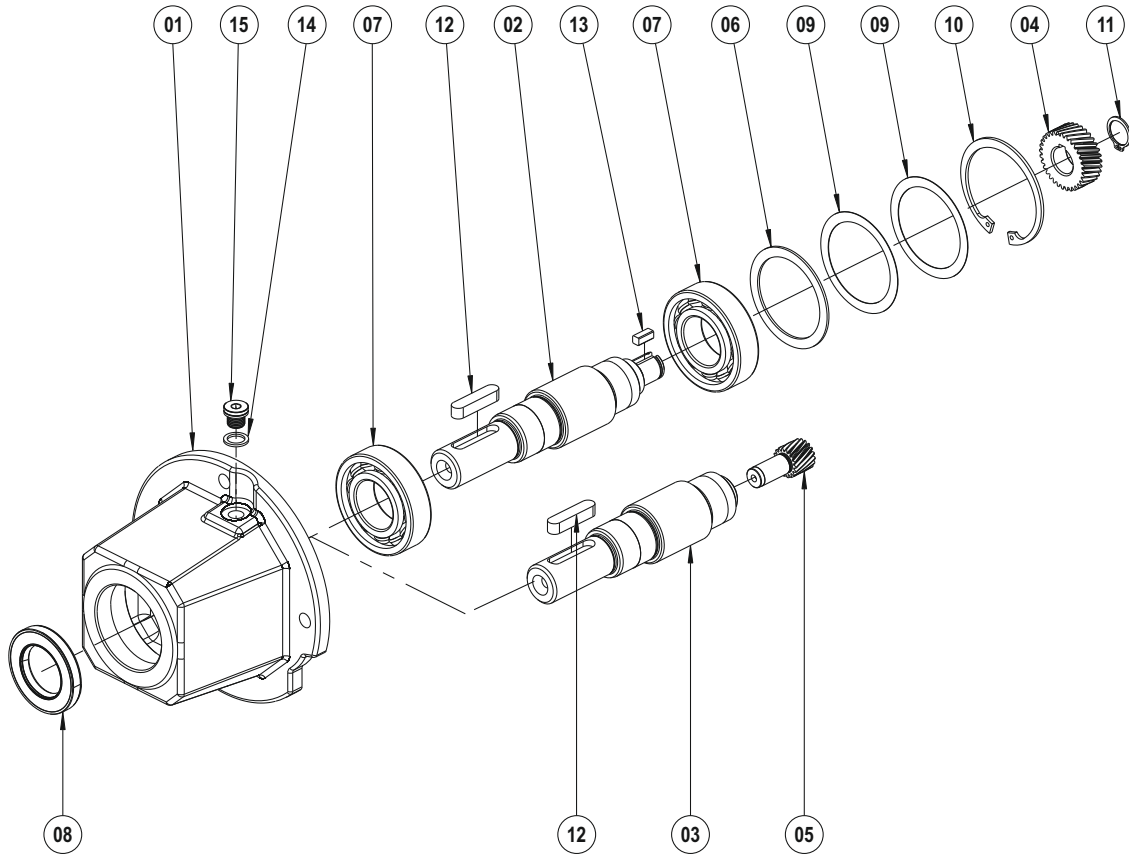

01	Gövde	Gear Case	Gehäuse	Ingranaggi Box	Carter d'engrenage	La caja de engranajes
02	W Mili (Kamalı)	W Shaft (With Key)	W Welle (Mit Passfeder)	W Albero (Con chiavetta)	W Arbre (Avec clavette)	W Eje (Con clave)
03	W Mili	W Shaft	W Welle	W Albero	W Arbre	W Eje
04	Z1 Dişlisi (Kamalı)	Driving Pinion (With Key)	Antriebsritzel (Mit Passfeder)	Ingresso Pignone (Con chiavetta)	Pignon d'entrée (Avec clavette)	Piñón de entrada (Con clave)
05	Z1 Dişlisi	Driving Pinion	Antriebsritzel	Ingresso Pignone	Pignon d'entrée	Piñón de entrada
06	Rondela	Washer	Distanzscheibe	Rondella	Rondelle	El apoyo a disco
07	Rulman	Bearing	Kugellager	Cuscinetto	Roulement à billes	Rodamiento de bolas
08	Yağ Keçesi	Oil Seal	Öldichtung	Paraolio	Bague d'étancheité	sello de aceite
09	Layner	Shim	Passscheibe	Shim	Rondelle d'ajustage	Calce
10	Segman (DIN 472)	Circlip (DIN 472)	Sicherungsring (DIN 472)	Anello di sicurezza (DIN 472)	Circlip (DIN 472)	Anillo de seguridad (DIN 472)
11	Segman (DIN 471)	Circlip (DIN 471)	Sicherungsring (DIN 471)	Anello di sicurezza (DIN 471)	Circlip (DIN 471)	Anillo de seguridad (DIN 471)
12	Kama	Key	Passfeder	Chiavetta	Clavette	Clave
13	Kama	Key	Passfeder	Chiavetta	Clavette	Clave
14	Rondela (DIN 7603)	Washer (DIN 7603)	Distanzscheibe (DIN 7603)	Rondella (DIN 7603)	Rondelle (DIN 7603)	El apoyo a disco (DIN 7603)
15	Yağ Tapası	Oil Plug	Ölstöpsel	Olio Tappo	Visde vidange	Tapón

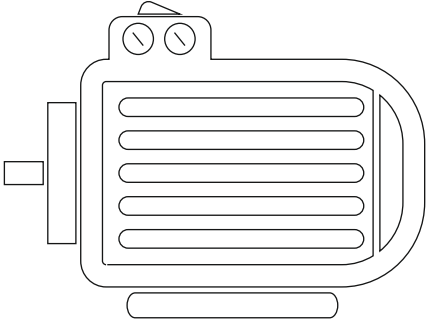

ÜÇ FAZLI MOTORLAR THREE PHASE MOTORS

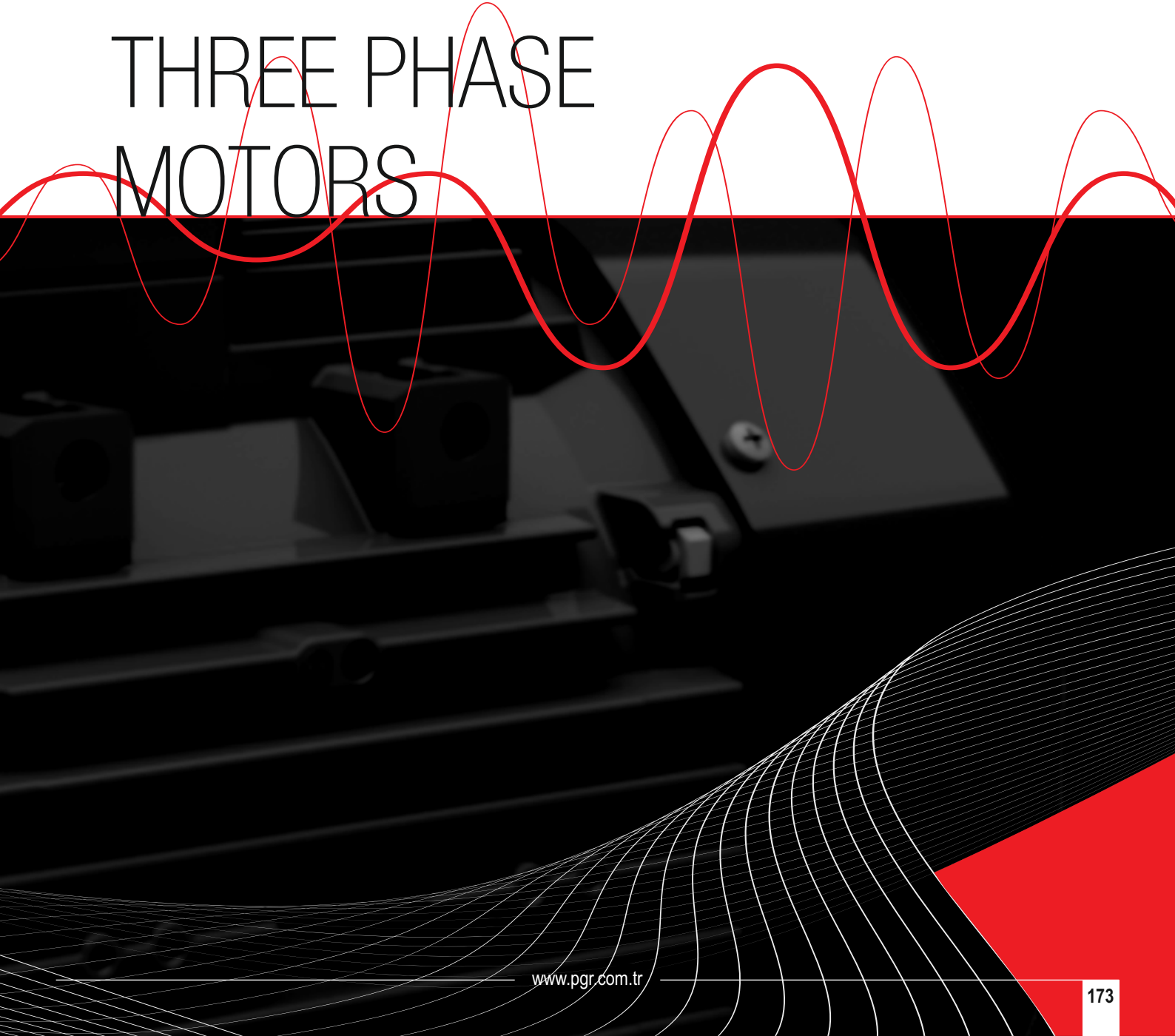

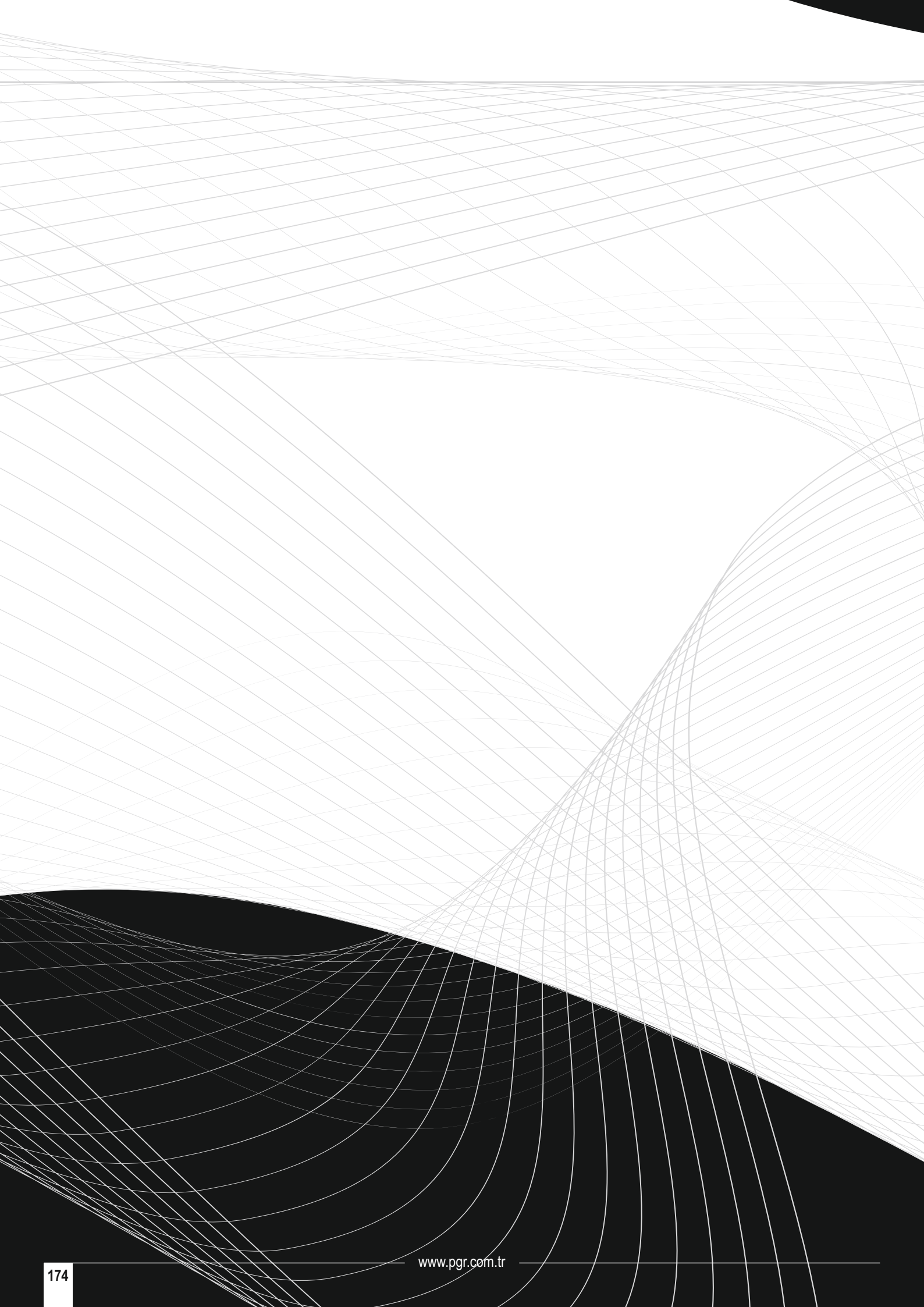

IE3

MOTOR TİPİ MOTOR TYPE	GÖVDE TİPİ HOUSING TYPE	NOMİNAL RATED VALUES						KALKIŞTAKİ DEĞERLER STARTING VALUES				Devrilme Momenti Oranı Breakdown Torque Ratio Mk/ Mn	VERİM* EFFICIENCY*			Cos φ	J	Ağırlık Weight (B3)	Ses Basınç Seviyesi Sound Pressure Level dBA **
		GÜÇ POWER		DEVİR SPEED	AKIM CURRENT	MOMENT TORQUE	AKIM CURRENT		MOMENT TORQUE		η%								
		kW	HP				rpm	A	Nm	I_A / I_N	$I_Δ / I_N$		M_A / M_N	$M_Δ / M_N$	4/4				
6 kutup 1000 d/dak / 6 pole 1000 rpm																			
230/400V	Q3H90L6C	Aluminium	0,75	1,0	950	2,1	7,6	4,9	-	2,5	-	3,0	78,9	78,4	74,9	0,67	0,00460	18	53
	Q3H90L6D	Aluminium	1,1	1,5	950	3,0	11,1	4,5	-	2,6	-	2,9	81,0	80,6	78,3	0,67	0,00528	20	53
	Q3H100L6D	Aluminium	1,5	2,0	960	4,1	14,9	4,8	-	2,6	-	3,0	82,5	81,7	78,2	0,65	0,01059	26	55
	Q3H112M6D	Aluminium	2,2	3,0	957	5,2	22,0	4,9	-	2,7	-	3,0	84,3	84,6	83,7	0,71	0,01383	32	57
400/690V	Q3H132S6A	Aluminium	3,0	4,0	978	7,3	29,3	1,9	5,7	0,6	2,0	2,5	85,6	85,2	82,8	0,68	0,03560	53	61
	Q3H132M6A	Aluminium	4,0	5,5	975	9,1	39,2	2,0	6,0	0,7	2,2	2,6	86,8	85,7	82,8	0,72	0,04030	58	60
	Q3H132M6B	Aluminium	5,5	7,5	971	12,0	54,1	2,1	6,3	0,7	2,1	2,6	88,0	87,6	85,3	0,75	0,05940	82	60
	Q3H160M6C	Aluminium	7,5	10,0	976	16,5	73,4	2,0	6,0	0,7	2,2	3,0	89,1	89,0	88,0	0,73	0,07540	88	62
	Q3H160L6D	Aluminium	11,0	15,0	974	24,2	107,8	2,1	6,3	0,7	2,2	3,0	90,3	90,1	89,3	0,73	0,09000	101	62
	Q3H180L6B	Aluminium	15,0	20,0	980	32,2	146,2	2,2	6,6	0,7	2,1	2,9	91,2	90,9	88,7	0,75	0,18660	155	68
	Q3H200L6C	Aluminium	18,5	25,0	981	40,3	180,1	2,3	6,9	0,6	1,9	2,7	91,7	91,6	91,3	0,72	0,23286	194	69
	Q3H200L6D	Aluminium	22,0	30,0	982	50,5	213,9	2,9	5,0	0,6	1,9	2,2	92,2	92,2	91,6	0,69	0,22166	193	69
	Q3E225M6C	Aluminium	30,0	40,0	975	59,1	293,8	1,9	6,1	0,6	1,8	2,5	92,9	92,8	91,8	0,80	0,52900	238	71

* IEC 60034-2-1'e göre / According to IEC 60034-2-1

** Ses Basınç Seviyeleri motordan 1m uzaklıktan ölçülmüştür. / The sound pressure measurements are taken 1m away from the motor

*** Tolerans +3 dBA / Tolerance +3 dBA

BOYUTLAR - B3 / DIMENSION - B3

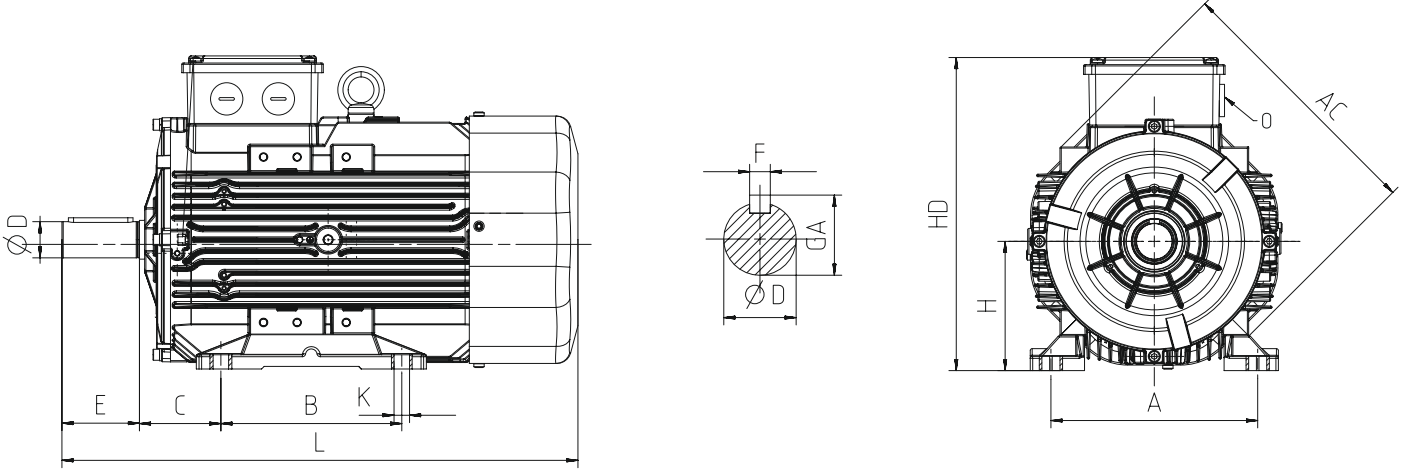

Güç Power (kW)	Kutup sayısı Number of Poles	Motor Tipi Motor Type	Gövde Tipi Housing Type	Ana Boyutlar Main Dimensions			Ayaklı Motorlar Foot Mounted Motors					Mil Shaft				Rulman Bearing		Keçe Seal		
				AC	L	O	B	A	H	HD	K	C	D ⁽¹⁾	E	GA	F ⁽²⁾	Kasnak Taraflı Drive Side	Kasnak Taraflı Aksı Non Drive Side	Kasnak Taraflı Drive Side	Kasnak Taraflı Aksı Non Drive Side
0,75	2	Q3H80M2C	Aluminium	158	268	1xM20	100	125	80	216	10	50	19	40	21,5	6	6204-ZZ	6204-ZZ	20*30*7	20*30*7
0,75	4	Q3H80M4D	Aluminium	158	268	1xM20	100	125	80	216	10	50	19	40	21,5	6	6204-ZZ	6204-ZZ	20*30*7	20*30*7
0,75	6	Q3H90L6C	Aluminium	172	344	1xM25	100-125	140	90	223	10	56	24	50	27,0	8	6305-ZZ	6205-ZZ	25*40*7	25*40*7
1,1	2	Q3H80M2D	Aluminium	158	268	1xM20	100	125	80	216	10	50	19	40	21,5	6	6204-ZZ	6204-ZZ	20*30*7	20*30*7
1,1	4	Q3H90L4C	Aluminium	158	303	1xM25	100-125	140	90	213	10	56	24	50	27,0	8	6305-ZZ	6204-ZZ	25*40*7	20*30*7
1,1	6	Q3H90L6D	Aluminium	172	344	1xM25	100-125	140	90	223	10	56	24	50	27,0	8	6305-ZZ	6205-ZZ	25*40*7	25*40*7
1,5	2	Q3H90L2C	Aluminium	158	303	1xM25	100-125	140	90	213	10	56	24	50	27,0	8	6305-ZZ	6204-ZZ	25*40*7	20*30*7
1,5	4	Q3H90L4D	Aluminium	172	344	1xM25	100-125	140	90	223	10	56	24	50	27,0	8	6305-ZZ	6205-ZZ	25*40*7	25*40*7
1,5	6	Q3H100L6D	Aluminium	191	400	1xM25	140	160	100	243	12	63	28	60	31,0	8	6306-ZZ	6205-ZZ	30*47*7	30*47*7
2,2	2	Q3H90L2D	Aluminium	172	344	1xM25	100-125	140	90	223	10	56	24	50	27,0	8	6305-ZZ	6205-ZZ	25*40*7	25*40*7
2,2	4	Q3H100L4C	Aluminium	172	384	1xM25	140	160	100	233	12	63	28	60	31,0	8	6306-ZZ	6205-ZZ	30*47*7	25*40*7
2,2	6	Q3H112M6D	Aluminium	210	396	1xM25	140	190	112	265	12	70	28	60	31,0	8	6306-ZZ	6206-ZZ	30*47*7	30*47*7
3	2	Q3H100L2D	Aluminium	172	349	1xM25	140	160	100	233	12	63	28	60	31,0	8	6306-ZZ	6205-ZZ	30*47*7	25*40*7
3	4	Q3H100L4D	Aluminium	191	400	1xM25	140	160	100	243	12	63	28	60	31,0	8	6306-ZZ	6205-ZZ	30*47*7	30*47*7
3	6	Q3H132S6A	Aluminium	260	481	1xM32	140-178	216	132	312	12	89	38	80	41,0	10	6208-ZZ	6208-ZZ	40*62*10	40*62*10
4	2	Q3H112M2C	Aluminium	191	400	1xM25	140	190	112	254	12	70	28	60	31,0	8	6306-ZZ	6205-ZZ	30*47*7	25*40*7
4	4	Q3H112M4D	Aluminium	210	396	1xM25	140	190	112	265	12	70	28	60	31,0	8	6306-ZZ	6206-ZZ	30*47*7	30*47*7
4	6	Q3H132M6A	Aluminium	260	481	1xM32	140-178	216	132	312	12	89	38	80	41,0	10	6208-ZZ	6208-ZZ	40*62*10	40*62*10
5,5	2	Q3H132S2C	Aluminium	210	422	1xM25	140-178	216	132	283	12	89	38	80	41,0	10	6208-ZZ	6206-ZZ	40*62*10	30*47*7
5,5	4	Q3H132S4B	Aluminium	260	481	1xM32	140-178	216	132	312	12	89	38	80	41,0	10	6208-ZZ	6208-ZZ	40*62*10	40*62*10
5,5	6	Q3H132M6B	Aluminium	260	481	1xM32	140-178	216	132	312	12	89	38	80	41,0	10	6208-ZZ	6208-ZZ	40*62*10	40*62*10
7,5	2	Q3H132S2D	Aluminium	210	448	1xM25	140-178	216	132	283	12	89	38	80	41,0	10	6208-ZZ	6206-ZZ	40*62*10	30*47*7
7,5	4	Q3H132M4D	Aluminium	260	481	1xM32	140-178	216	132	312	12	89	38	80	41,0	10	6208-ZZ	6208-ZZ	40*62*10	40*62*10
7,5	6	Q3H160M6C	Aluminium	305	591	1xM32	210-254	254	160	368	14,5	108	42	110	45,0	12	6309-ZZ	6209-ZZ	45*72*10	45*72*10
11	2	Q3H160M2C	Aluminium	260	520	1xM32	210-254	254	160	351	14,5	108	42	110	45,0	12	6309-ZZ	6208-ZZ	45*72*10	40*62*10
11	4	Q3H160M4C	Aluminium	260	578	1xM32	210-254	254	160	351	14,5	108	42	110	45,0	12	6309-ZZ	6208-ZZ	45*72*10	40*62*10
11	6	Q3H160L6D	Aluminium	305	591	1xM32	210-254	254	160	368	14,5	108	42	110	45,0	12	6309-ZZ	6209-ZZ	45*72*10	45*72*10
15	2	Q3H160M2DE	Aluminium	260	580	1xM32	210-254	254	160	351	14,5	108	42	110	45,0	12	6309-ZZ	6208-ZZ	45*72*10	40*62*10
15	4	Q3H160L4B	Aluminium	305	591	1xM32	210-254	254	160	368	14,5	108	42	110	45,0	12	6309-ZZ	6209-ZZ	45*72*10	45*72*10
15	6	Q3H180L6B	Aluminium	349	696	1xM40	241-279	279	180	437	14,5	121	48	110	51,5	14	6310-ZZ	6310-ZZ	50*80*10	50*80*10

(1) Toleranslar 28 mm'ye kadar DIN EN 50347 "j6", 28 mm ve üzeri "k6" / Tolerance DIN EN 50347 "j6" up to 28mm, "k6" above 28mm
(2) DIN 6885'e göre / According to DIN 6885

Güç Power (kW)	Kutup sayısı Number of Poles	Motor Tipi Motor Type	Gövde Tipi Housing Type	Ana Boyutlar Main Dimensions			Ayaklı Motorlar Foot Mounted Motors						Mil Shaft				Rulman Bearing		Keçe Seal	
				AC	L	O	B	A	H	HD	K	C	D ⁽¹⁾	E	GA	F ⁽²⁾	Kasnak Tarafı Drive Side	Kasnak Tarafı Aksi Non drive Side	Kasnak Tarafı Drive Side	Kasnak Tarafı Aksi Non drive Side
18,5	2	Q3H160L2C	Aluminium	305	591	1xM32	210-254	254	160	368	14,5	108	42	110	45,0	12	6309-ZZ	6209-ZZ	45*72*10	45*72*10
18,5	4	Q3H180M4B	Aluminium	305	596	1xM32	241-279	279	180	398	14,5	121	48	110	51,5	14	6310-ZZ	6209-ZZ	50*80*10	45*72*10
18,5	6	Q3H200L6C	Aluminium	349	750	1xM50	305	318	200	455	18,5	133	55	110	59,0	16	6312-ZZ	6310-ZZ	60*90*10	60*90*10
22	2	Q3H180M2B	Aluminium	305	596	1xM32	241-279	279	180	398	14,5	121	48	110	51,5	14	6310-ZZ	6209-ZZ	50*80*10	45*72*10
22	4	Q3H180L4B	Aluminium	349	696	1xM40	241-279	279	180	437	14,5	121	48	110	51,5	14	6310-ZZ	6310-ZZ	50*80*10	50*80*10
22	6	Q3H200L6D	Aluminium	349	759	1xM50	267-305	318	200	455	18,5	133	55	110	59,0	16	6312-ZZ	6310-ZZ	60*90*10	60*90*10
30	2	Q3H200L2C	Aluminium	349	706	1xM50	267-305	318	200	455	18,5	133	55	110	59,0	16	6312-ZZ	6310-ZZ	60*90*10	60*90*10
30	4	Q3H200L4D	Aluminium	349	759	1xM50	267-305	318	200	455	18,5	133	55	110	59,0	16	6312-ZZ	6310-ZZ	60*90*10	60*90*10
30	6	Q3E225M6C	Aluminium	456	765	1xM50	286-311	356	225	485	18,5	149	60	140	64,0	18	6313-ZZ	6313-ZZ	65*100*13	65*100*13
37	2	Q3H200L2D	Aluminium	349	706	1xM50	305	318	200	455	18,5	133	55	110	59,0	16	6312-ZZ	6310-ZZ	60*90*10	60*90*10
37	4	Q3E225M4B	Aluminium	456	765	1xM50	286-311	356	225	485	18,5	149	60	140	64,0	18	6313-ZZ	6313-ZZ	65*100*13	65*100*13
45	2	Q3E225M2B	Aluminium	456	735	1xM50	286-311	356	225	485	18,5	149	55	110	59,0	16	6313-ZZ	6313-ZZ	65*100*13	65*100*13
45	4	Q3E225M4C	Aluminium	456	765	1xM50	286-311	356	225	485	18,5	149	60	140	64,0	18	6313-ZZ	6313-ZZ	65*100*13	65*100*13
55	2	Q3E250M2A	Aluminium	527	886	2xM50	349	406	250	615	24	149	60	140	64,0	18	6315-ZZ	6313-ZZ	75*112*12	65*100*13
55	2	Q3EP250M2C	Cast Iron	489	893	1xM50	349	406	250	616	24	149	60	140	69,0	18	6316	6316	80*100*10	80*100*10
55	4	Q3E250M4B	Cast Iron	489	893	1xM50	349	406	250	616	24	149	65	140	69,0	18	6316	6316	80*100*10	80*100*10
75	2	Q3EP280M2C	Cast Iron	489	1025	1xM50	419	457	280	647	24	190	65	140	69,0	18	6316	6316	80*100*10	80*100*10
75	4	Q3EP280M4C	Cast Iron	489	1025	1xM50	419	457	280	647	24	190	75	140	79,5	20	6316	6316	80*100*10	80*100*10
90	2	Q3EP280M2D	Cast Iron	489	1025	1xM50	419	457	280	647	24	190	65	140	69,0	18	6316	6316	80*100*10	80*100*10
90	4	Q3EP280M4D	Cast Iron	489	1025	1xM50	419	457	280	647	24	190	75	140	79,5	20	6316	6316	80*100*10	80*100*10
110	2	Q3EP315S2C	Cast Iron	652	1176	2xM63	406	508	315	833	28	216	65	140	69	18	6316	6316	80*100*5.5	80*100*5.5
110	4	Q3EP315S4C	Cast Iron	652	1206	2xM63	406	508	315	833	28	216	80	170	85	22	6319	6319	95*115*5.5	95*115*5.5
132	2	Q3EP315M2B	Cast Iron	652	1176	2xM63	457	508	315	833	28	216	65	140	69	18	6316	6316	80*100*5.5	80*100*5.5
132	4	Q3EP315M4B	Cast Iron	652	1206	2xM63	457	508	315	833	28	216	80	170	85	22	6319	6319	95*115*5.5	95*115*5.5
160	2	Q3EP315L2A	Cast Iron	652	1287	2xM63	508	508	315	833	28	216	65	140	69	18	6316	6316	80*100*5.5	80*100*5.5
160	4	Q3EP315L4A	Cast Iron	652	1317	2xM63	508	508	315	833	28	216	80	170	85	22	6319	6319	95*115*5.5	95*115*5.5
200	2	Q3EP315L2C	Cast Iron	652	1287	2xM63	508	508	315	833	28	216	65	140	69	18	6316	6316	80*100*5.5	80*100*5.5
200	4	Q3EP315L4C	Cast Iron	652	1317	2xM63	508	508	315	833	28	216	80	170	85	22	6319	6319	95*115*5.5	95*115*5.5
250	2	Q3EP355M2C	Cast Iron	762	1512	4xM63	560	610	355	997	28	254	75	140	80	20	6317	6317	85*105*5.5	85*105*5.5
250	4	Q3EP355M4C	Cast Iron	762	1542	4xM63	560	610	355	997	28	254	95	170	100	25	6322	6322	110*130*5.5	110*130*5.5
315	2	Q3EP355L2B	Cast Iron	762	1512	4xM63	630	610	355	997	28	254	75	140	80	20	6317	6317	85*105*5.5	85*105*5.5
315	4	Q3EP355L4B	Cast Iron	762	1542	4xM63	630	610	355	997	28	254	95	170	100	25	6322	6322	110*130*5.5	110*130*5.5
355	2	Q3EP355L2C	Cast Iron	762	1512	4xM63	630	610	355	997	28	254	75	140	80	20	6317	6317	85*105*5.5	85*105*5.5
355	4	Q3EP355L4C	Cast Iron	762	1542	4xM63	630	610	355	997	28	254	95	170	100	25	6322	6322	110*130*5.5	110*130*5.5

(1) Toleranslar 28 mm'ye kadar DIN EN 50347 "j6", 28 mm ve üzeri "k6" / Tolerance DIN EN 50347 "j6" up to 28mm, "k6" above 28mm
(2) DIN 6885'e göre / According to DIN 6885

BOYUTLAR - B5, B35 / DIMENSION - B5, B35

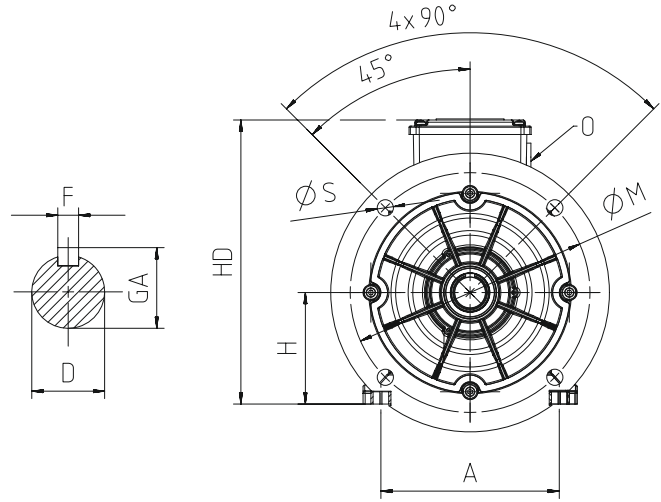
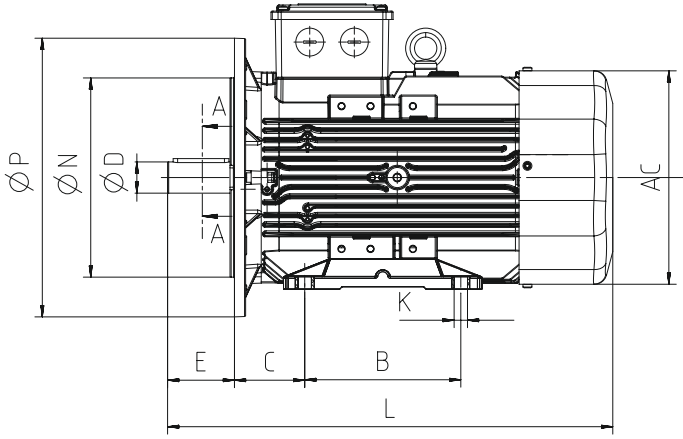

Güç Power (kW)	Kutup sayısı Number of Poles	Motor Tipi Motor Type	Gövde Tipi Housing Type	Ana Boyutlar Main Dimensions			Ayaklı Motorlar Foot Mounted Motors					Mil Shaft		Rulman Bearing		Keçe Seal		Flanş (FA) (B5) Flange (FA) (B5)						
				AC	L	O	B	A	H	HD	K	D ⁽¹⁾	E	GA	F ⁽²⁾	Kasnak Taraflı Drive Side	Kasnak Taraflı Non drive Side	Kasnak Taraflı Drive Side	Kasnak Taraflı Non drive Side	P	N ⁽³⁾	M	R	S
0,75	2	Q3H80M2C	Aluminium	158	268	1xM20	100	125	80	216	10	19	40	21,5	6	6204-ZZ	6204-ZZ	20*30*7	20*30*7	200	130	165	-	12
0,75	4	Q3H80M4D	Aluminium	158	268	1xM20	100	125	80	216	10	19	40	21,5	6	6204-ZZ	6204-ZZ	20*30*7	20*30*7	200	130	165	-	12
0,75	6	Q3H90L6C	Aluminium	172	344	1xM25	100-125	140	90	223	10	24	50	27,0	8	6305-ZZ	6205-ZZ	25*40*7	25*40*7	200	130	165	-	12
1,1	2	Q3H80M2D	Aluminium	158	268	1xM20	100	125	80	216	10	19	40	21,5	6	6204-ZZ	6204-ZZ	20*30*7	20*30*7	200	130	165	-	12
1,1	4	Q3H90L4C	Aluminium	158	303	1xM25	100-125	140	90	213	10	24	50	27,0	8	6305-ZZ	6204-ZZ	25*40*7	20*30*7	200	130	165	-	12
1,1	6	Q3H90L6D	Aluminium	172	344	1xM25	100-125	140	90	223	10	24	50	27,0	8	6305-ZZ	6205-ZZ	25*40*7	25*40*7	200	130	165	-	12
1,5	2	Q3H90L2C	Aluminium	158	303	1xM25	100-125	140	90	213	10	24	50	27,0	8	6305-ZZ	6204-ZZ	25*40*7	20*30*7	200	130	165	-	12
1,5	4	Q3H90L4D	Aluminium	172	344	1xM25	100-125	140	90	223	10	24	50	27,0	8	6305-ZZ	6205-ZZ	25*40*7	25*40*7	200	130	165	-	12
1,5	6	Q3H100L6D	Aluminium	191	400	1xM25	140	160	100	243	12	28	60	31,0	8	6306-ZZ	6205-ZZ	30*47*7	30*47*7	250	180	215	-	14,5
2,2	2	Q3H90L2D	Aluminium	172	344	1xM25	100-125	140	90	223	10	24	50	27,0	8	6305-ZZ	6205-ZZ	25*40*7	25*40*7	200	130	165	-	12
2,2	4	Q3H100L4C	Aluminium	172	384	1xM25	140	160	100	233	12	28	60	31,0	8	6306-ZZ	6205-ZZ	30*47*7	25*40*7	250	180	215	-	14,5
2,2	6	Q3H112M6D	Aluminium	210	396	1xM25	140	190	112	265	12	28	60	31,0	8	6306-ZZ	6206-ZZ	30*47*7	30*47*7	250	180	215	-	14,5
3	2	Q3H100L2D	Aluminium	172	349	1xM25	140	160	100	233	12	28	60	31,0	8	6306-ZZ	6205-ZZ	30*47*7	25*40*7	250	180	215	-	14,5
3	4	Q3H100L4D	Aluminium	191	400	1xM25	140	160	100	243	12	28	60	31,0	8	6306-ZZ	6205-ZZ	30*47*7	30*47*7	250	180	215	-	14,5
3	6	Q3H132S6A	Aluminium	260	481	1xM32	140-178	216	132	312	12	38	80	41,0	10	6208-ZZ	6208-ZZ	40*62*10	40*62*10	300	230	265	-	14,5
4	2	Q3H112M2C	Aluminium	191	399	1xM25	140	190	112	254	12	28	60	31,0	8	6306-ZZ	6205-ZZ	30*47*7	25*40*7	250	180	215	-	14,5
4	4	Q3H112M4D	Aluminium	210	396	1xM25	140	190	112	265	12	28	60	31,0	8	6306-ZZ	6206-ZZ	30*47*7	30*47*7	250	180	215	-	14,5
4	6	Q3H132M6A	Aluminium	260	481	1xM32	140-178	216	132	312	12	38	80	41,0	10	6208-ZZ	6208-ZZ	40*62*10	40*62*10	300	230	265	-	14,5
5,5	2	Q3H132S2C	Aluminium	210	422	1xM25	140-178	216	132	283	12	38	80	41,0	10	6208-ZZ	6206-ZZ	40*62*10	30*47*7	300	230	265	-	14,5
5,5	4	Q3H132S4B	Aluminium	260	481	1xM32	140-178	216	132	312	12	38	80	41,0	10	6208-ZZ	6208-ZZ	40*62*10	40*62*10	300	230	265	-	14,5
5,5	6	Q3H132M6B	Aluminium	260	481	1xM32	140-178	216	132	312	12	38	80	41,0	10	6208-ZZ	6208-ZZ	40*62*10	40*62*10	300	230	265	-	14,5
7,5	2	Q3H132S2D	Aluminium	210	448	1xM25	140-178	216	132	283	12	38	80	41,0	10	6208-ZZ	6206-ZZ	40*62*10	30*47*7	300	230	265	-	14,5
7,5	4	Q3H132M4D	Aluminium	260	481	1xM32	140-178	216	132	312	12	38	80	41,0	10	6208-ZZ	6208-ZZ	40*62*10	40*62*10	300	230	265	-	14,5
7,5	6	Q3H160M6C	Aluminium	305	591	1xM32	210-254	254	160	368	14,5	42	110	45,0	12	6309-ZZ	6209-ZZ	45*72*10	45*72*10	350	250	300	-	18,5
11	2	Q3H160M2C	Aluminium	260	520	1xM32	210-254	254	160	351	14,5	42	110	45,0	12	6309-ZZ	6208-ZZ	45*72*10	40*62*10	350	250	300	-	18,5
11	4	Q3H160M4C	Aluminium	260	580	1xM32	210-254	254	160	351	14,5	42	110	45,0	12	6309-ZZ	6208-ZZ	45*72*10	40*62*10	350	250	300	-	18,5
11	6	Q3H160L6D	Aluminium	305	591	1xM32	210-254	254	160	368	14,5	42	110	45,0	12	6309-ZZ	6209-ZZ	45*72*10	45*72*10	350	250	300	-	18,5
15	2	Q3H160M2DE	Aluminium	260	580	1xM32	210-254	254	160	351	14,5	42	110	45,0	12	6309-ZZ	6208-ZZ	45*72*10	40*62*10	350	250	300	-	18,5
15	4	Q3H160L4B	Aluminium	305	591	1xM32	210-254	254	160	368	14,5	42	110	45,0	12	6309-ZZ	6209-ZZ	45*72*10	45*72*10	350	250	300	-	18,5
15	6	Q3H180L6B	Aluminium	349	696	1xM40	241-279	279	180	437	14,5	48	110	51,5	14	6310-ZZ	6310-ZZ	50*80*10	50*80*10	350	250	300	-	18,5

(1) Toleranslar 28 mm'ye kadar DIN EN 50347 "j6", 28 mm ve üzeri "k6" / Tolerance DIN EN 50347 "j6" up to 28mm, "k6" above 28mm

(2) DIN 6885'e göre / According to DIN 6885

(3) Tolerans DIN EN 50347 "j6" / Tolerance DIN EN 50347 "j6"

Güç Power (kW)	Kutup sayısı Number of Poles	Motor Tipi Motor Type	Gövde Tipi Housing Type	Ana Boyutlar Main Dimensions			Ayaklı Motorlar Foot Mounted Motors					Mil Shaft				Rulman Bearing		Keçe Seal		Flanş (FA) (B5) Flange (FA) (B5)				
				AC	L	O	B	A	H	HD	K	D ⁽¹⁾	E	GA	F ⁽²⁾	Kasnak Taraflı Drive Side	Kasnak Taraflı Aksli Non drive Side	Kasnak Taraflı Drive Side	Kasnak Taraflı Aksli Non drive Side	P	N ⁽³⁾	M	R	S
18,5	4	Q3H180M4B	Aluminium	305	596	1xM32	241-279	279	180	398	14,5	48	110	51,5	14	6310-ZZ	6209-ZZ	50*80*10	45*72*10	350	250	300	-	18,5
18,5	6	Q3H200L6C	Aluminium	349	750	1xM50	305	318	200	455	18,5	55	110	59,0	16	6312-ZZ	6310-ZZ	60*90*10	60*90*10	400	300	350	-	18,5
22	2	Q3H180M2A	Aluminium	305	596	1xM32	241-279	279	180	398	14,5	48	110	51,5	14	6310-ZZ	6209-ZZ	50*80*10	45*72*10	350	250	300	-	18,5
22	4	Q3H180L4B	Aluminium	349	696	1xM40	241-279	279	180	437	14,5	48	110	51,5	14	6310-ZZ	6310-ZZ	50*80*10	50*80*10	350	250	300	-	18,5
22	6	Q3H200L6D	Aluminium	349	759	1xM50	305	318	200	455	18,5	55	110	59,0	16	6312-ZZ	6310-ZZ	60*90*10	60*90*10	400	300	350	-	18,5
30	2	Q3H200L2C	Aluminium	349	706	1xM50	305	318	200	455	18,5	55	110	59,0	16	6312-ZZ	6310-ZZ	60*90*10	60*90*10	400	300	350	-	18,5
30	4	Q3H200L4D	Aluminium	349	759	1xM50	305	318	200	455	18,5	55	110	59,0	16	6312-ZZ	6310-ZZ	60*90*10	60*90*10	400	300	350	-	18,5
30	6	Q3E225M6C	Aluminium	456	765	1xM50	286-311	356	225	485	18,5	60	140	64,0	18	6313-ZZ	6313-ZZ	65*100*13	65*100*13	450	350	400	-	18,5
37	2	Q3H200L2D	Aluminium	349	706	1xM50	305	318	200	455	18,5	55	110	59,0	16	6312-ZZ	6310-ZZ	60*90*10	60*90*10	400	300	350	-	18,5
37	4	Q3E225M4B	Aluminium	456	765	1xM50	286-311	356	225	485	18,5	60	140	64,0	18	6313-ZZ	6313-ZZ	65*100*13	65*100*13	450	350	400	-	18,5
45	2	Q3E225M2B	Aluminium	456	735	1xM50	286-311	356	225	485	18,5	55	110	59,0	16	6313-ZZ	6313-ZZ	65*100*13	65*100*13	450	350	400	-	18,5
45	4	Q3E225M4C	Aluminium	456	765	1xM50	286-311	356	225	485	18,5	60	140	64,0	18	6313-ZZ	6313-ZZ	65*100*13	65*100*13	450	350	400	-	18,5
55	2	Q3E250M2A	Aluminium	527	886	2*M50	349	406	250	615	24	60	140	64,0	18	6315-ZZ	6313-ZZ	75*112*12	65*100*13	550	450	500	-	18,5
55	2	Q3EP250M2C	Cast Iron	489	893	1xM50	349	406	250	616	24	60	140	69,0	18	6316	6316	80*100*10	80*100*10	550	450	500	-	18,5
55	4	Q3E250M4B	Cast Iron	489	893	1xM50	349	406	250	616	24	65	140	69,0	18	6316	6316	80*100*10	80*100*10	550	450	500	-	18,5
75	2	Q3EP280M2C	Cast Iron	489	1025	1xM50	368-419	457	280	647	24	65	140	69,0	18	6316	6316	80*100*10	80*100*10	550	450	500	-	18,5
75	4	Q3EP280M4C	Cast Iron	489	1025	1xM50	368-419	457	280	647	24	75	140	79,5	20	6316	6316	80*100*10	80*100*10	550	450	500	-	18,5
90	2	Q3EP280M2D	Cast Iron	489	1025	1xM50	368-419	457	280	647	24	65	140	69,0	18	6316	6316	80*100*10	80*100*10	550	450	500	-	18,5
90	4	Q3EP280M4D	Cast Iron	489	1025	1xM50	368-419	457	280	647	24	75	140	79,5	20	6316	6316	80*100*10	80*100*10	550	450	500	-	18,5
110	2	Q3EP315S2C	Cast Iron	652	1176	2*M63	406	508	315	833	28	65	140	69	18	6316	6316	80*100*5,5	80*100*5,5	660	550	600	0	24
110	4	Q3EP315S4C	Cast Iron	652	1206	2*M63	406	508	315	833	28	80	170	85	22	6319	6319	95*115*5,5	95*115*5,5	660	550	600	0	24
132	2	Q3EP315M2B	Cast Iron	652	1176	2*M63	457	508	315	833	28	65	140	69	18	6316	6316	80*100*5,5	80*100*5,5	660	550	600	0	24
132	4	Q3EP315M4B	Cast Iron	652	1206	2*M63	457	508	315	833	28	80	170	85	22	6319	6319	95*115*5,5	95*115*5,5	660	550	600	0	24
160	2	Q3EP315L2A	Cast Iron	652	1287	2*M63	508	508	315	833	28	65	140	69	18	6316	6316	80*100*5,5	80*100*5,5	660	550	600	0	24
160	4	Q3EP315L4A	Cast Iron	652	1317	2*M63	508	508	315	833	28	80	170	85	22	6319	6319	95*115*5,5	95*115*5,5	660	550	600	0	24
200	2	Q3EP315L2C	Cast Iron	652	1287	2*M63	508	508	315	833	28	65	140	69	18	6316	6316	80*100*5,5	80*100*5,5	660	550	600	0	24
200	4	Q3EP315L4C	Cast Iron	652	1317	2*M63	508	508	315	833	28	80	170	85	22	6319	6319	95*115*5,5	95*115*5,5	660	550	600	0	24
250	2	Q3EP355M2C	Cast Iron	762	1512	4*M63	560	610	355	997	28	75	140	80	20	6317	6317	85*105*5,5	85*105*5,5	800	680	740	0	24
250	4	Q3EP355M4C	Cast Iron	762	1542	4*M63	560	610	355	997	28	95	170	100	25	6322	6322	110*130*5,5	110*130*5,5	800	680	740	0	24
315	2	Q3EP355L2B	Cast Iron	762	1512	4*M63	630	610	355	997	28	75	140	80	20	6317	6317	85*105*5,5	85*105*5,5	800	680	740	0	24
315	4	Q3EP355L4B	Cast Iron	762	1542	4*M63	630	610	355	997	28	95	170	100	25	6322	6322	110*130*5,5	110*130*5,5	800	680	740	0	24
355	2	Q3EP355L2C	Cast Iron	762	1512	4*M63	630	610	355	997	28	75	140	80	20	6317	6317	85*105*5,5	85*105*5,5	800	680	740	0	24
355	4	Q3EP355L4C	Cast Iron	762	1542	4*M63	630	610	355	997	28	95	170	100	25	6322	6322	110*130*5,5	110*130*5,5	800	680	740	0	24

(1) Toleranslar 28 mm'ye kadar DIN EN 50347 "j6", 28 mm ve üzeri "k6" / Tolerance DIN EN 50347 "j6" up to 28mm, "k6" above 28mm

(2) DIN 6885'e göre / According to DIN 6885

(3) Tolerans DIN EN 50347 "j6" / Tolerance DIN EN 50347 "j6"

BOYUTLAR - B14a, B34a / DIMENSION - B14a, B34a

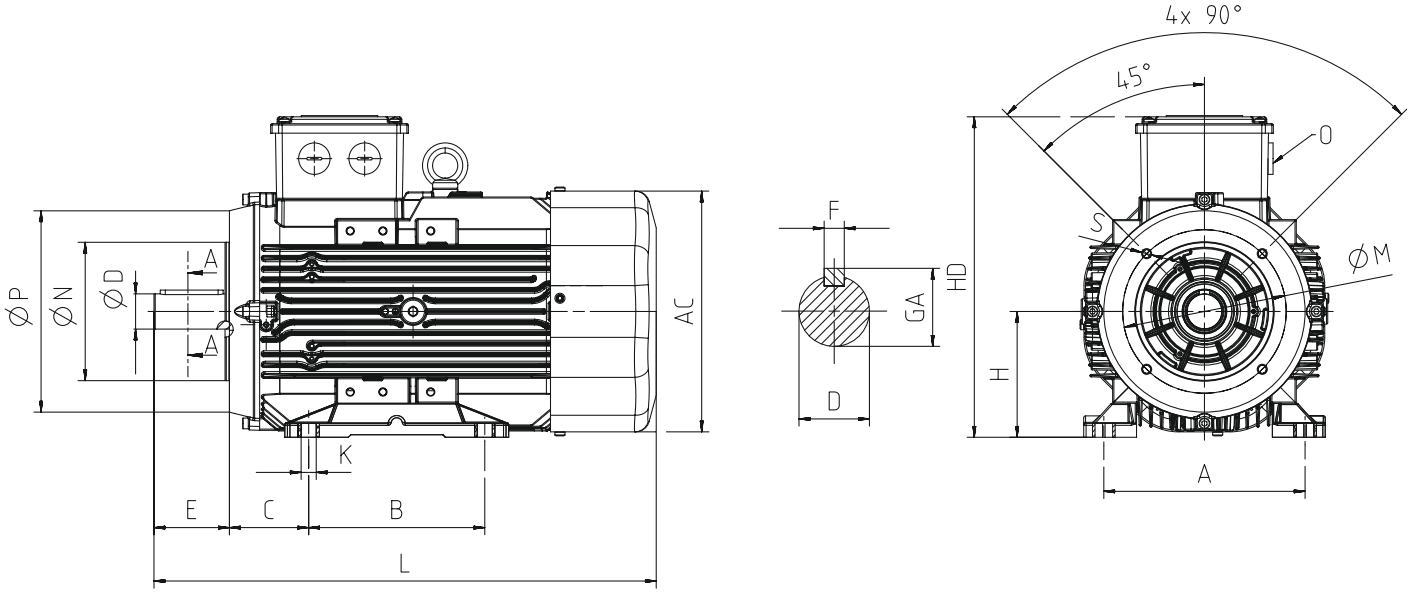

Güç Power (kW)	Kutup sayısı Number of Poles	Motor Tipi Motor Type	Gövde Tipi Housing Type	Ana Boyutlar Main Dimensions			Ayaklı Motorlar Foot Mounted Motors				Mil Shaft		Rulman Bearing		Keçe Seal		Flanş (FC) (B14a) Flange (FC) (B14a)							
				AC	L	O	B	A	H	HD	K	D ⁽¹⁾	E	GA	F ⁽²⁾	Kasnak Taraflı Drive Side	Kasnak Taraflı Aksli Non drive Side	Kasnak Taraflı Drive Side	Kasnak Taraflı Aksli Non drive Side	P	N ⁽³⁾	M	R	S
0,75	2	Q3H80M2C	Aluminium	158	268	1xM20	100	125	80	216	10	19	40	21,5	6	6204-ZZ	6204-ZZ	20*30*7	20*30*7	120	80	100	-	M6
0,75	4	Q3H80M4D	Aluminium	158	268	1xM20	100	125	80	216	10	19	40	21,5	6	6204-ZZ	6204-ZZ	20*30*7	20*30*7	120	80	100	-	M6
0,75	6	Q3H90L6C	Aluminium	172	344	1xM25	100-125	140	90	223	10	24	50	27,0	8	6305-ZZ	6205-ZZ	25*40*7	25*40*7	140	95	115	-	M8
1,1	2	Q3H80M2D	Aluminium	158	268	1xM20	100	125	80	216	10	19	40	21,5	6	6204-ZZ	6204-ZZ	20*30*7	20*30*7	120	80	100	-	M6
1,1	4	Q3H90L4C	Aluminium	158	303	1xM25	100-125	140	90	213	10	24	50	27,0	8	6305-ZZ	6204-ZZ	25*40*7	20*30*7	140	95	115	-	M8
1,1	6	Q3H90L6D	Aluminium	172	344	1xM25	100-125	140	90	223	10	24	50	27,0	8	6305-ZZ	6205-ZZ	25*40*7	25*40*7	140	95	115	-	M8
1,5	2	Q3H90L2C	Aluminium	158	303	1xM25	100-125	140	90	213	10	24	50	27,0	8	6305-ZZ	6204-ZZ	25*40*7	20*30*7	140	95	115	-	M8
1,5	4	Q3H90L4D	Aluminium	172	344	1xM25	100-125	140	90	223	10	24	50	27,0	8	6305-ZZ	6205-ZZ	25*40*7	25*40*7	140	95	115	-	M8
1,5	6	Q3H100L6D	Aluminium	191	400	1xM25	140	160	100	243	12	28	60	31,0	8	6306-ZZ	6205-ZZ	30*47*7	30*47*7	160	110	130	-	M8
2,2	2	Q3H90L2D	Aluminium	172	344	1xM25	100-125	140	90	223	10	24	50	27,0	8	6305-ZZ	6205-ZZ	25*40*7	25*40*7	140	95	115	-	M8
2,2	4	Q3H100L4C	Aluminium	172	384	1xM25	140	160	100	233	12	28	60	31,0	8	6306-ZZ	6205-ZZ	30*47*7	25*40*7	160	110	130	-	M8
2,2	6	Q3H112M6D	Aluminium	210	396	1xM25	140	190	112	265	12	28	60	31,0	8	6306-ZZ	6206-ZZ	30*47*7	30*47*7	160	110	130	-	M8
3	2	Q3H100L2D	Aluminium	172	349	1xM25	140	160	100	233	12	28	60	31,0	8	6306-ZZ	6205-ZZ	30*47*7	25*40*7	160	110	130	-	M8
3	4	Q3H100L4D	Aluminium	191	400	1xM25	140	160	100	243	12	28	60	31,0	8	6306-ZZ	6205-ZZ	30*47*7	30*47*7	160	110	130	-	M8
3	6	Q3H132S6A	Aluminium	260	481	1xM32	140-178	216	132	312	12	38	80	41,0	10	6208-ZZ	6208-ZZ	40*62*10	40*62*10	200	130	165	-	M10
4	2	Q3H112M2C	Aluminium	191	399	1xM25	140	190	112	254	12	28	60	31,0	8	6306-ZZ	6205-ZZ	30*47*7	25*40*7	160	110	130	-	M8
4	4	Q3H112M4D	Aluminium	210	396	1xM25	140	190	112	265	12	28	60	31,0	8	6306-ZZ	6206-ZZ	30*47*7	30*47*7	160	110	130	-	M8
4	6	Q3H132M6A	Aluminium	260	481	1xM32	140-178	216	132	312	12	38	80	41,0	10	6208-ZZ	6208-ZZ	40*62*10	40*62*10	200	130	165	-	M10
5,5	2	Q3H132S2C	Aluminium	210	422	1xM25	140-178	216	132	283	12	38	80	41,0	10	6208-ZZ	6206-ZZ	40*62*10	30*47*7	200	130	165	-	M10
5,5	4	Q3H132S4B	Aluminium	260	481	1xM32	140-178	216	132	312	12	38	80	41,0	10	6208-ZZ	6208-ZZ	40*62*10	40*62*10	200	130	165	-	M10
5,5	6	Q3H132M6B	Aluminium	260	481	1xM32	140-178	216	132	312	12	38	80	41,0	10	6208-ZZ	6208-ZZ	40*62*10	40*62*10	200	130	165	-	M10
7,5	2	Q3H132S2D	Aluminium	210	448	1xM25	140-178	216	132	283	12	38	80	41,0	10	6208-ZZ	6206-ZZ	40*62*10	30*47*7	200	130	165	-	M10
7,5	4	Q3H132M4D	Aluminium	260	481	1xM32	140-178	216	132	312	12	38	80	41,0	10	6208-ZZ	6208-ZZ	40*62*10	40*62*10	200	130	165	-	M10

(1) Toleranslar 28 mm'ye kadar DIN EN 50347 "j6", 28 mm ve üzeri "k6" / Tolerance DIN EN 50347 "j6" up to 28mm, "k6" above 28mm

(2) DIN 6885'e göre / According to DIN 6885

(3) Tolerans DIN EN 50347 "j6" / Tolerance DIN EN 50347 "j6"

BOYUTLAR - B14b, B34b / DIMENSION - B14b, B34b

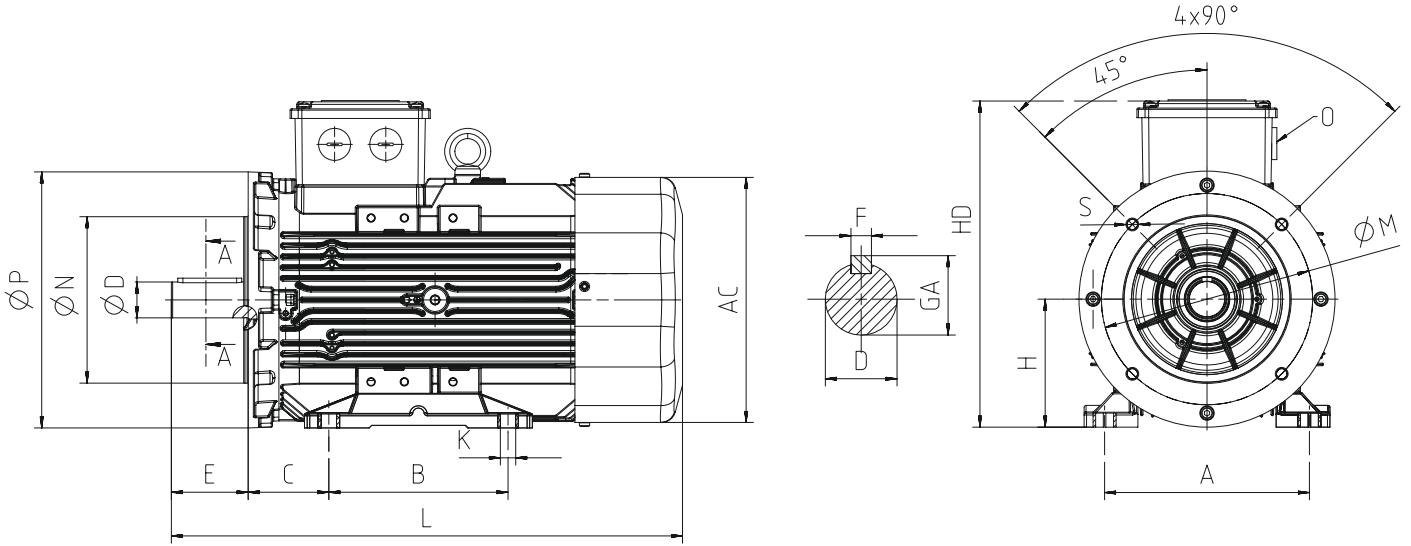

Güç Power (kW)	Kutup sayısı Number of Poles	Motor Tipi Motor Type	Gövde Tipi Housing Type	Ana Boyutlar Main Dimensions			Ayaklı Motorlar Foot Mounted Motors					Mil Shaft		Rulman Bearing		Keçe Seal		Flanş (FB) (B14b) Flange (FB) (B14b)						
				AC	L	O	B	A	H	HD	K	D ⁽¹⁾	E	GA	F ⁽²⁾	Kasnak Tarafı Drive Side	Kasnak Tarafı Aksı Non drive Side	Kasnak Tarafı Drive Side	Kasnak Tarafı Aksı Non drive Side	P	N ⁽³⁾	M	R	S
0,75	2	Q3H80M2C	Aluminium	158	268	1xM20	100	125	80	216	10	19	40	21,5	6	6204-ZZ	6204-ZZ	20*30*7	20*30*7	160	110	130	-	M8
0,75	4	Q3H80M4D	Aluminium	158	268	1xM20	100	125	80	216	10	19	40	21,5	6	6204-ZZ	6204-ZZ	20*30*7	20*30*7	160	110	130	-	M8
0,75	6	Q3H90L6C	Aluminium	172	344	1xM25	100-125	140	90	223	10	24	50	27,0	8	6305-ZZ	6205-ZZ	25*40*7	25*40*7	160	110	130	-	M8
1,1	2	Q3H80M2D	Aluminium	158	268	1xM20	100	125	80	216	10	19	40	21,5	6	6204-ZZ	6204-ZZ	20*30*7	20*30*7	160	110	130	-	M8
1,1	4	Q3H90L4C	Aluminium	158	303	1xM25	100-125	140	90	213	10	24	50	27,0	8	6305-ZZ	6204-ZZ	25*40*7	20*30*7	160	110	130	-	M8
1,1	6	Q3H90L6D	Aluminium	172	344	1xM25	100-125	140	90	223	10	24	50	27,0	8	6305-ZZ	6205-ZZ	25*40*7	25*40*7	160	110	130	-	M8
1,5	2	Q3H90L2C	Aluminium	158	303	1xM25	100-125	140	90	213	10	24	50	27,0	8	6305-ZZ	6204-ZZ	25*40*7	20*30*7	160	110	130	-	M8
1,5	4	Q3H90L4D	Aluminium	172	344	1xM25	100-125	140	90	223	10	24	50	27,0	8	6305-ZZ	6205-ZZ	25*40*7	25*40*7	160	110	130	-	M8
1,5	6	Q3H100L6D	Aluminium	191	400	1xM25	140	160	100	243	12	28	60	31,0	8	6306-ZZ	6205-ZZ	30*47*7	30*47*7	200	130	130	-	M10
2,2	2	Q3H90L2D	Aluminium	172	344	1xM25	100-125	140	90	223	10	24	50	27,0	8	6305-ZZ	6205-ZZ	25*40*7	25*40*7	260	110	130	-	M8
2,2	4	Q3H100L4C	Aluminium	172	384	1xM25	140	160	100	233	12	28	60	31,0	8	6306-ZZ	6205-ZZ	30*47*7	25*40*7	200	130	165	-	M10
2,2	6	Q3H112M6D	Aluminium	210	396	1xM25	140	190	112	265	12	28	60	31,0	8	6306-ZZ	6206-ZZ	30*47*7	30*47*7	200	130	165	-	M10
3	2	Q3H100L2D	Aluminium	172	349	1xM25	140	160	100	233	12	28	60	31,0	8	6306-ZZ	6205-ZZ	30*47*7	25*40*7	200	130	165	-	M10
3	4	Q3H100L4D	Aluminium	191	400	1xM25	140	160	100	243	12	28	60	31,0	8	6306-ZZ	6205-ZZ	30*47*7	30*47*7	200	130	165	-	M10
3	6	Q3H132S6A	Aluminium	260	481	1xM32	140-178	216	132	312	12	38	80	41,0	10	6208-ZZ	6208-ZZ	40*62*10	40*62*10	250	180	215	-	M12
4	2	Q3H112M2C	Aluminium	191	399	1xM25	140	190	112	254	12	28	60	31,0	8	6306-ZZ	6205-ZZ	30*47*7	25*40*7	200	130	165	-	M10
4	4	Q3H112M4D	Aluminium	210	396	1xM25	140	190	112	265	12	28	60	31,0	8	6306-ZZ	6206-ZZ	30*47*7	30*47*7	200	130	165	-	M10
4	6	Q3H132M6A	Aluminium	260	481	1xM32	140-178	216	132	312	12	38	80	41,0	10	6208-ZZ	6208-ZZ	40*62*10	40*62*10	250	180	215	-	M12
5,5	2	Q3H132S2C	Aluminium	210	422	1xM25	140-178	216	132	283	12	38	80	41,0	10	6208-ZZ	6206-ZZ	40*62*10	30*47*7	250	180	215	-	M12
5,5	4	Q3H132S4B	Aluminium	260	481	1xM32	140-178	216	132	312	12	38	80	41,0	10	6208-ZZ	6208-ZZ	40*62*10	40*62*10	250	180	215	-	M12
5,5	6	Q3H132M6B	Aluminium	260	481	1xM32	140-178	216	132	312	12	38	80	41,0	10	6208-ZZ	6208-ZZ	40*62*10	40*62*10	250	180	215	-	M12
7,5	2	Q3H132S2D	Aluminium	210	448	1xM25	140-178	216	132	283	12	38	80	41,0	10	6208-ZZ	6206-ZZ	40*62*10	30*47*7	250	180	215	-	M12
7,5	4	Q3H132M4D	Aluminium	260	481	1xM32	140-178	216	132	312	12	38	80	41,0	10	6208-ZZ	6208-ZZ	40*62*10	40*62*10	250	180	215	-	M12

(1) Toleranslar 28 mm'ye kadar DIN EN 50347 "j6", 28 mm ve üzeri "k6" / Tolerance DIN EN 50347 "j6" up to 28mm, "k6" above 28mm
(2) DIN 6885'e göre / According to DIN 6885
(3) Tolerans DIN EN 50347 "j6" / Tolerance DIN EN 50347 "j6"

ELEKTRİKSEL ÖZELLİKLER - 50 Hz / ELECTRICAL CHARACTERISTICS AT 50 Hz

MOTOR TİPİ MOTOR TYPE	GÖVDE TIPI HOUSING TYPE	NOMINAL RATED VALUES					KALKIŞTAKİ DEĞERLER STARTING VALUES				Devrilme Momenti Oranı Breakdown Torque Ratio Mk/ Mn	VERİM* EFFICIENCY*			Cos φ	J	Ağırlık Weight (B3)	Ses Basınç Seviyesi Sound Pressure Level dB**	
		GÜÇ POWER		DEVİR SPEED	AKIM CURRENT	MOMENT TORQUE	AKIM CURRENT		MOMENT TORQUE			η%							
		kW	HP				I_A / I_N	$I_Δ$	M_A / M_N	$M_Δ$		4/4	3/4	2/4					
2 kutup 3000 d/dak / 2 pole 3000 rpm																			
230/400V	Q3H80M2DE	Aluminium	1,5	2,0	2905	3,2	4,9	10,9	-	5	-	5,4	84,2	83,3	80,5	0,80	0,00224	15	59
	Q3H90L2E	Aluminium	3,0	4,0	2890	5,8	9,9	8,1	-	3	-	3,5	87,1	88,1	87,7	0,86	0,00318	19	63
400/690V	Q3H100L2DE	Aluminium	4,0	5,5	2936	8,0	13,0	3,6	10,9	1,6	4,8	5,7	88,1	88,1	85,8	0,82	0,00611	29	66
	Q3H112M2D	Aluminium	5,5	7,5	2920	10,5	18,1	3,5	10,5	1,2	3,7	5,1	89,2	89,0	87,2	0,86	0,00741	32	68
	Q3H112M2DE	Aluminium	7,5	10,0	2918	13,6	24,5	3,6	10,7	1,4	4,3	5,4	90,1	90,3	89,1	0,88	0,00921	42	69
	Q3H132M2A	Aluminium	11,0	15,0	2925	20,7	36,0	3,5	10,5	1,3	3,9	5,2	91,2	91,4	90,6	0,85	0,03489	61	69
	Q3H132M2B	Aluminium	15,0	20,0	2935	27,6	48,8	3,5	10,4	1,2	3,7	5,2	91,9	91,3	89,8	0,86	0,00402	77	71
	Q3H160L2D	Aluminium	22,0	30,0	2961	39,1	71,0	3,5	10,6	1,2	3,6	5,1	92,7	92,4	91,3	0,87	0,05539	114	70
	Q3H180M2B	Aluminium	30,0	40,0	2957	50,1	96,9	3,2	9,6	1,0	2,9	3,9	93,3	93,2	92,6	0,93	0,10277	148	77
Q3H200L2DE	Aluminium	45,0	60,0	2964	75,2	145,0	3,6	10,7	1,0	3,0	2,7	94,0	93,3	92,8	0,92	0,14769	199	78	
4 kutup 1500 d/dak / 4 pole 1500 rpm																			
230/400V	Q3H80M4DE	Aluminium	1,1	1,5	1448	2,6	7,3	7,2	-	3,1	-	3,7	82,7	82,4	89,5	0,75	0,00306	14	48
	Q3H90L4DE	Aluminium	2,2	3,0	1453	5,4	14,4	9,5	-	5,0	-	5,5	86,7	84,3	80,6	0,68	0,00690	25	54
400/690V	Q3H100L4E	Aluminium	4,0	5,5	1445	8,8	26,4	8,6	-	3,5	-	4,2	88,6	87,1	85,6	0,75	0,01124	35	56
	Q3H112M4E	Aluminium	5,5	7,5	1443	11,25	36,4	2,8	8,3	1,0	3,1	3,8	89,6	89,2	88,3	0,80	0,01526	40	57
	Q3H132M4E	Aluminium	11,0	15,0	1470	19,2	71,3	2,7	8,0	0,7	2,1	3,8	91,4	91,5	90,4	0,90	0,05940	82	63
	Q3H160L4C	Aluminium	18,5	25,0	1474	39,5	119,9	2,5	7,4	0,8	2,3	3,5	92,6	91,9	91,2	0,74	0,10511	114	58
	Q3H180L4C	Aluminium	30,0	40,0	1475	54,8	194,2	2,5	7,6	0,8	2,3	2,8	93,6	93,2	92,3	0,85	0,22165	187	69

* IEC 60034-2-1'e göre / According to IEC 60034-2-1

** Ses Basınç Seviyeleri motordan 1m uzaklıktan ölçülmüştür. / The sound pressure measurements are taken 1m away from the motor

*** Tolerans +3 dBA / Tolerance +3 dBA

BOYUTLAR - B3 / DIMENSION - B3

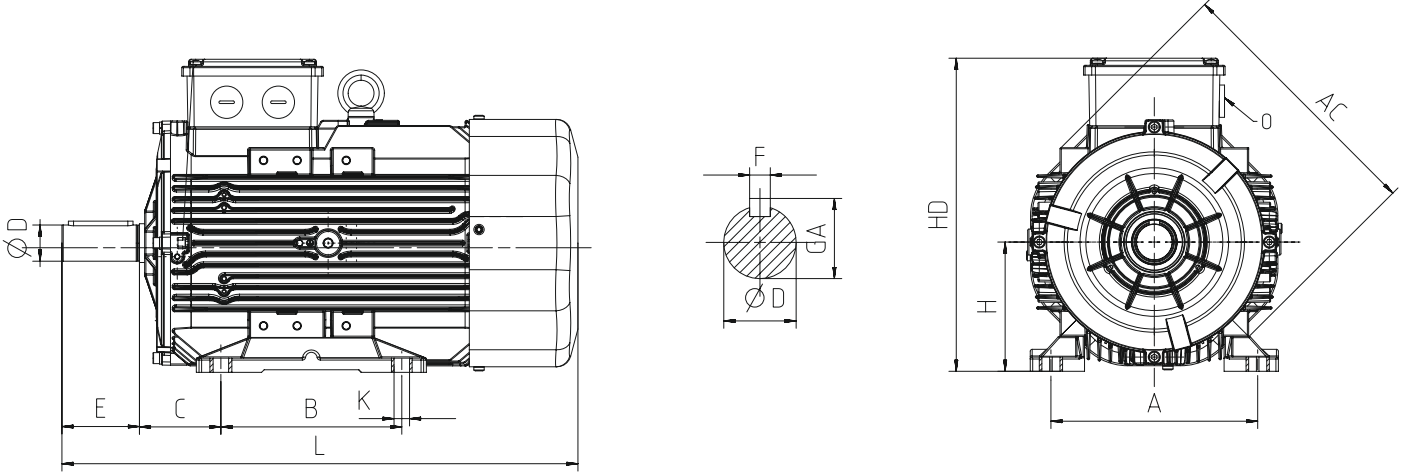

Güç Power (kW)	Kutup sayısı Number of Poles	Motor Tipi Motor Type	Gövde Tipi Housing Type	Ana Boyutlar Main Dimensions			Ayaklı Motorlar Foot Mounted Motors					Mil Shaft				Rulman Bearing		Keçe Seal		
				AC	L	O	B	A	H	HD	K	C	D ⁽¹⁾	E	GA	F ⁽²⁾	Kasnak Tarafı Drive Side	Kasnak Tarafı Aksi Non drive Side	Kasnak Tarafı Drive Side	Kasnak Tarafı Aksi Non drive Side
1,1	4	Q3H80M4DE	Aluminium	158	268	1xM20	100	125	80	216	10	50	19	40	21,5	6	6204-ZZ	6204-ZZ	20*30*7	20*30*7
1,5	2	Q3H80M2DE	Aluminium	158	268	1xM20	100	125	80	216	10	50	19	40	21,5	6	6204-ZZ	6204-ZZ	20*30*7	20*30*7
2,2	4	Q3H90L4DE	Aluminium	172	344	1xM25	100-125	140	90	223	10	56	24	50	27,0	8	6305-ZZ	6205-ZZ	25*40*7	25*40*7
3,0	2	Q3H90L2E	Aluminium	172	344	1xM25	100-125	140	90	223	10	56	24	50	27,0	8	6305-ZZ	6205-ZZ	25*40*7	25*40*7
4,0	2	Q3H100L2DE	Aluminium	191	400	1xM25	140	160	100	243	12	63	28	60	31,0	8	6306-ZZ	6205-ZZ	30*47*7	30*47*7
4,0	4	Q3H100L4E	Aluminium	191	422	1xM25	140	160	100	243	12	63	28	60	31,0	8	6306-ZZ	6205-ZZ	30*47*7	30*47*7
5,5	2	Q3H112M2D	Aluminium	210	396	1xM25	140	190	112	265	12	70	28	60	31,0	8	6306-ZZ	6206-ZZ	30*47*7	30*47*7
5,5	4	Q3H112M4E	Aluminium	210	421	1xM25	140	190	112	265	12	70	28	60	31,0	8	6306-ZZ	6206-ZZ	30*47*7	30*47*7
7,5	2	Q3H112M2DE	Aluminium	210	421	1xM25	140	190	112	265	12	70	28	60	31,0	8	6306-ZZ	6206-ZZ	30*47*7	30*47*7
11,0	2	Q3H132M2A	Aluminium	260	481	1xM32	140-178	216	132	312	12	89	38	80	41,0	10	6208-ZZ	6208-ZZ	40*62*10	40*62*10
11,0	4	Q3H132M4E	Aluminium	260	520	1xM32	140-178	216	132	312	12	89	38	80	41,0	10	6309-ZZ	6209-ZZ	40*62*10	40*62*10
15,0	2	Q3H132M2B	Aluminium	260	520	1xM32	140-178	216	132	312	12	89	38	80	41,0	10	6208-ZZ	6208-ZZ	40*62*10	40*62*10
18,5	4	Q3H160L4C	Aluminium	305	591	1xM32	210-254	254	160	368	14,5	108	42	110	45,0	12	6309-ZZ	6209-ZZ	45*72*10	45*72*10
30,0	4	Q3H180L4C	Aluminium	349	696	1xM40	241-279	279	180	437	14,5	121	48	110	51,5	14	6310-ZZ	6310-ZZ	50*80*10	50*80*10
22,0	2	Q3H160L2D	Aluminium	305	591	1xM32	210-254	254	160	368	14,5	108	42	110	45,0	12	6309-ZZ	6209-ZZ	45*72*10	45*72*10
30,0	2	Q3H180M2B	Aluminium	349	696	1xM40	241-279	279	180	437	14,5	121	48	110	51,5	14	6310-ZZ	6310-ZZ	50*80*10	50*80*10
45,0	2	Q3H200L2DE	Aluminium	349	759	1xM50	267-305	318	200	455	18,5	133	55	110	59,0	16	6312-ZZ	6310-ZZ	60*90*10	60*90*10

(1) Toleranslar 28 mm'ye kadar DIN EN 50347 "j6", 28 mm ve üzeri "k6" / Tolerance DIN EN 50347 "j6" up to 28mm, "k6" above 28mm
(2) DIN 6885'e göre / According to DIN 6885

BOYUTLAR - B5, B35 / DIMENSION - B5, B35

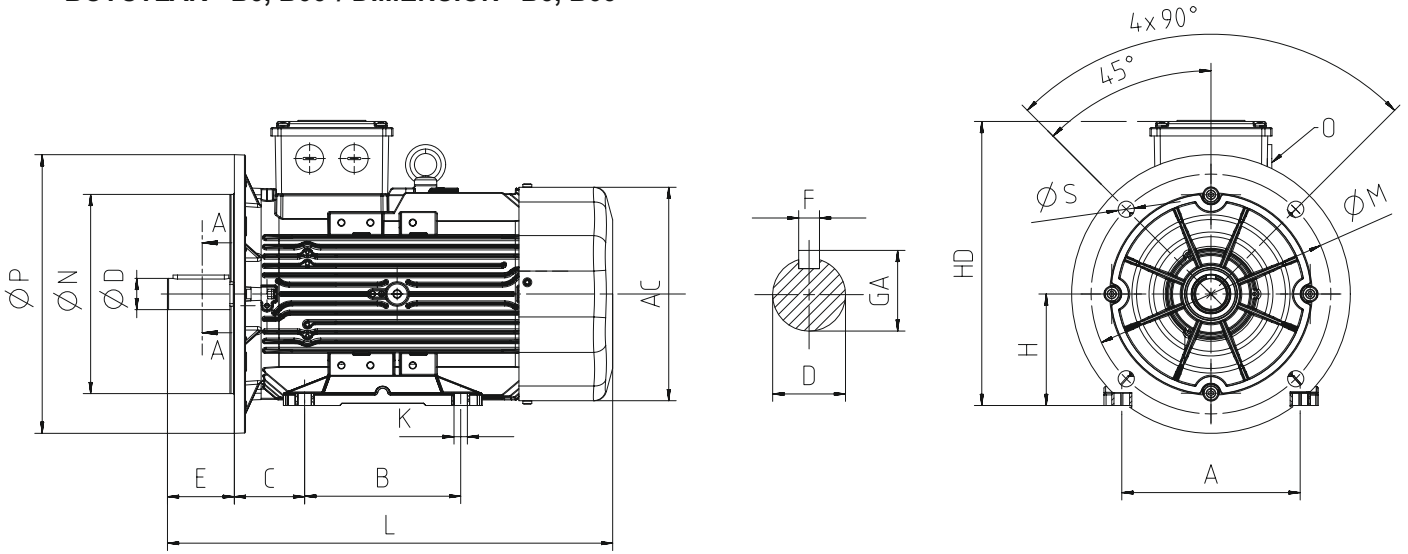

Güç Power (kW)	Kutup sayısı Number of Poles	Motor Tipi Motor Type	Gövde Tipi Housing Type	Ana Boyutlar Main Dimensions			Ayaklı Motorlar Foot Mounted Motors					Mil Shaft				Rulman Bearing		Keçe Seal		Flanş (FA) (B5) Flange (FA) (B5)				
				AC	L	O	B	A	H	HD	K	D ⁽¹⁾	E	GA	F ⁽²⁾	Kasnak Tarafı Drive Side	Kasnak Tarafı Aksı Non drive Side	Kasnak Tarafı Drive Side	Kasnak Tarafı Aksı Non drive Side	P	N ⁽³⁾	M	R	S
1,1	4	Q3H80M4DE	Aluminium	158	268	1xM20	100	125	80	216	10	19	40	21,5	6	6204-ZZ	6204-ZZ	20*30*7	20*30*7	200	130	165	-	12
1,5	2	Q3H80M2DE	Aluminium	158	268	1xM20	100	125	80	216	10	19	40	21,5	6	6204-ZZ	6204-ZZ	20*30*7	20*30*7	200	130	165	-	12
2,2	4	Q3H90L4DE	Aluminium	172	344	1xM25	100-125	140	90	223	10	24	50	27,0	8	6305-ZZ	6205-ZZ	25*40*7	25*40*7	200	130	165	-	12
3	2	Q3H90L2E	Aluminium	172	344	1xM25	100-125	140	90	223	10	24	50	27,0	8	6305-ZZ	6205-ZZ	25*40*7	25*40*7	200	130	165	-	12
4	2	Q3H100L2DE	Aluminium	191	400	1xM25	140	160	100	243	12	28	60	31,0	8	6306-ZZ	6205-ZZ	30*47*7	30*47*7	250	180	215	-	14,5
4	4	Q3H100L4E	Aluminium	191	422	1xM25	140	160	100	243	12	28	60	31,0	8	6306-ZZ	6205-ZZ	30*47*7	30*47*7	250	180	215	-	14,5
5,5	2	Q3H112M2D	Aluminium	210	396	1xM25	140	190	112	265	12	28	60	31,0	8	6306-ZZ	6206-ZZ	30*47*7	30*47*7	250	180	215	-	14,5
5,5	4	Q3H112M4E	Aluminium	210	421	1xM25	140	190	112	265	12	28	60	31,0	8	6306-ZZ	6206-ZZ	30*47*7	30*47*7	250	180	215	-	14,5
7,5	2	Q3H112M2DE	Aluminium	210	421	1xM25	140	190	112	265	12	28	60	31,0	8	6306-ZZ	6206-ZZ	30*47*7	30*47*7	250	180	215	-	14,5
11	2	Q3H132M2A	Aluminium	260	481	1xM32	140-178	216	132	312	12	38	80	41,0	10	6208-ZZ	6208-ZZ	40*62*10	40*62*10	300	230	265	-	14,5
11	4	Q3H132M4E	Aluminium	260	520	1xM32	140-178	216	132	312	12	38	80	41,0	10	6309-ZZ	6209-ZZ	40*62*10	40*62*10	300	230	265	-	14,5
15	2	Q3H132M2B	Aluminium	260	520	1xM32	140-178	216	132	312	12	38	80	41,0	10	6208-ZZ	6208-ZZ	40*62*10	40*62*10	300	230	265	-	14,5
18,5	4	Q3H160L4C	Aluminium	305	591	1xM32	210-254	254	160	368	14,5	42	110	45,0	12	6309-ZZ	6209-ZZ	45*72*10	45*72*10	350	250	300	-	18,5
30	4	Q3H180L4C	Aluminium	349	696	1xM40	241-279	279	180	437	14,5	48	110	51,5	14	6310-ZZ	6310-ZZ	50*80*10	50*80*10	350	250	300	-	18,5
22	2	Q3H160L2D	Aluminium	305	591	1xM32	210-254	254	160	368	14,5	42	110	45,0	12	6309-ZZ	6209-ZZ	45*72*10	45*72*10	350	250	300	-	18,5
30	2	Q3H180M2B	Aluminium	349	696	1xM40	241-279	279	180	437	14,5	48	110	51,5	14	6310-ZZ	6310-ZZ	50*80*10	50*80*10	350	250	300	-	18,5
45	2	Q3H200L2DE	Aluminium	349	759	1xM50	267-305	318	200	455	18,5	55	110	59,0	16	6312-ZZ	6310-ZZ	60*90*10	60*90*10	400	300	350	-	18,5

(1) Toleranslar 28 mm'ye kadar DIN EN 50347 "j6", 28 mm ve üzeri "k6" / Tolerance DIN EN 50347 "j6" up to 28mm, "k6" above 28mm

(2) DIN 6885'e göre / According to DIN 6885

(3) Tolerans DIN EN 50347 "j6" / Tolerance DIN EN 50347 "j6"

BOYUTLAR - B14a, B34a / DIMENSION - B14a, B34a

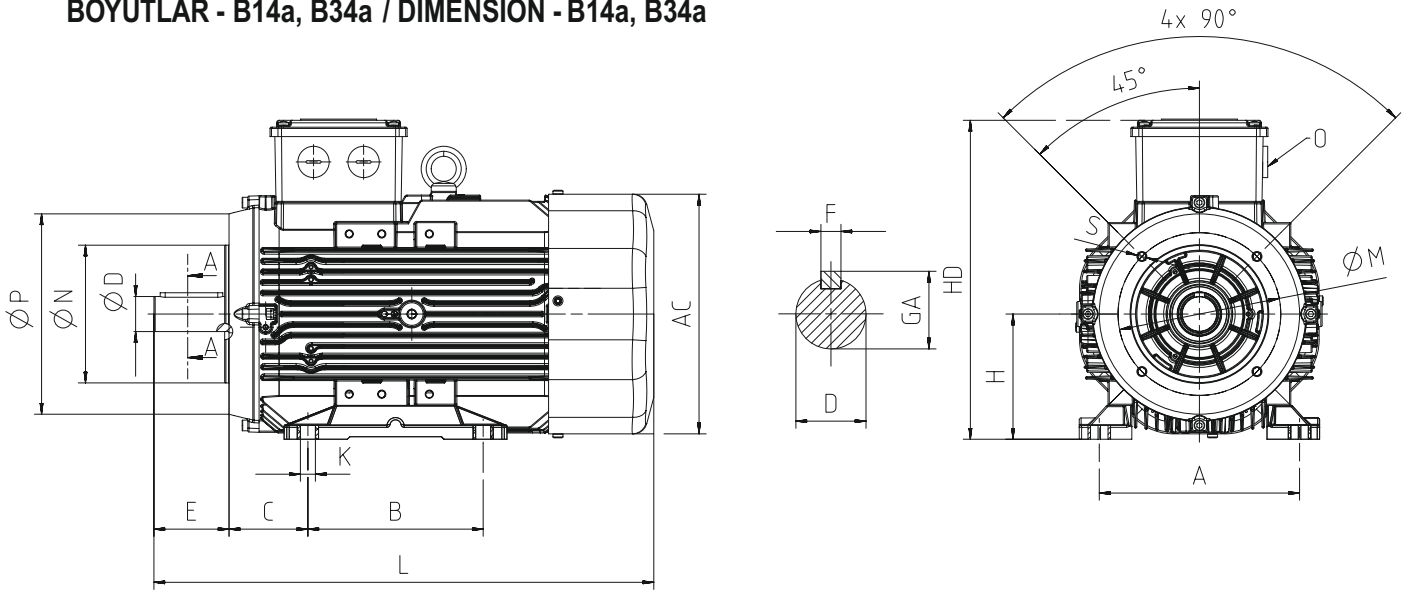

Güç Power (kW)	Kutup sayısı Number of Poles	Motor Tipi Motor Type	Gövde Tipi Housing Type	Ana Boyutlar Main Dimensions			Ayaklı Motorlar Foot Mounted Motors					Mil Shaft			Rulman Bearing		Keçe Seal		Flanş (FC) (B14a) Flange (FC) (B14a)					
				AC	L	O	B	A	H	HD	K	D ⁽¹⁾	E	GA	F ⁽²⁾	Kasnak Tarafı Drive Side	Kasnak Tarafı Aksi Non drive Side	Kasnak Tarafı Drive Side	Kasnak Tarafı Aksi Non drive Side	P	N ⁽³⁾	M	R	S
1,1	4	Q3H80M4DE	Aluminium	158	268	1xM20	100	125	80	216	10	19	40	21,5	6	6204-ZZ	6204-ZZ	20*30*7	20*30*7	120	80	100	-	M6
1,5	2	Q3H80M2DE	Aluminium	158	268	1xM20	100	125	80	216	10	19	40	21,5	6	6204-ZZ	6204-ZZ	20*30*7	20*30*7	120	80	100	-	M6
2,2	4	Q3H90L4DE	Aluminium	172	344	1xM25	100-125	140	90	223	10	24	50	27,0	8	6305-ZZ	6205-ZZ	25*40*7	25*40*7	140	95	115	-	M8
3	2	Q3H90L2E	Aluminium	172	344	1xM25	100-125	140	90	223	10	24	50	27,0	8	6305-ZZ	6205-ZZ	25*40*7	25*40*7	140	95	115	-	M8
4	2	Q3H100L2DE	Aluminium	191	400	1xM25	140	160	100	243	12	28	60	31,0	8	6306-ZZ	6205-ZZ	30*47*7	30*47*7	160	110	130	-	M8
4	4	Q3H100L4E	Aluminium	191	422	1xM25	140	160	100	243	12	28	60	31,0	8	6306-ZZ	6205-ZZ	30*47*7	30*47*7	160	110	130	-	M8
5,5	2	Q3H112M2D	Aluminium	210	396	1xM25	140	190	112	265	12	28	60	31,0	8	6306-ZZ	6206-ZZ	30*47*7	30*47*7	160	110	130	-	M8
5,5	4	Q3H112M4E	Aluminium	210	421	1xM25	140	190	112	265	12	28	60	31,0	8	6306-ZZ	6206-ZZ	30*47*7	30*47*7	160	110	130	-	M8
7,5	2	Q3H112M2DE	Aluminium	210	421	1xM25	140	190	112	265	12	28	60	31,0	8	6306-ZZ	6206-ZZ	30*47*7	30*47*7	160	110	130	-	M8
11	2	Q3H132M2A	Aluminium	260	481	1xM32	140-178	216	132	312	12	38	80	41,0	10	6208-ZZ	6208-ZZ	40*62*10	40*62*10	200	130	165	-	M10
11	4	Q3H132M4E	Aluminium	260	520	1xM32	140-178	216	132	312	12	38	80	41,0	10	6208-ZZ	6208-ZZ	40*62*10	40*62*10	200	130	165	-	M10
15	2	Q3H132M2B	Aluminium	260	520	1xM32	140-178	216	132	312	12	38	80	41,0	10	6208-ZZ	6208-ZZ	40*62*10	40*62*10	200	130	165	-	M10

(1) Toleranslar 28 mm'ye kadar DIN EN 50347 "j6", 28 mm ve üzeri "k6" / Tolerance DIN EN 50347 "j6" up to 28mm, "k6" above 28mm

(2) DIN 6885'e göre / According to DIN 6885

(3) Tolerans DIN EN 50347 "j6" / Tolerance DIN EN 50347 "j6"

BOYUTLAR - B14b, B34b / DIMENSION - B14b, B34b

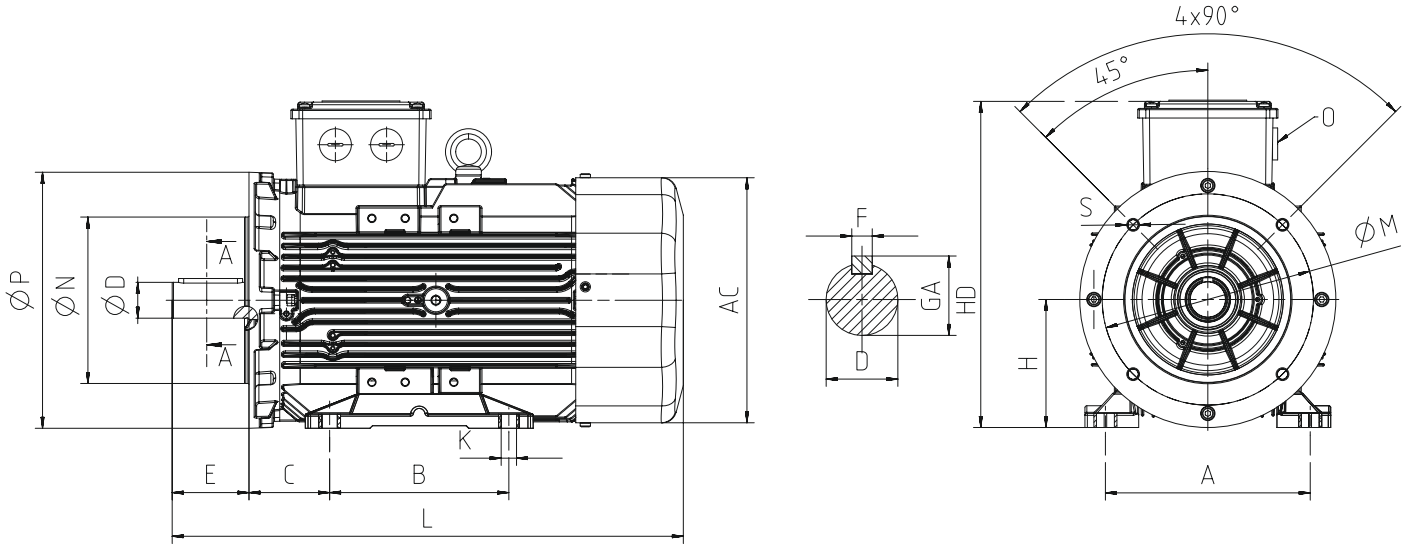

Güç Power (kW)	Kutup sayısı Number of Poles	Motor Tipi Motor Type	Gövde Tipi Housing Type	Ana Boyutlar Main Dimensions			Ayaklı Motorlar Foot Mounted Motors					Mil Shaft				Rulman Bearing		Keçe Seal		Flanş (FB) (B14b) Flange (FB) (B14b)				
				AC	L	O	B	A	H	HD	K	D ⁽¹⁾	E	GA	F ⁽²⁾	Kasnak Tarafı Drive Side	Kasnak Tarafı Aksı Non drive Side	Kasnak Tarafı Drive Side	Kasnak Tarafı Aksı Non drive Side	P	N ⁽³⁾	M	R	S
1,1	4	Q3H80M4DE	Aluminium	158	268	1xM20	100	125	80	216	10	19	40	21,5	6	6204-ZZ	6204-ZZ	20*30*7	20*30*7	160	110	130	-	M8
1,5	2	Q3H80M2DE	Aluminium	158	268	1xM20	100	125	80	216	10	19	40	21,5	6	6204-ZZ	6204-ZZ	20*30*7	20*30*7	160	110	130	-	M8
2,2	4	Q3H90L4DE	Aluminium	172	344	1xM25	100-125	140	90	223	10	24	50	27,0	8	6305-ZZ	6205-ZZ	25*40*7	25*40*7	160	110	130	-	M8
3	2	Q3H90L2E	Aluminium	172	344	1xM25	100-125	140	90	223	10	24	50	27,0	8	6305-ZZ	6205-ZZ	25*40*7	25*40*7	160	110	130	-	M8
4	2	Q3H100L2DE	Aluminium	191	400	1xM25	140	160	100	243	12	28	60	31,0	8	6306-ZZ	6205-ZZ	30*47*7	30*47*7	200	130	165	-	M10
4	4	Q3H100L4E	Aluminium	191	422	1xM25	140	160	100	243	12	28	60	31,0	8	6306-ZZ	6205-ZZ	30*47*7	30*47*7	200	130	165	-	M10
5,5	2	Q3H112M2D	Aluminium	210	396	1xM25	140	190	112	265	12	28	60	31,0	8	6306-ZZ	6206-ZZ	30*47*7	30*47*7	200	130	165	-	M10
5,5	4	Q3H112M4E	Aluminium	210	421	1xM25	140	190	112	265	12	28	60	31,0	8	6306-ZZ	6206-ZZ	30*47*7	30*47*7	200	130	165	-	M10
7,5	2	Q3H112M2DE	Aluminium	210	421	1xM25	140	190	112	265	12	28	60	31,0	8	6306-ZZ	6206-ZZ	30*47*7	30*47*7	200	130	165	-	M10
11	2	Q3H132M2A	Aluminium	260	481	1xM32	140-178	216	132	312	12	38	80	41,0	10	6208-ZZ	6208-ZZ	40*62*10	40*62*10	250	180	215	-	M12
11	4	Q3H132M4E	Aluminium	260	520	1xM32	140-178	216	132	312	12	38	80	41,0	10	6208-ZZ	6208-ZZ	40*62*10	40*62*10	250	180	215	-	M12
15	2	Q3H132M2B	Aluminium	260	520	1xM32	140-178	216	132	312	12	38	80	41,0	10	6208-ZZ	6208-ZZ	40*62*10	40*62*10	250	180	215	-	M12

(1) Toleranslar 28 mm'ye kadar DIN EN 50347 "j6", 28 mm ve üzeri "k6" / Tolerance DIN EN 50347 "j6" up to 28mm, "k6" above 28mm

(2) DIN 6885'e göre / According to DIN 6885

(3) Tolerans DIN EN 50347 "j6" / Tolerance DIN EN 50347 "j6"

IE2

ELEKTRİKSEL ÖZELLİKLER - 50 Hz / ELECTRICAL CHARACTERISTICS AT 50 Hz

MOTOR TİPİ MOTOR TYPE	GÖVDE TIPI HOUSING TYPE	NOMINAL RATED VALUES						KALKIŞTAKİ DEĞERLER STARTING VALUES				Devrilme Momenti Oranı Breakdown Torque Ratio Mk/ Mn	VERİM* EFFICIENCY*			Cos φ	J	Ağırlık Weight (B3)	Ses Basınç Seviyesi Sound Pressure Level dBA**
		GÜÇ POWER		DEVİR SPEED	AKIM CURRENT	MOMENT TORQUE	AKIM CURRENT		MOMENT TORQUE		η%								
		kW	HP				rpm	A	Nm	I_A / I_N	$I_Δ / I_N$		M_A / M_N	$M_Δ / M_N$	4/4				
2 kutup 3000 d/dak / 2 pole 3000 rpm																			
230/400V	Q2E63M2A	Aluminium	0,18	1/4	2810	0,4	0,6	4,7	-	2,1	-	2,3	59,1	63,8	58,5	0,85	0,00022	5	52
	Q2E63M2B	Aluminium	0,25	1/3	2820	0,6	0,8	5,6	-	2,7	-	2,7	64,7	66,2	63,5	0,84	0,00025	6	52
	Q2E71M2A	Aluminium	0,37	1/2	2850	0,8	1,2	8,1	-	4,0	-	4,2	69,5	69,6	67,3	0,80	0,00067	8	54
	Q2E71M2B	Aluminium	0,55	3/4	2880	1,2	1,8	8,2	-	4,1	-	4,3	74,1	74,3	74,2	0,82	0,00086	10	54
	Q2H80M2B	Aluminium	0,75	1,0	2850	1,7	2,5	6,4	-	2,8	-	3,3	77,4	77,6	74,4	0,82	0,00111	9	58
	Q2H80M2C	Aluminium	1,1	1,5	2860	2,5	3,7	6,7	-	2,8	-	3,3	79,6	79,8	77,0	0,81	0,00140	11	58
	Q2H90L2B	Aluminium	1,5	2,0	2875	3,8	5,0	8,0	-	3,9	-	4,4	81,3	80,4	76,6	0,74	0,00176	13	62
	Q2H90L2D	Aluminium	2,2	3,0	2870	4,7	7,3	9,1	-	3,9	-	4,4	83,2	82,8	81,3	0,83	0,00231	16	62
	Q2H100L2C	Aluminium	3,0	4,0	2887	6,3	9,9	7,3	-	2,4	-	2,9	84,6	85,4	84,2	0,83	0,00266	19	66
400/690V	Q2H112M2B	Aluminium	4,0	5,5	2900	8,0	13,2	3,1	9,3	1,1	3,2	4,0	85,8	86,1	84,5	0,85	0,00487	24	68
	Q2H132S2B	Aluminium	5,5	7,5	2915	10,6	18,0	3,5	10,6	1,5	4,4	5,3	87,0	87,1	84,9	0,86	0,00703	34	69
	Q2H132S2C	Aluminium	7,5	10,0	2900	14,6	24,7	3,5	10,6	1,3	3,8	4,6	88,1	88,6	87,6	0,85	0,00772	37	69
	Q2H160M2B	Aluminium	11,0	15,0	2923	21,2	35,9	3,1	9,2	1,1	3,3	4,8	89,4	89,9	88,4	0,83	0,03517	65	70
	Q2H160M2C	Aluminium	15,0	20,0	2915	30,0	49,2	3,2	9,6	1,3	3,9	5,1	90,3	90,6	89,6	0,80	0,04015	67	70
	Q2H160M2D	Aluminium	18,5	25,0	2930	30,8	60,3	2,7	8,0	0,6	1,9	3,6	90,9	91,7	91,1	0,95	0,04613	79	70
	Q2H180M2A	Aluminium	22,0	30,0	2955	40,9	71,2	3,5	10,6	1,2	3,6	5,2	91,3	92,0	90,7	0,84	0,05141	100	77
	Q2H200L2B	Aluminium	30,0	40,0	2955	51,5	97,1	2,8	8,5	0,8	2,4	3,6	92,0	92,5	91,8	0,91	0,08644	175	78
	Q2H200L2C	Aluminium	37,0	50,0	2965	66,2	119,6	3,4	10,1	1,0	3,1	4,5	92,5	92,5	91,2	0,87	0,10277	175	78
	Q2E225M2B	Aluminium	45,0	60,0	2960	82,1	145,2	2,9	8,7	0,8	2,4	2,9	92,9	92,6	91,1	0,85	0,23500	235	81
	Q2E250M2A	Cast Iron	55,0	75,0	2976	92,7	177,0	2,8	8,4	0,8	2,5	3,4	93,2	93,0	91,6	0,91	0,48700	486	82
	Q2EP280M2B	Cast Iron	75,0	100,0	2975	127,9	240,8	3,5	10,6	0,9	2,7	5,1	93,8	93,7	92,5	0,92	0,54000	576	84
	Q2EP280M2C	Cast Iron	90,0	125,0	2980	149,0	288,6	2,4	7,1	1,0	3,0	3,0	94,1	93,9	92,9	0,91	0,64500	585	84
	Q2EP315S2C	Cast Iron	110,0	127	2,975	185	353	2,6	7,8	0,7	2,2	2,4	94,3	94,3	93,1	0,91	1,43600	920	87
	Q2EP315M2C	Cast Iron	132,0	152	2,975	221	423	2,6	7,8	0,8	2,3	2,4	94,6	94,6	93,4	0,91	1,72300	970	87
	Q2EP315L2C	Cast Iron	160,0	184	2,975	268	513	2,5	7,5	0,8	2,3	2,4	94,8	94,8	93,6	0,91	1,95300	1170	87
	Q2EP315L2D	Cast Iron	200,0	230	2,975	334	643	2,7	8	0,8	2,4	2,6	95	95	93,8	0,91	2,52700	1200	87
	Q2EP355M2C	Cast Iron	250,0	280	2,985	422	799	2,3	7	0,7	2	2,4	95	95	93,8	0,90	3,92000	1690	87
Q2EP355L2C	Cast Iron	315,0	353,0	2,985	532	1.007	2,5	7,4	0,7	2,0	2,3	95,0	95,0	93,8	0,90	4,17000	1.870	87	
Q2EP355L2D	Cast Iron	355,0	398,0	2985	599	1.135	2,5	7,5	0,6	1,8	2,1	95,0	95,0	93,8	0,90	4,44000	1953	87	

* IEC 60034-2-1'e göre / According to IEC 60034-2-1

** Ses Basınç Seviyeleri motordan 1m uzaklıktan ölçülmüştür. / The sound pressure measurements are taken 1m away from the motor

*** Tolerans +3 dBA / Tolerance +3 dBA

MOTOR TİPİ MOTOR TYPE	GÖVDE TIPI HOUSING TYPE	NOMİNAL RATED VALUES					KALKIŞTAKİ DEĞERLER STARTING VALUES				Devrilme Momenti Oranı Breakdown Torque Ratio Mk/ Mn	VERİM* EFFICIENCY*			Cos φ	J kgm ²	Ağırlık Weight (B3) kg	Ses Basınç Seviyesi Sound Pressure Level dBA **	
		GÜÇ POWER		DEVİR SPEED rpm	AKIM CURRENT A	MOMENT TORQUE Nm	AKIM CURRENT I _A / I _N		MOMENT TORQUE M _A / M _N			η%							
		kW	HP				λ	Δ	λ	Δ		4/4	3/4	2/4					
4 kutup 1500 d/dak / 4 pole 1500 rpm																			
230/400V	Q2E63M4A	Aluminium	0,12	1/6	1420	0,5	0,9	3,4	-	2,2	-	3,2	64,0	54,1	44,9	0,56	0,00022	5	41
	Q2E63M4B	Aluminium	0,18	1/4	1400	0,6	1,2	3,7	-	2,7	-	3,0	68,0	60,0	51,3	0,66	0,00026	6	41
	Q2E71M4A	Aluminium	0,25	1/3	1415	0,6	1,7	4,6	-	2,6	-	3,8	68,5	68,8	66,9	0,70	0,00095	9	45
	Q2E71M4B	Aluminium	0,37	1/2	1425	1,1	2,5	4,6	-	2,6	-	3,8	72,7	73,1	72,0	0,71	0,00095	9	45
	Q2H80M4B	Aluminium	0,55	3/4	1435	1,3	3,6	6,4	-	2,3	-	3,2	77,1	78,8	75,4	0,76	0,00175	10	49
	Q2H80M4C	Aluminium	0,75	1,0	1440	1,8	5,0	5,5	-	2,1	-	2,6	79,6	80,0	77,7	0,76	0,00216	11	49
	Q2H90L4C	Aluminium	1,10	1,5	1430	2,5	7,4	5,7	-	2,2	-	2,6	81,4	82,4	81,6	0,80	0,00267	13	54
	Q2H90L4C	Aluminium	1,50	2,0	1427	3,3	10,0	6,4	-	2,5	-	3,1	82,8	84,2	83,7	0,79	0,00328	15	54
	Q2H100L4B	Aluminium	2,20	3,0	1437	5,3	14,6	7,6	-	3,6	-	4,2	84,3	84,1	81,5	0,72	0,00521	21	55
Q2H100L4C	Aluminium	3,00	4,0	1440	7,4	20,0	6,5	-	3,3	-	3,7	85,5	85,3	83,0	0,70	0,00694	25	55	
400/690V	Q2H112M4C	Aluminium	4,00	5,5	1440	8,7	26,6	2,7	8,0	1,1	3,2	3,8	86,6	85,7	83,5	0,78	0,01085	31	58
	Q2H132S4A	Aluminium	5,50	7,5	1445	11,5	35,5	2,7	8,0	1,0	3,0	3,8	87,7	88,3	87,3	0,79	0,01414	38	59
	Q2H132M4C	Aluminium	7,50	10,0	1460	15,0	49,1	2,4	7,1	0,5	1,5	0,6	88,7	89,4	88,7	0,82	0,03560	54	62
	Q2H160M4C	Aluminium	11,00	15,0	1468	21,6	71,5	2,6	7,9	0,7	2,1	3,6	89,8	91,1	90,3	0,81	0,05468	79	63
	Q2H160L4B	Aluminium	15,00	20,0	1462	29,8	98,0	2,6	7,8	0,6	1,8	3,4	90,6	91,4	90,9	0,80	0,05940	83	63
	Q2H180M4A	Aluminium	18,50	25,0	1470	36,0	120,2	2,3	6,8	0,7	2,2	2,9	91,2	92,0	91,6	0,81	0,10513	110	67
	Q2H180M4B	Aluminium	22,00	30,0	1462	41,8	143,8	1,8	5,5	0,6	1,9	2,8	91,6	92,9	93,3	0,84	0,11398	118	67
	Q2H200L4C	Aluminium	30,00	40,0	1475	55,3	194,6	2,7	8,2	0,9	2,7	3,5	92,0	91,9	91,4	0,85	0,18660	195	70
	Q2E225M4A	Aluminium	37,00	50,0	1480	68,3	238,8	3,0	9,1	1,2	3,6	4,0	92,7	92,6	91,3	0,84	0,36420	263	71
	Q2E225M4B	Aluminium	45,00	60,0	1480	81,5	290,5	3,1	9,4	1,2	3,7	3,0	93,1	93,0	91,9	0,85	0,43500	280	71
	Q2E250M4A	Cast Iron	55,00	75,0	1486	104,8	353,5	2,4	7,2	0,8	2,3	3,0	93,5	93,7	93,3	0,81	0,36400	506	72
	Q2EP280M4B	Cast Iron	75,00	100,0	1485	134,2	485,7	2,6	7,8	1,0	2,9	3,4	94,0	93,9	93,2	0,86	1,06100	624	73
	Q2EP280M4C	Cast Iron	90,00	125,0	1486	163,5	584,2	2,6	7,8	1,0	2,9	3,3	94,2	94,6	94,2	0,85	1,14800	638	73
	Q2EP315S4C	Cast Iron	110,0	127,0	1480	191	709	2,4	7,2	0,7	2,2	2,5	94,5	94,5	93,9	0,88	3,03500	925	70
	Q2EP315M4C	Cast Iron	132,0	152,0	1480	229	851	2,3	7,0	0,7	2,1	2,4	94,7	94,7	94,1	0,88	3,41500	1.010	70
Q2EP315L4C	Cast Iron	160,0	184,0	1480	273	1.032	2,5	7,5	0,7	2,2	2,5	94,9	94,9	94,3	0,89	4,11900	1.080	76	
Q2EP315L4D	Cast Iron	200,0	230,0	1480	341	1.290	2,5	7,5	0,8	2,3	2,5	95,1	95,1	94,5	0,89	5,20300	1.200	76	
Q2EP355M4C	Cast Iron	250,0	280,0	1485	426	1.607	2,6	7,9	0,8	2,3	2,5	95,1	95,1	94,5	0,89	8,79000	1.720	76	
Q2EP355L4C	Cast Iron	315,0	353,0	1485	531	2.025	2,5	7,4	0,7	2,0	2,3	95,1	95,1	94,5	0,90	10,13300	1.920	87	
Q2EP355L4D	Cast Iron	355,0	398,0	1485	603	2.283	2,9	8,8	0,6	1,8	2,0	95,1	95,1	94,5	0,89	10,67800	1.953	87	
6 kutup 1000 d/dak / 6 pole 1000 rpm																			
230/400V	Q2H90S6B	Aluminium	0,75	1,0	943	1,8	7,7	4,6	-	2,1	-	2,7	75,9	75,1	71,4	0,69	0,00383	16	53
	Q2H90L6C	Aluminium	1,10	1,5	938	3,0	11,2	2,8	-	2,4	-	2,8	78,1	78,0	75,1	0,69	0,00464	18	53
	Q2H100L6C	Aluminium	1,50	2,0	955	4,0	15,2	3,3	-	2,6	-	3,2	79,8	79,3	76,3	0,67	0,00871	26	56
	Q2H112M6C	Aluminium	2,20	3,0	942	5,4	22,4	5,2	-	2,0	-	2,6	81,8	81,5	79,5	0,72	0,00936	31	58
400/690V	Q2H132S6A	Aluminium	3,00	4,0	965	14,1	29,8	1,8	5,4	1,1	3,2	3,3	83,3	82,3	79,4	0,64	0,02950	47	62
	Q2H132M6A	Aluminium	4,00	5,5	970	10,4	39,8	1,9	5,8	0,7	2,2	2,6	84,6	83,5	80,7	0,65	0,03560	53	61
	Q2H132M6B	Aluminium	5,50	7,5	960	12,8	54,7	1,7	5,2	0,9	2,6	2,9	86,1	85,7	83,9	0,72	0,06420	67	60
	Q2H160M6B	Aluminium	7,50	10,0	970	18,9	74,6	2,1	6,2	1,2	3,6	3,8	87,2	84,3	81,7	0,66	0,07540	88	63
	Q2H160L6B	Aluminium	11,00	15,0	970	25,5	109,4	1,7	5,2	1,0	3,0	3,1	88,7	88,5	86,3	0,71	0,07040	99	63
	Q2H180L6A	Aluminium	15,00	20,0	970	31,5	146,9	1,8	5,1	0,6	1,8	2,0	89,7	89,5	87,30,0	0,76	0,16677	115	69
	Q2H200L6B	Aluminium	18,50	25,0	981	41,6	179,8	2,0	5,9	0,7	2,1	2,6	90,4	90,5	89,6	0,70	0,18660	160	70
	Q2H200L6C	Aluminium	22,00	30,0	982	48,8	214,5	1,8	5,6	0,8	2,3	2,4	90,9	91,0	90,3	0,72	0,20643	171	70
Q2E225M6B	Aluminium	30,00	40,0	975	57,0	287,6	1,9	5,7	0,6	1,7	2,5	91,7	91,6	90,7	0,83	0,49334	234	66	

BOYUTLAR - B3 / DIMENSION - B3

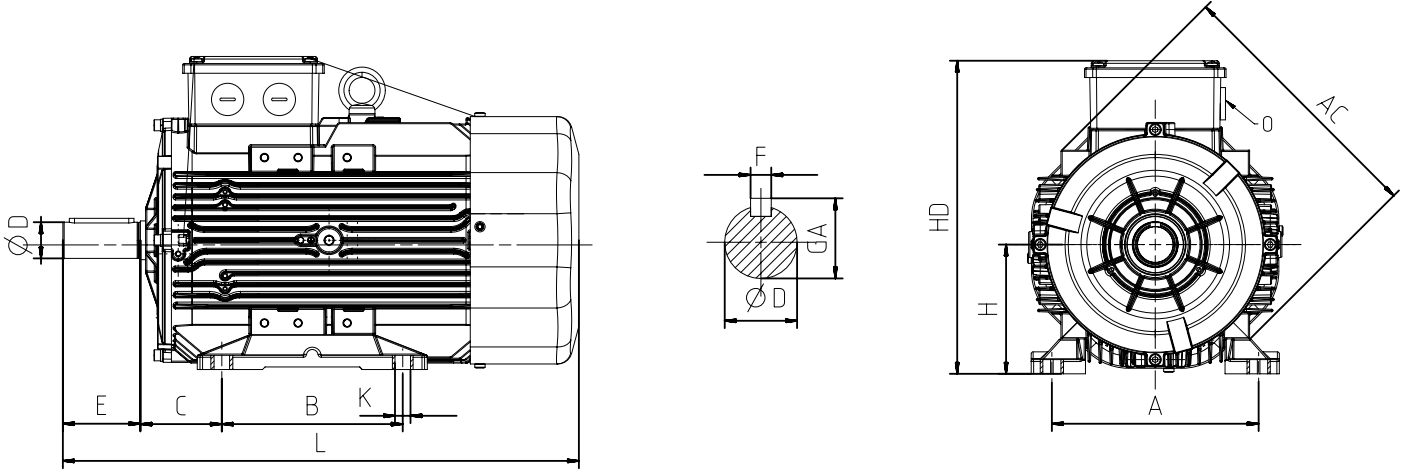

Güç Power (kW)	Kutup sayısı Number of Poles	Motor Tipi Motor Type	Gövde Tipi Housing Type	Ana Boyutlar Main Dimensions			Ayaklı Motorlar Foot Mounted Motors					Mil Shaft				Rulman Bearing		Keçe Seal		
				AC	L	O	B	A	H	HD	K	C	D ⁽¹⁾	E	GA	F ⁽²⁾	Kasnak Taraflı Drive Side	Kasnak Taraflı Aksı Non Drive Side	Kasnak Taraflı Drive Side	Kasnak Taraflı Aksı Non Drive Side
0,12	4	Q2E63M4A	Aluminium	123	220	1xM20	80	100	63	162	7	40	11	23	12,5	4	6201-ZZ	6201-ZZ	12*22*7	12*22*7
0,18	2	Q2E63M2A	Aluminium	123	220	1xM20	80	100	63	162	7	40	11	23	12,5	4	6201-ZZ	6201-ZZ	12*22*7	12*22*7
0,18	4	Q2E63M4B	Aluminium	123	220	1xM20	80	100	63	162	7	40	11	23	12,5	4	6201-ZZ	6201-ZZ	12*22*7	12*22*7
0,25	2	Q2E63M2B	Aluminium	123	220	1xM20	80	100	63	162	7	40	11	23	12,5	4	6201-ZZ	6201-ZZ	12*22*7	12*22*7
0,25	4	Q2E71M4A	Aluminium	138	253	1xM20	90	112	71	190	7	45	14	30	16,0	5	6202-ZZ	6202-ZZ	15*24*5	15*24*5
0,37	2	Q2E71M2A	Aluminium	138	253	1xM20	90	112	71	190	7	45	14	30	16,0	5	6202-ZZ	6202-ZZ	15*24*5	15*24*5
0,37	4	Q2E71M4B	Aluminium	138	253	1xM20	90	112	71	190	7	45	14	30	16,0	5	6202-ZZ	6202-ZZ	15*24*5	15*24*5
0,55	2	Q2E71M2B	Aluminium	138	253	1xM20	90	112	71	190	7	45	14	30	16,0	5	6202-ZZ	6202-ZZ	15*24*5	15*24*5
0,55	4	Q2H80M4B	Aluminium	158	268	1xM20	100	125	80	216	10	50	19	40	21,5	6	6204-ZZ	6204-ZZ	20*30*7	20*30*7
0,75	2	Q2H80M2B	Aluminium	158	268	1xM20	100	125	80	216	10	50	19	40	21,5	6	6204-ZZ	6204-ZZ	20*30*7	20*30*7
0,75	4	Q2H80M4C	Aluminium	158	268	1xM20	100	125	80	216	10	50	19	40	21,5	6	6204-ZZ	6204-ZZ	20*30*7	20*30*7
0,75	6	Q2H90S6B	Aluminium	172	344	1xM25	100-125	140	90	223	10	56	24	50	27,0	8	6305-ZZ	6205-ZZ	25*40*7	25*40*7
1,1	2	Q2H80M2C	Aluminium	158	268	1xM20	100	125	80	216	10	50	19	40	21,5	6	6204-ZZ	6204-ZZ	20*30*7	20*30*7
1,1	4	Q2H90L4C	Aluminium	158	278	1xM25	100-125	140	90	213	10	56	24	50	27,0	8	6305-ZZ	6204-ZZ	25*40*7	20*30*7
1,1	6	Q2H90L6C	Aluminium	172	344	1xM25	100-125	140	90	223	10	56	24	50	27,0	8	6305-ZZ	6205-ZZ	25*40*7	25*40*7
1,5	2	Q2H90L2B	Aluminium	158	278	1xM25	100-125	140	90	213	10	56	24	50	27,0	8	6305-ZZ	6204-ZZ	25*40*7	20*30*7
1,5	4	Q2H90L4C	Aluminium	158	303	1xM25	100-125	140	90	213	10	56	24	50	27,0	8	6305-ZZ	6204-ZZ	25*40*7	20*30*7
1,5	6	Q2H100L6C	Aluminium	191	400	1xM25	140	160	100	243	12	63	28	60	31,0	8	6306-ZZ	6205-ZZ	30*47*7	30*47*7
2,2	2	Q2H90L2D	Aluminium	158	303	1xM25	100-125	140	90	213	10	56	24	50	27,0	8	6305-ZZ	6204-ZZ	25*40*7	20*30*7
2,2	4	Q2H100L4B	Aluminium	172	349	1xM25	140	160	100	233	12	63	28	60	31,0	8	6306-ZZ	6205-ZZ	30*47*7	25*40*7
2,2	6	Q2H112M6C	Aluminium	210	396	1xM25	140	190	112	265	12	70	28	60	31,0	8	6306-ZZ	6206-ZZ	30*47*7	30*47*7
3	2	Q2H100L2C	Aluminium	172	349	1xM25	140	160	100	233	12	63	28	60	31,0	8	6306-ZZ	6205-ZZ	30*47*7	25*40*7
3	4	Q2H100L4C	Aluminium	172	384	1xM25	140	160	100	233	12	63	28	60	31,0	8	6306-ZZ	6205-ZZ	30*47*7	25*40*7
3	6	Q2H132S6A	Aluminium	260	481	1xM32	140-178	216	132	312	12	89	38	80	41,0	10	6208-ZZ	6208-ZZ	40*62*10	40*62*10
4	2	Q2H112M2B	Aluminium	191	399	1xM25	140	190	112	254	12	70	28	60	31,0	8	6306-ZZ	6205-ZZ	30*47*7	25*40*7
4	4	Q2H112M4C	Aluminium	191	399	1xM25	140	190	112	254	12	70	28	60	31,0	8	6306-ZZ	6205-ZZ	30*47*7	25*40*7
4	6	Q2H132M6A	Aluminium	260	481	1xM32	140-178	216	132	312	12	89	38	80	41,0	10	6208-ZZ	6208-ZZ	40*62*10	40*62*10
5,5	2	Q2H132S2B	Aluminium	210	422	1xM25	140-178	216	132	283	12	89	38	80	41,0	10	6208-ZZ	6206-ZZ	40*62*10	30*47*7
5,5	4	Q2H132S4A	Aluminium	210	422	1xM25	140-178	216	132	283	12	89	38	80	41,0	10	6208-ZZ	6206-ZZ	40*62*10	30*47*7
5,5	6	Q2H132M6B	Aluminium	260	481	1xM32	140-178	216	132	312	12	89	38	80	41,0	10	6208-ZZ	6208-ZZ	40*62*10	40*62*10

(1) Toleranslar 28 mm'ye kadar DIN EN 50347 "j6", 28 mm ve üzeri "k6" / Tolerance DIN EN 50347 "j6" up to 28mm, "k6" above 28mm
(2) DIN 6885'e göre / According to DIN 6885

Güç Power (kW)	Kutup sayısı Number of Poles	Motor Tipi Motor Type	Gövde Tipi Housing Type	Ana Boyutlar Main Dimensions			Ayaklı Motorlar Foot Mounted Motors						Mil Shaft				Rulman Bearing		Keçe Seal	
				AC	L	O	B	A	H	HD	K	C	D ⁽¹⁾	E	GA	F ⁽²⁾	Kasnak Tarafı Drive Side	Kasnak Tarafı Aksı Non drive Side	Kasnak Tarafı Drive Side	Kasnak Tarafı Aksı Non drive Side
7,5	2	Q2H132S2C	Aluminium	210	422	1xM25	140-178	216	132	283	12	89	38	80	41,0	10	6208-ZZ	6206-ZZ	40*62*10	30*47*7
7,5	4	Q2H132M4C	Aluminium	260	481	1xM32	140-178	216	132	312	12	89	38	80	41,0	10	6208-ZZ	6208-ZZ	40*62*10	40*62*10
7,5	6	Q2H160M6B	Aluminium	305	591	1xM32	210-254	254	160	368	14,5	108	42	110	45,0	12	6309-ZZ	6209-ZZ	45*72*10	45*72*10
11	2	Q2H160M2B	Aluminium	260	520	1xM32	210-254	254	160	351	14,5	108	42	110	45,0	12	6309-ZZ	6208-ZZ	45*72*10	40*62*10
11	4	Q2H160M4C	Aluminium	260	520	1xM32	210-254	254	160	351	14,5	108	42	110	45,0	12	6309-ZZ	6208-ZZ	45*72*10	40*62*10
11	6	Q2H160L6B	Aluminium	305	591	1xM32	210-254	254	160	368	14,5	108	42	110	45,0	12	6309-ZZ	6209-ZZ	45*72*10	45*72*10
15	2	Q2H160M2C	Aluminium	260	520	1xM32	210-254	254	160	351	14,5	108	42	110	45,0	12	6309-ZZ	6208-ZZ	45*72*10	40*62*10
15	4	Q2H160L4B	Aluminium	260	520	1xM32	210-254	254	160	351	14,5	108	42	110	45,0	12	6309-ZZ	6208-ZZ	45*72*10	40*62*10
15	6	Q2H180L6A	Aluminium	349	696	1xM40	241-279	279	180	437	14,5	121	48	110	51,5	14	6310-ZZ	6310-ZZ	50*80*10	50*80*10
18,5	2	Q2H160M2D	Aluminium	260	520	1xM32	210-254	254	160	351	14,5	108	42	110	45,0	12	6309-ZZ	6208-ZZ	45*72*10	40*62*10
18,5	4	Q2H180M4A	Aluminium	305	596	1xM32	241-279	279	180	398	14,5	121	48	110	51,5	14	6310-ZZ	6209-ZZ	50*80*10	45*72*10
18,5	6	Q2H200L6B	Aluminium	349	706	1xM50	305	318	200	455	18,5	133	55	110	59,0	16	6312-ZZ	6310-ZZ	60*90*10	60*90*10
22	2	Q2H180M2A	Aluminium	305	596	1xM32	241-279	279	180	398	14,5	121	48	110	51,5	14	6310-ZZ	6209-ZZ	50*80*10	45*72*10
22	4	Q2H180M4B	Aluminium	305	596	1xM32	241-279	279	180	398	14,5	121	48	110	51,5	14	6310-ZZ	6209-ZZ	50*80*10	45*72*10
22	6	Q2H200L6C	Aluminium	349	706	1xM50	267-305	318	200	455	18,5	133	55	110	59,0	16	6312-ZZ	6310-ZZ	60*90*10	60*90*10
30	2	Q2H200L2B	Aluminium	349	706	1xM50	267-305	318	200	455	18,5	133	55	110	59,0	16	6312-ZZ	6310-ZZ	60*90*10	60*90*10
30	4	Q2H200L4C	Aluminium	349	706	1xM50	267-305	318	200	455	18,5	133	55	110	59,0	16	6312-ZZ	6310-ZZ	60*90*10	60*90*10
30	6	Q2E225M6B	Aluminium	456	765	1xM50	286-311	356	225	485	18,5	149	60	140	64,0	18	6313-ZZ	6313-ZZ	65*100*13	65*100*13
37	2	Q2H200L2C	Aluminium	349	706	1xM50	305	318	200	455	18,5	133	55	110	59,0	16	6312-ZZ	6310-ZZ	60*90*10	60*90*10
37	4	Q2E225M4A	Aluminium	456	765	1xM50	286-311	356	225	485	18,5	149	60	140	64,0	18	6313-ZZ	6313-ZZ	65*100*13	65*100*13
45	2	Q2E225M2B	Aluminium	456	735	1xM50	286-311	356	225	485	18,5	149	55	110	59,0	16	6313-ZZ	6313-ZZ	65*100*13	65*100*13
45	4	Q2E225M4B	Aluminium	456	765	1xM50	286-311	356	225	485	18,5	149	60	140	64,0	18	6313-ZZ	6313-ZZ	65*100*13	65*100*13
55	2	Q2E250M2A	Aluminium	527	886	2*M50	349	406	250	615	24	149	60	140	64,0	18	6315-ZZ	6313-ZZ	75*112*12	65*100*13
55	2	Q2E250M2A	Cast Iron	489	893	1xM50	349	406	250	616	24	149	60	140	69,0	18	6316-Z	6316-Z	80*100*10	80*100*10
55	4	Q2E250M4A	Cast Iron	489	893	1xM50	349	406	250	616	24	149	65	140	69,0	18	6316-Z	6316-Z	80*100*10	80*100*10
75	2	Q2EP280M2B	Cast Iron	489	1025	1xM50	419	457	280	647	24	190	65	140	69,0	18	6316-Z	6316-Z	80*100*10	80*100*10
75	4	Q2EP280M4B	Cast Iron	489	1025	1xM50	419	457	280	647	24	190	75	140	79,5	20	6316-Z	6316-Z	80*100*10	80*100*10
90	2	Q2EP280M2C	Cast Iron	489	1025	1xM50	419	457	280	647	24	190	65	140	69,0	18	6316-Z	6316-Z	80*100*10	80*100*10
90	4	Q2EP280M4C	Cast Iron	489	1025	1xM50	419	457	280	647	24	190	75	140	79,5	20	6316-Z	6316-Z	80*100*10	80*100*10
110	2	Q2EP315S2C	Cast Iron	630	1180	2*M63	406	508	315	845	28	216	65	140	69	18	6317	6317	85*105*5,5	85*105*5,5
110	4	Q2EP315S4C	Cast Iron	630	1210	2*M63	406	508	315	845	28	216	80	170	85	22	6319	6319	95*115*5,5	95*115*5,5
132	2	Q2EP315M2C	Cast Iron	630	1290	2*M63	457	508	315	845	28	216	65	140	69	18	6317	6317	85*105*5,5	85*105*5,5
132	4	Q2EP315M4C	Cast Iron	630	1320	2*M63	457	508	315	845	28	216	80	170	85	22	6319	6319	95*115*5,5	95*115*5,5
160	2	Q2EP315L2C	Cast Iron	630	1290	2*M63	508	508	315	845	28	216	65	140	69	18	6317	6317	85*105*5,5	85*105*5,5
160	4	Q2EP315L4C	Cast Iron	630	1320	2*M63	508	508	315	845	28	216	80	170	85	22	6319	6319	95*115*5,5	95*115*5,5
200	2	Q2EP315L2D	Cast Iron	630	1290	2*M63	508	508	315	845	28	216	65	140	69	18	6317	6317	85*105*5,5	85*105*5,5
200	4	Q2EP315L4D	Cast Iron	630	1320	2*M63	508	508	315	845	28	216	80	170	85	22	6319	6319	95*115*5,5	95*115*5,5
250	2	Q2EP355M2C	Cast Iron	710	1486	4*M63	560	610	355	956	28	254	75	140	80	20	6317	6317	85*105*5,5	85*105*5,5
250	4	Q2EP355M4C	Cast Iron	710	1517	4*M63	560	610	355	956	28	254	95	170	100	25	6322	6322	110*130*5,5	110*130*5,5
315	2	Q2EP355L2C	Cast Iron	710	1486	4*M63	630	610	355	956	28	254	75	140	80	20	6317	6317	85*105*5,5	85*105*5,5
315	4	Q2EP355L4C	Cast Iron	710	1517	4*M63	630	610	355	956	28	254	95	170	100	25	6322	6322	110*130*5,5	110*130*5,5
355	2	Q2EP355L2D	Cast Iron	710	1486	4*M63	630	610	355	956	28	254	75	140	80	20	6317	6317	85*105*5,5	85*105*5,5
355	4	Q2EP355L4D	Cast Iron	710	1517	4*M63	630	610	355	956	28	254	95	170	100	25	6322	6322	110*130*5,5	110*130*5,5

(1) Toleranslar 28 mm'ye kadar DIN EN 50347 "j6", 28 mm ve üzeri "k6" / Tolerance DIN EN 50347 "j6" up to 28mm, "k6" above 28mm
(2) DIN 6885'e göre / According to DIN 6885

BOYUTLAR - B5, B35 / DIMENSION - B5, B35

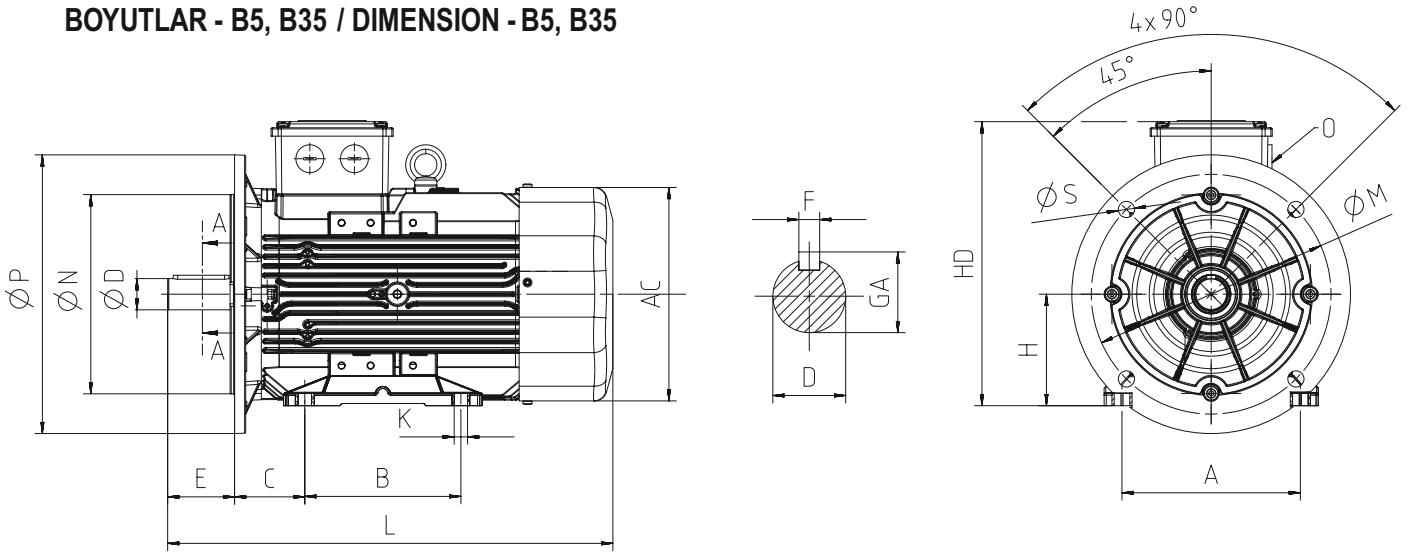

Güç Power (kW)	Kutup sayısı Number of Poles	Motor Tipi Motor Type	Gövde Tipi Housing Type	Ana Boyutlar Main Dimensions			Ayaklı Motorlar Foot Mounted Motors					Mil Shaft				Rulman Bearing		Keçe Seal		Flanş (FA) (B5) Flange (FA) (B5)				
				AC	L	O	B	A	H	HD	K	D ⁽¹⁾	E	GA	F ⁽²⁾	Kasnak Taraflı Drive Side	Kasnak Taraflı Aksı Non drive Side	Kasnak Taraflı Drive Side	Kasnak Taraflı Aksı Non drive Side	P	N ⁽³⁾	M	R	S
0,12	4	Q2E63M4A	Aluminium	123	220	1xM20	80	100	63	162	7	11	23	12,5	4	6201-ZZ	6201-ZZ	12*22*7	12*22*7	140	95	115	-	10
0,18	2	Q2E63M2A	Aluminium	123	220	1xM20	80	100	63	162	7	11	23	12,5	4	6201-ZZ	6201-ZZ	12*22*7	12*22*7	140	95	115	-	10
0,18	4	Q2E63M4B	Aluminium	123	220	1xM20	80	100	63	162	7	11	23	12,5	4	6201-ZZ	6201-ZZ	12*22*7	12*22*7	140	95	115	-	10
0,25	2	Q2E63M2B	Aluminium	123	220	1xM20	80	100	63	162	7	11	23	12,5	4	6201-ZZ	6201-ZZ	12*22*7	12*22*7	140	95	115	-	10
0,25	4	Q2E71M4A	Aluminium	138	253	1xM20	90	112	71	190	7	14	30	16,0	5	6202-ZZ	6202-ZZ	15*24*5	15*24*5	160	110	130	-	10
0,37	2	Q2E71M2A	Aluminium	138	253	1xM20	90	112	71	190	7	14	30	16,0	5	6202-ZZ	6202-ZZ	15*24*5	15*24*5	160	110	130	-	10
0,37	4	Q2E71M4B	Aluminium	138	253	1xM20	90	112	71	190	7	14	30	16,0	5	6202-ZZ	6202-ZZ	15*24*5	15*24*5	160	110	130	-	10
0,55	2	Q2E71M2B	Aluminium	138	253	1xM20	90	112	71	190	7	14	30	16,0	5	6202-ZZ	6202-ZZ	15*24*5	15*24*5	160	110	130	-	10
0,55	4	Q2H80M4B	Aluminium	158	268	1xM20	100	125	80	216	10	19	40	21,5	6	6204-ZZ	6204-ZZ	20*30*7	20*30*7	200	130	165	-	12
0,75	2	Q2H80M2B	Aluminium	158	268	1xM20	100	125	80	216	10	19	40	21,5	6	6204-ZZ	6204-ZZ	20*30*7	20*30*7	200	130	165	-	12
0,75	4	Q2H80M4C	Aluminium	158	268	1xM20	100	125	80	216	10	19	40	21,5	6	6204-ZZ	6204-ZZ	20*30*7	20*30*7	200	130	165	-	12
0,75	6	Q2H90S6B	Aluminium	172	344	1xM25	100-125	140	90	223	10	24	50	27,0	8	6305-ZZ	6205-ZZ	25*40*7	25*40*7	200	130	165	-	12
1,1	2	Q2H80M2C	Aluminium	158	268	1xM20	100	125	80	216	10	19	40	21,5	6	6204-ZZ	6204-ZZ	20*30*7	20*30*7	200	130	165	-	12
1,1	4	Q2H90L4C	Aluminium	158	278	1xM25	100-125	140	90	213	10	24	50	27,0	8	6305-ZZ	6204-ZZ	25*40*7	20*30*7	200	130	165	-	12
1,1	6	Q2H90L6B	Aluminium	172	344	1xM25	100-125	140	90	223	10	24	50	27,0	8	6305-ZZ	6205-ZZ	25*40*7	25*40*7	200	130	165	-	12
1,5	2	Q2H90L2B	Aluminium	158	278	1xM25	100-125	140	90	213	10	24	50	27,0	8	6305-ZZ	6204-ZZ	25*40*7	20*30*7	200	130	165	-	12
1,5	4	Q2H90L4C	Aluminium	158	303	1xM25	100-125	140	90	213	10	24	50	27,0	8	6305-ZZ	6204-ZZ	25*40*7	20*30*7	200	130	165	-	12
1,5	6	Q2H100L6C	Aluminium	191	400	1xM25	140	160	100	243	12	28	60	31,0	8	6306-ZZ	6205-ZZ	30*47*7	30*47*7	250	180	215	-	14,5
2,2	2	Q2H90L2D	Aluminium	158	303	1xM25	100-125	140	90	213	10	24	50	27,0	8	6305-ZZ	6204-ZZ	25*40*7	20*30*7	200	130	165	-	12
2,2	4	Q2H100L4B	Aluminium	172	349	1xM25	140	160	100	233	12	28	60	31,0	8	6306-ZZ	6205-ZZ	30*47*7	25*40*7	250	180	215	-	14,5
2,2	6	Q2H112M6C	Aluminium	210	396	1xM25	140	190	112	265	12	28	60	31,0	8	6306-ZZ	6206-ZZ	30*47*7	30*47*7	250	180	215	-	14,5
3	2	Q2H100L2C	Aluminium	172	349	1xM25	140	160	100	233	12	28	60	31,0	8	6306-ZZ	6205-ZZ	30*47*7	25*40*7	250	180	215	-	14,5
3	4	Q2H100L4C	Aluminium	172	384	1xM25	140	160	100	233	12	28	60	31,0	8	6306-ZZ	6205-ZZ	30*47*7	25*40*7	250	180	215	-	14,5
3	6	Q2H132S6A	Aluminium	260	481	1xM32	140-178	216	132	312	12	38	80	41,0	10	6208-ZZ	6208-ZZ	40*62*10	40*62*10	300	230	265	-	14,5
4	2	Q2H112M2B	Aluminium	191	399	1xM25	140	190	112	254	12	28	60	31,0	8	6306-ZZ	6205-ZZ	30*47*7	25*40*7	250	180	215	-	14,5
4	4	Q2H112M4C	Aluminium	191	399	1xM25	140	190	112	254	12	28	60	31,0	8	6306-ZZ	6205-ZZ	30*47*7	25*40*7	250	180	215	-	14,5
4	6	Q2H132M6A	Aluminium	260	481	1xM32	140-178	216	132	312	12	38	80	41,0	10	6208-ZZ	6208-ZZ	40*62*10	40*62*10	300	230	265	-	14,5
5,5	2	Q2H132S2B	Aluminium	210	422	1xM25	140-178	216	132	283	12	38	80	41,0	10	6208-ZZ	6206-ZZ	40*62*10	30*47*7	300	230	265	-	14,5
5,5	4	Q2H132S4A	Aluminium	210	422	1xM25	140-178	216	132	283	12	38	80	41,0	10	6208-ZZ	6206-ZZ	40*62*10	30*47*7	300	230	265	-	14,5
5,5	6	Q2H132M6B	Aluminium	260	481	1xM32	140-178	216	132	312	12	38	80	41,0	10	6208-ZZ	6208-ZZ	40*62*10	40*62*10	300	230	265	-	14,5

(1) Toleranslar 28 mm'ye kadar DIN EN 50347 "j6", 28 mm ve üzeri "k6" / Tolerance DIN EN 50347 "j6" up to 28mm, "k6" above 28mm

(2) DIN 6885'e göre / According to DIN 6885

(3) Tolerans DIN EN 50347 "j6" / Tolerance DIN EN 50347 "j6"

Güç Power (kW)	Kutup sayısı Number of Poles	Motor Tipi Motor Type	Gövde Tipi Housing Type	Ana Boyutlar Main Dimensions			Ayaklı Motorlar Foot Mounted Motors					Mil Shaft			Rulman Bearing		Keçe Seal		Flanş (FA) (B5) Flange (FA) (B5)					
				AC	L	O	B	A	H	HD	K	D ⁽¹⁾	E	GA	F ⁽²⁾	Kasnak Taraflı Drive Side	Kasnak Taraflı Non drive Side	Kasnak Taraflı Drive Side	Kasnak Taraflı Non drive Side	P	N ⁽³⁾	M	R	S
7,5	2	Q2H132S2C	Aluminium	210	422	1xM25	140-178	216	132	283	12	38	80	41,0	10	6208-ZZ	6206-ZZ	40*62*10	30*47*7	300	230	265	-	14,5
7,5	4	Q2H132M4C	Aluminium	260	481	1xM32	140-178	216	132	312	12	38	80	41,0	10	6208-ZZ	6208-ZZ	40*62*10	40*62*10	300	230	265	-	14,5
7,5	6	Q2H160M6B	Aluminium	305	591	1xM32	210-254	254	160	368	14,5	42	110	45,0	12	6309-ZZ	6209-ZZ	45*72*10	45*72*10	350	250	300	-	18,5
11	2	Q2H160M2B	Aluminium	260	520	1xM32	210-254	254	160	351	14,5	42	110	45,0	12	6309-ZZ	6208-ZZ	45*72*10	40*62*10	350	250	300	-	18,5
11	4	Q2H160M4C	Aluminium	260	520	1xM32	210-254	254	160	351	14,5	42	110	45,0	12	6309-ZZ	6208-ZZ	45*72*10	40*62*10	350	250	300	-	18,5
11	6	Q2H160L6B	Aluminium	305	591	1xM32	210-254	254	160	368	14,5	42	110	45,0	12	6309-ZZ	6209-ZZ	45*72*10	45*72*10	350	250	300	-	18,5
15	2	Q2H160M2C	Aluminium	260	520	1xM32	210-254	254	160	351	14,5	42	110	45,0	12	6309-ZZ	6208-ZZ	45*72*10	40*62*10	350	250	300	-	18,5
15	4	Q2H160L4B	Aluminium	260	520	1xM32	210-254	254	160	351	14,5	42	110	45,0	12	6309-ZZ	6208-ZZ	45*72*10	40*62*10	350	250	300	-	18,5
15	6	Q2H180L6A	Aluminium	349	696	1xM40	241-279	279	180	437	14,5	48	110	51,5	14	6310-ZZ	6310-ZZ	50*80*10	50*80*10	350	250	300	-	18,5
18,5	2	Q2H160M2D	Aluminium	260	520	1xM32	210-254	254	160	351	14,5	42	110	45,0	12	6309-ZZ	6208-ZZ	45*72*10	40*62*10	350	250	300	-	18,5
18,5	4	Q2H180M4A	Aluminium	305	596	1xM32	241-279	279	180	398	14,5	48	110	51,5	14	6310-ZZ	6209-ZZ	50*80*10	45*72*10	350	250	300	-	18,5
18,5	6	Q2H200L6B	Aluminium	349	706	1xM50	305	318	200	455	18,5	55	110	59,0	16	6312-ZZ	6310-ZZ	60*90*10	60*90*10	400	300	350	-	18,5
22	2	Q2H180M2A	Aluminium	305	596	1xM32	241-279	279	180	398	14,5	48	110	51,5	14	6310-ZZ	6209-ZZ	50*80*10	45*72*10	350	250	300	-	18,5
22	4	Q2H180M4B	Aluminium	305	596	1xM32	241-279	279	180	398	14,5	48	110	51,5	14	6310-ZZ	6209-ZZ	50*80*10	45*72*10	350	250	300	-	18,5
22	6	Q2H200L6C	Aluminium	349	706	1xM50	267-305	318	200	455	18,5	55	110	59,0	16	6312-ZZ	6310-ZZ	60*90*10	60*90*10	400	300	350	-	18,5
30	2	Q2H200L2B	Aluminium	349	706	1xM50	267-305	318	200	455	18,5	55	110	59,0	16	6312-ZZ	6310-ZZ	60*90*10	60*90*10	400	300	350	-	18,5
30	4	Q2H200L4C	Aluminium	349	706	1xM50	267-305	318	200	455	18,5	55	110	59,0	16	6312-ZZ	6310-ZZ	60*90*10	60*90*10	400	300	350	-	18,5
30	6	Q2E225M6B	Aluminium	456	765	1xM50	286-311	356	225	485	18,5	60	140	64,0	18	6313-ZZ	6313-ZZ	65*100*13	65*100*13	450	350	400	-	18,5
37	2	Q2H200L2C	Aluminium	349	706	1xM50	267-305	318	200	455	18,5	55	110	59,0	16	6312-ZZ	6310-ZZ	60*90*10	60*90*10	400	300	350	-	18,5
37	4	Q2E225M4A	Aluminium	456	765	1xM50	286-311	356	225	485	18,5	60	140	64,0	18	6313-ZZ	6313-ZZ	65*100*13	65*100*13	450	350	400	-	18,5
45	2	Q2E225M2B	Aluminium	456	735	1xM50	286-311	356	225	485	18,5	55	110	59,0	16	6313-ZZ	6313-ZZ	65*100*13	65*100*13	450	350	400	-	18,5
45	4	Q2E225M4B	Aluminium	456	765	1xM50	286-311	356	225	485	18,5	60	140	64,0	18	6313-ZZ	6313-ZZ	65*100*13	65*100*13	450	350	400	-	18,5
55	2	Q2E250M2A	Aluminium	527	886	2*M50	349	406	250	615	24	60	140	18	64	6315-ZZ	6313-ZZ	75*112*12	65*100*13	550	450	500	-	18,5
55	2	Q2E250M2A	Cast Iron	489	893	1xM50	349	406	250	616	24	60	140	69,0	18	6316-Z	6316-Z	80*100*10	80*100*10	550	450	500	-	18,5
55	4	Q2E250M4A	Cast Iron	489	893	1xM50	349	406	250	616	24	65	140	69,0	18	6316-Z	6316-Z	80*100*10	80*100*10	550	450	500	-	18,5
75	2	Q2EP280M2B	Cast Iron	489	1025	1xM50	419	457	280	647	24	65	140	69,0	18	6316-Z	6316-Z	80*100*10	80*100*10	550	450	500	-	18,5
75	4	Q2EP280M4B	Cast Iron	489	1025	1xM50	419	457	280	647	24	75	140	79,5	20	6316-Z	6316-Z	80*100*10	80*100*10	550	450	500	-	18,5
90	2	Q2EP280M2C	Cast Iron	489	1025	1xM50	419	457	280	647	24	65	140	69,0	18	6316-Z	6316-Z	80*100*10	80*100*10	550	450	500	-	18,5
90	4	Q2EP280M4C	Cast Iron	489	1025	1xM50	419	457	280	647	24	75	140	79,5	20	6316-Z	6316-Z	80*100*10	80*100*10	550	450	500	-	18,5
110	2	Q2EP315S2C	Cast Iron	630	1180	2*M63	406	508	315	845	28	216	65	140	69	6317	6317	85*105*5,5	85*105*5,5	660	550	600	-	24
110	4	Q2EP315S4C	Cast Iron	630	1210	2*M63	406	508	315	845	28	216	80	170	85	6319	6319	95*115*5,5	95*115*5,5	660	550	600	-	24
132	2	Q2EP315M2C	Cast Iron	630	1290	2*M63	457	508	315	845	28	216	65	140	69	6317	6317	85*105*5,5	85*105*5,5	660	550	600	-	24
132	4	Q2EP315M4C	Cast Iron	630	1320	2*M63	457	508	315	845	28	216	80	170	85	6319	6319	95*115*5,5	95*115*5,5	660	550	600	-	24
160	2	Q2EP315L2C	Cast Iron	630	1290	2*M63	508	508	315	845	28	216	65	140	69	6317	6317	85*105*5,5	85*105*5,5	660	550	600	-	24
160	4	Q2EP315L4C	Cast Iron	630	1320	2*M63	508	508	315	845	28	216	80	170	85	6319	6319	95*115*5,5	95*115*5,5	660	550	600	-	24
200	2	Q2EP315L2D	Cast Iron	630	1290	2*M63	508	508	315	845	28	216	65	140	69	6317	6317	85*105*5,5	85*105*5,5	660	550	600	-	24
200	4	Q2EP315L4D	Cast Iron	630	1320	2*M63	508	508	315	845	28	216	80	170	85	6319	6319	95*115*5,5	95*115*5,5	660	550	600	-	24
250	2	Q2EP355M2C	Cast Iron	710	1486	4*M63	560	610	355	956	28	254	75	140	80	6317	6317	85*105*5,5	85*105*5,5	800	680	740	-	24
250	4	Q2EP355M4C	Cast Iron	710	1517	4*M63	560	610	355	956	28	254	95	170	100	6322	6322	110*130*5,5	110*130*5,5	800	680	740	-	24
315	2	Q2EP355L2C	Cast Iron	710	1486	4*M63	630	610	355	956	28	254	75	140	80	6317	6317	85*105*5,5	85*105*5,5	800	680	740	-	24
315	4	Q2EP355L4C	Cast Iron	710	1517	4*M63	630	610	355	956	28	254	95	170	100	6322	6322	110*130*5,5	110*130*5,5	800	680	740	-	24
355	2	Q2EP355L2D	Cast Iron	710	1486	4*M63	630	610	355	956	28	254	75	140	80	6317	6317	85*105*5,5	85*105*5,5	800	680	740	-	24
355	4	Q2EP355L4D	Cast Iron	710	1517	4*M63	630	610	355	956	28	254	95	170	100	6322	6322	110*130*5,5	110*130*5,5	800	680	740	-	24

BOYUTLAR - B14a, B34a / DIMENSION - B14a, B34a

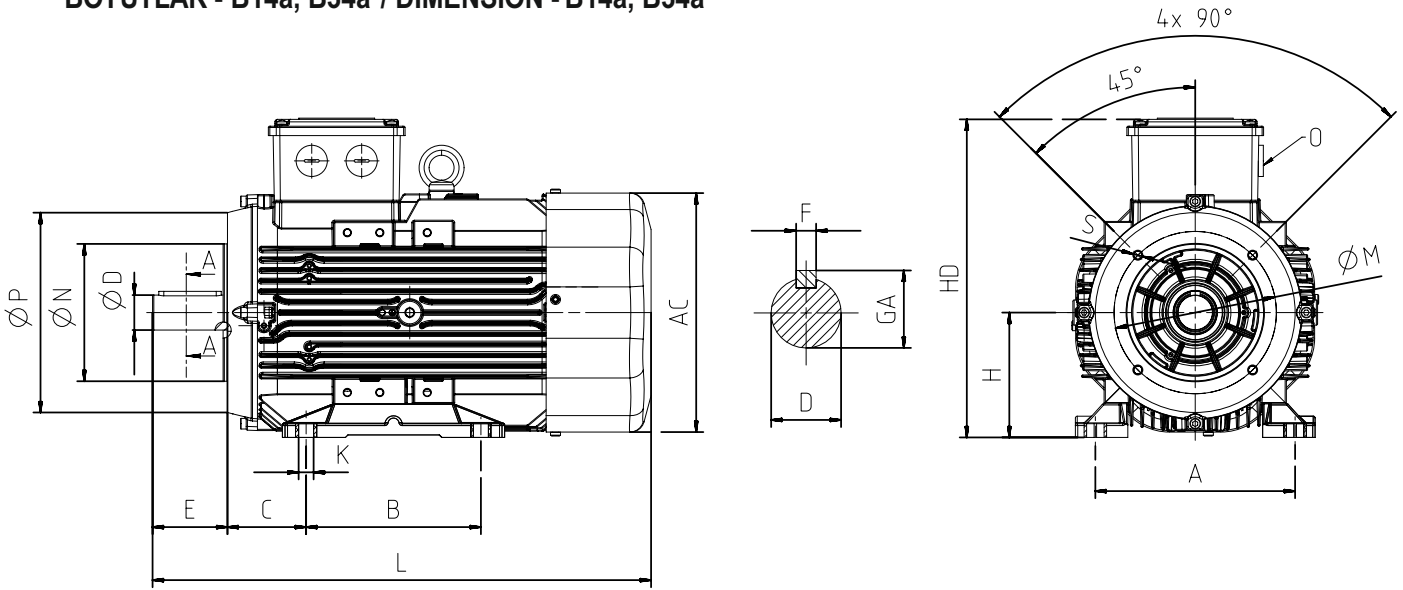

Güç Power (kW)	Kutup sayısı Number of Poles	Motor Tipi Motor Type	Gövde Tipi Housing Type	Ana Boyutlar Main Dimensions			Ayaklı Motorlar Foot Mounted Motors					Mil Shaft		Rulman Bearing		Keçe Seal		Flanş (FC) (B14a) Flange (FC) (B14a)						
				AC	L	O	B	A	H	HD	K	D ⁽¹⁾	E	GA	F ⁽²⁾	Kasnak Tarafı Drive Side	Kasnak Tarafı Aksı Non drive Side	Kasnak Tarafı Drive Side	Kasnak Tarafı Aksı Non drive Side	P	N ⁽³⁾	M	R	S
0,12	4	Q2E63M4A	Aluminium	123	220	1xM20	80	100	63	162	7	11	23	12,5	4	6201-ZZ	6201-ZZ	12*22*7	12*22*7	90	60	75	-	M5
0,18	2	Q2E63M2A	Aluminium	123	220	1xM20	80	100	63	162	7	11	23	12,5	4	6201-ZZ	6201-ZZ	12*22*7	12*22*7	90	60	75	-	M5
0,18	4	Q2E63M4B	Aluminium	123	220	1xM20	80	100	63	162	7	11	23	12,5	4	6201-ZZ	6201-ZZ	12*22*7	12*22*7	90	60	75	-	M5
0,25	2	Q2E63M2B	Aluminium	123	220	1xM20	80	100	63	162	7	11	23	12,5	4	6201-ZZ	6201-ZZ	12*22*7	12*22*7	90	60	75	-	M5
0,25	4	Q2E71M4A	Aluminium	138	253	1xM20	90	112	71	190	7	14	30	16,0	5	6202-ZZ	6202-ZZ	15*24*5	15*24*5	105	70	85	-	M6
0,37	2	Q2E71M2A	Aluminium	138	253	1xM20	90	112	71	190	7	14	30	16,0	5	6202-ZZ	6202-ZZ	15*24*5	15*24*5	105	70	85	-	M6
0,37	4	Q2E71M4B	Aluminium	138	253	1xM20	90	112	71	190	7	14	30	16,0	5	6202-ZZ	6202-ZZ	15*24*5	15*24*5	105	70	85	-	M6
0,55	2	Q2E71M2B	Aluminium	138	253	1xM20	90	112	71	190	7	14	30	16,0	5	6202-ZZ	6202-ZZ	15*24*5	15*24*5	105	70	85	-	M6
0,55	4	Q2H80M4B	Aluminium	158	268	1xM20	100	125	80	216	10	19	40	21,5	6	6204-ZZ	6204-ZZ	20*30*7	20*30*7	120	80	100	-	M6
0,75	2	Q2H80M2B	Aluminium	158	268	1xM20	100	125	80	216	10	19	40	21,5	6	6204-ZZ	6204-ZZ	20*30*7	20*30*7	120	80	100	-	M6
0,75	4	Q2H80M4C	Aluminium	158	268	1xM20	100	125	80	216	10	19	40	21,5	6	6204-ZZ	6204-ZZ	20*30*7	20*30*7	120	80	100	-	M6
0,75	6	Q2H90S6B	Aluminium	172	344	1xM25	100-125	140	90	223	10	24	50	27,0	8	6305-ZZ	6205-ZZ	25*40*7	25*40*7	140	95	115	-	M8
1,1	2	Q2H80M2C	Aluminium	158	268	1xM20	100	125	80	216	10	19	40	21,5	6	6204-ZZ	6204-ZZ	20*30*7	20*30*7	120	80	100	-	M6
1,1	4	Q2H90L4C	Aluminium	158	278	1xM25	100-125	140	90	213	10	24	50	27,0	8	6305-ZZ	6204-ZZ	25*40*7	20*30*7	140	95	115	-	M8
1,1	6	Q2H90L6C	Aluminium	172	344	1xM25	100-125	140	90	223	10	24	50	27,0	8	6305-ZZ	6205-ZZ	25*40*7	25*40*7	140	95	115	-	M8
1,5	2	Q2H90L2B	Aluminium	158	278	1xM25	100-125	140	90	213	10	24	50	27,0	8	6305-ZZ	6204-ZZ	25*40*7	20*30*7	140	95	115	-	M8
1,5	4	Q2H90L4C	Aluminium	158	303	1xM25	100-125	140	90	213	10	24	50	27,0	8	6305-ZZ	6204-ZZ	25*40*7	20*30*7	140	95	115	-	M8
1,5	6	Q2H100L6C	Aluminium	191	400	1xM25	140	160	100	243	12	28	60	31,0	8	6306-ZZ	6205-ZZ	30*47*7	30*47*7	160	110	130	-	M8
2,2	2	Q2H90L2D	Aluminium	158	303	1xM25	100-125	140	90	213	10	24	50	27,0	8	6305-ZZ	6204-ZZ	25*40*7	20*30*7	140	95	115	-	M8
2,2	4	Q2H100L4B	Aluminium	172	349	1xM25	140	160	100	233	12	28	60	31,0	8	6306-ZZ	6205-ZZ	30*47*7	25*40*7	160	110	130	-	M8
2,2	6	Q2H112M6C	Aluminium	210	396	1xM25	140	190	112	265	12	28	60	31,0	8	6306-ZZ	6206-ZZ	30*47*7	30*47*7	160	110	130	-	M8
3	2	Q2H100L2C	Aluminium	172	349	1xM25	140	160	100	233	12	28	60	31,0	8	6306-ZZ	6205-ZZ	30*47*7	25*40*7	160	110	130	-	M8
3	4	Q2H100L4C	Aluminium	172	384	1xM25	140	160	100	233	12	28	60	31,0	8	6306-ZZ	6205-ZZ	30*47*7	25*40*7	160	110	130	-	M8
3	6	Q2H132S6A	Aluminium	260	481	1xM32	140-178	216	132	312	12	38	80	41,0	10	6208-ZZ	6208-ZZ	40*62*10	40*62*10	200	130	165	-	M10
4	2	Q2H112M2B	Aluminium	191	399	1xM25	140	190	112	254	12	28	60	31,0	8	6306-ZZ	6205-ZZ	30*47*7	25*40*7	160	110	130	-	M8
4	4	Q2H112M4C	Aluminium	191	399	1xM25	140	190	112	254	12	28	60	31,0	8	6306-ZZ	6205-ZZ	30*47*7	25*40*7	160	110	130	-	M8
4	6	Q2H132M6A	Aluminium	260	481	1xM32	140-178	216	132	312	12	38	80	41,0	10	6208-ZZ	6208-ZZ	40*62*10	40*62*10	200	130	165	-	M10
5,5	2	Q2H132S2B	Aluminium	210	422	1xM25	140-178	216	132	283	12	38	80	41,0	10	6208-ZZ	6206-ZZ	40*62*10	30*47*7	200	130	165	-	M10
5,5	4	Q2H132S4A	Aluminium	210	422	1xM25	140-178	216	132	283	12	38	80	41,0	10	6208-ZZ	6206-ZZ	40*62*10	30*47*7	200	130	165	-	M10
5,5	6	Q2H132M6B	Aluminium	260	481	1xM32	140-178	216	132	312	12	38	80	41,0	10	6208-ZZ	6208-ZZ	40*62*10	40*62*10	200	130	165	-	M10
7,5	2	Q2H132S2C	Aluminium	210	422	1xM25	140-178	216	132	283	12	38	80	41,0	10	6208-ZZ	6206-ZZ	40*62*10	30*47*7	200	130	165	-	M10
7,5	4	Q2H132M4C	Aluminium	260	481	1xM32	140-178	216	132	312	12	38	80	41,0	10	6208-ZZ	6208-ZZ	40*62*10	40*62*10	200	130	165	-	M10

(1) Toleranslar 28 mm'ye kadar DIN EN 50347 "j6", 28 mm ve üzeri "k6" / Tolerance DIN EN 50347 "j6" up to 28mm, "k6" above 28mm

(2) DIN 6885'e göre / According to DIN 6885

(3) Tolerans DIN EN 50347 "j6" / Tolerance DIN EN 50347 "j6"

BOYUTLAR - B14b, B34b / DIMENSION - B14b, B34b

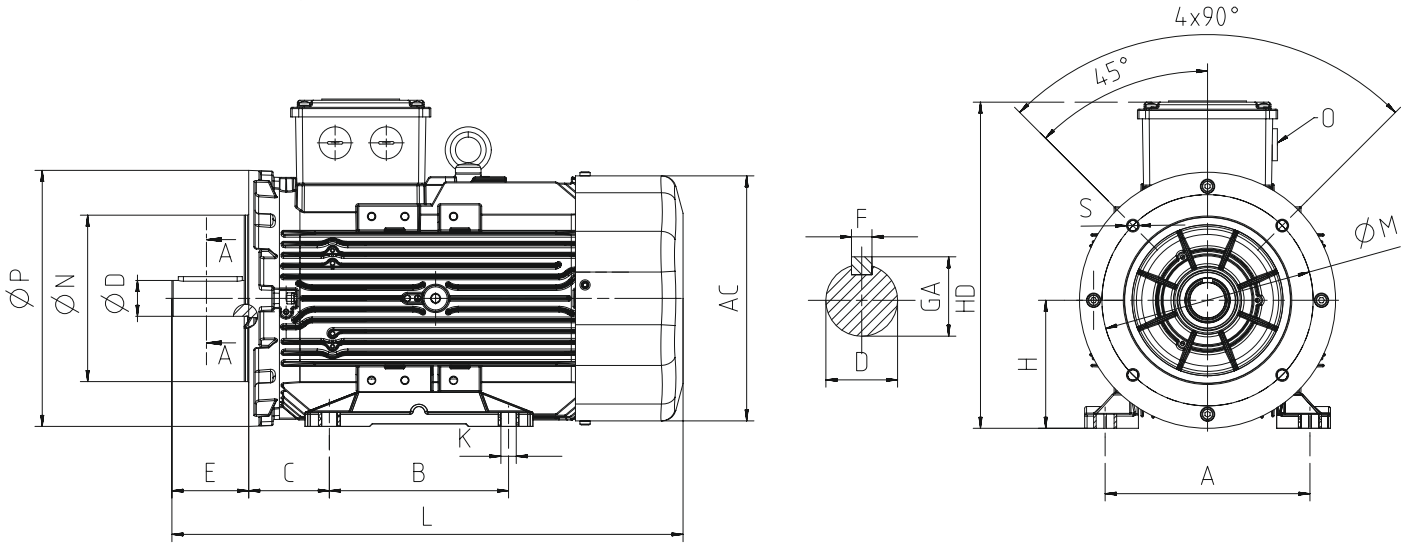

Güç Power (kW)	Kutup sayısı Number of Poles	Motor Tipi Motor Type	Gövde Tipi Housing Type	Ana Boyutlar Main Dimensions			Ayaklı Motorlar Foot Mounted Motors					Mil Shaft		Rulman Bearing		Keçe Seal		Flanş (FB) (B14b) Flange (FB) (B14b)						
				AC	L	O	B	A	H	HD	K	D ⁽¹⁾	E	GA	F ⁽²⁾	Kasnak Tarafı Drive Side	Kasnak Tarafı Aksı Non drive Side	Kasnak Tarafı Drive Side	Kasnak Tarafı Aksı Non drive Side	P	N ⁽³⁾	M	R	S
0,12	4	Q2E63M4A	Aluminium	123	220	1xM20	80	100	63	162	7	11	23	12,5	4	6201-ZZ	6201-ZZ	12*22*7	12*22*7	120	80	100	-	M6
0,18	2	Q2E63M2A	Aluminium	123	220	1xM20	80	100	63	162	7	11	23	12,5	4	6201-ZZ	6201-ZZ	12*22*7	12*22*7	120	80	100	-	M6
0,18	4	Q2E63M4B	Aluminium	123	220	1xM20	80	100	63	162	7	11	23	12,5	4	6201-ZZ	6201-ZZ	12*22*7	12*22*7	120	80	100	-	M6
0,25	2	Q2E63M2B	Aluminium	123	220	1xM20	80	100	63	162	7	11	23	12,5	4	6201-ZZ	6201-ZZ	12*22*7	12*22*7	120	80	100	-	M6
0,25	4	Q2E71M4A	Aluminium	138	253	1xM20	90	112	71	190	7	14	30	16,0	5	6202-ZZ	6202-ZZ	15*24*5	15*24*5	140	95	115	-	M8
0,37	2	Q2E71M2A	Aluminium	138	253	1xM20	90	112	71	190	7	14	30	16,0	5	6202-ZZ	6202-ZZ	15*24*5	15*24*5	140	95	115	-	M8
0,37	4	Q2E71M4B	Aluminium	138	253	1xM20	90	112	71	190	7	14	30	16,0	5	6202-ZZ	6202-ZZ	15*24*5	15*24*5	140	95	115	-	M8
0,55	2	Q2E71M2B	Aluminium	138	253	1xM20	90	112	71	190	7	14	30	16,0	5	6202-ZZ	6202-ZZ	15*24*5	15*24*5	140	95	115	-	M8
0,55	4	Q2H80M4B	Aluminium	158	268	1xM20	100	125	80	216	10	19	40	21,5	6	6204-ZZ	6204-ZZ	20*30*7	20*30*7	160	110	130	-	M8
0,75	2	Q2H80M2B	Aluminium	158	268	1xM20	100	125	80	216	10	19	40	21,5	6	6204-ZZ	6204-ZZ	20*30*7	20*30*7	160	110	130	-	M8
0,75	4	Q2H80M4C	Aluminium	158	268	1xM20	100	125	80	216	10	19	40	21,5	6	6204-ZZ	6204-ZZ	20*30*7	20*30*7	160	110	130	-	M8
0,75	6	Q2H90S6B	Aluminium	172	344	1xM25	100-125	140	90	223	10	24	50	27,0	8	6305-ZZ	6205-ZZ	25*40*7	25*40*7	160	110	130	-	M8
1,1	2	Q2H80M2C	Aluminium	158	268	1xM20	100	125	80	216	10	19	40	21,5	6	6204-ZZ	6204-ZZ	20*30*7	20*30*7	160	110	130	-	M8
1,1	4	Q2H90L4C	Aluminium	158	278	1xM25	100-125	140	90	213	10	24	50	27,0	8	6305-ZZ	6204-ZZ	25*40*7	20*30*7	160	110	130	-	M8
1,1	6	Q2H90L6C	Aluminium	172	344	1xM25	100-125	140	90	223	10	24	50	27,0	8	6305-ZZ	6205-ZZ	25*40*7	25*40*7	160	110	130	-	M8
1,5	2	Q2H90L2B	Aluminium	158	278	1xM25	100-125	140	90	213	10	24	50	27,0	8	6305-ZZ	6204-ZZ	25*40*7	20*30*7	160	110	130	-	M8
1,5	4	Q2H90L4C	Aluminium	158	303	1xM25	100-125	140	90	213	10	24	50	27,0	8	6305-ZZ	6204-ZZ	25*40*7	20*30*7	160	110	130	-	M8
1,5	6	Q2H100L6C	Aluminium	191	400	1xM25	140	160	100	243	12	28	60	31,0	8	6306-ZZ	6205-ZZ	30*47*7	30*47*7	200	130	165	-	M10
2,2	2	Q2H90L2D	Aluminium	158	303	1xM25	100-125	140	90	213	10	24	50	27,0	8	6305-ZZ	6204-ZZ	25*40*7	20*30*7	160	110	130	-	M8
2,2	4	Q2H100L4B	Aluminium	172	349	1xM25	140	160	100	233	12	28	60	31,0	8	6306-ZZ	6205-ZZ	30*47*7	25*40*7	200	130	165	-	M10
2,2	6	Q2H112M6C	Aluminium	210	396	1xM25	140	190	112	265	12	28	60	31,0	8	6306-ZZ	6206-ZZ	30*47*7	30*47*7	200	130	165	-	M10
3	2	Q2H100L2C	Aluminium	172	349	1xM25	140	160	100	233	12	28	60	31,0	8	6306-ZZ	6205-ZZ	30*47*7	25*40*7	200	130	165	-	M10
3	4	Q2H100L4C	Aluminium	172	384	1xM25	140	160	100	233	12	28	60	31,0	8	6306-ZZ	6205-ZZ	30*47*7	25*40*7	200	130	165	-	M10
3	6	Q2H132S6A	Aluminium	260	481	1xM32	140-178	216	132	312	12	38	80	41,0	10	6208-ZZ	6208-ZZ	40*62*10	40*62*10	250	180	215	-	M12
4	2	Q2H112M2B	Aluminium	191	399	1xM25	140	190	112	254	12	28	60	31,0	8	6306-ZZ	6205-ZZ	30*47*7	25*40*7	200	130	165	-	M10
4	4	Q2H112M4C	Aluminium	191	399	1xM25	140	190	112	254	12	28	60	31,0	8	6306-ZZ	6205-ZZ	30*47*7	25*40*7	200	130	165	-	M10
4	6	Q2H132M6A	Aluminium	260	481	1xM32	140-178	216	132	312	12	38	80	41,0	10	6208-ZZ	6208-ZZ	40*62*10	40*62*10	250	180	215	-	M12
5,5	2	Q2H132S2B	Aluminium	210	422	1xM25	140-178	216	132	283	12	38	80	41,0	10	6208-ZZ	6206-ZZ	40*62*10	30*47*7	250	180	215	-	M12
5,5	4	Q2H132S4A	Aluminium	210	422	1xM25	140-178	216	132	283	12	38	80	41,0	10	6208-ZZ	6206-ZZ	40*62*10	30*47*7	250	180	215	-	M12
5,5	6	Q2H132M6B	Aluminium	260	481	1xM32	140-178	216	132	312	12	38	80	41,0	10	6208-ZZ	6208-ZZ	40*62*10	40*62*10	250	180	215	-	M12
7,5	2	Q2H132S2C	Aluminium	210	422	1xM25	140-178	216	132	283	12	38	80	41,0	10	6208-ZZ	6206-ZZ	40*62*10	30*47*7	250	180	215	-	M12
7,5	4	Q2H132M4C	Aluminium	260	481	1xM32	140-178	216	132	312	12	38	80	41,0	10	6208-ZZ	6208-ZZ	40*62*10	40*62*10	250	180	215	-	M12

(1) Toleranslar 28 mm'ye kadar DIN EN 50347 "j6", 28 mm ve üzeri "k6" / Tolerance DIN EN 50347 "j6" up to 28mm, "k6" above 28mm
(2) DIN 6885'e göre / According to DIN 6885
(3) Tolerans DIN EN 50347 "j6" / Tolerance DIN EN 50347 "j6"

ELEKTRİKSEL ÖZELLİKLER - 50 Hz / ELECTRICAL CHARACTERISTICS AT 50 Hz

MOTOR TİPİ MOTOR TYPE	GÖVDE TIPI HOUSING TYPE	NOMINAL RATED VALUES						KALKIŞTAKİ DEĞERLER STARTING VALUES				Devrilme Momenti Oranı Breakdown Torque Ratio Mk/ Mn	VERİM* EFFICIENCY*			Cos φ	J	Ağırlık Weight (B3)	Ses Basınç Seviyesi Sound Pressure Level dBA**
		GÜÇ POWER		DEVİR SPEED rpm	AKIM CURRENT A	MOMENT TORQUE Nm	AKIM CURRENT I_A / I_N		MOMENT TORQUE M_A / M_N		η%								
		kW	HP				λ	Δ	λ	Δ	4/4		3/4	2/4					
2 kutup 3000 d/dak / 2 pole 3000 rpm																			
230/400V	Q2H80M2D	Aluminium	1,5	2,0	2875	3,8	5,0	8,0	-	3,9	-	4,4	81,3	80,4	76,6	0,74	0,00169	12	58
	Q2H80M2DE	Aluminium	2,2	3,0	2870	4,7	7,3	9,1	-	3,9	-	4,4	83,2	82,8	81,3	0,83	0,00224	16	59
	Q2H90L2D	Aluminium	3,0	4,0	2887	6,3	9,9	7,3	-	2,4	-	2,9	84,6	85,4	84,2	0,83	0,00283	19	61
400/690V	Q2HS100L2C	Aluminium	4,0	5,5	2913	8,2	13,2	3,6	10,8	1,4	4,2	4,8	85,8	87,0	86,1	0,82	0,00381	24	66
	Q2HS112M2C	Aluminium	5,5	7,5	2910	10,6	18,1	3,6	10,9	1,3	3,8	4,5	87,0	87,5	86,2	0,86	0,00637	29	68
	Q2HS112M2D	Aluminium	7,5	10,0	2895	14,1	24,8	3,4	10,3	1,3	3,9	4,6	88,1	89,0	88,7	0,88	0,00751	30	68
	Q2H132M2A	Aluminium	11,0	15,0	2923	21,3	35,9	3,1	9,2	1,1	3,3	4,8	89,4	89,9	88,4	0,83	0,03489	57	69
	Q2H132M2B	Aluminium	15,0	20,0	2915	30,0	49,2	3,2	9,6	1,3	3,9	5,1	90,3	90,6	89,6	0,80	0,03490	65	69
	Q2H132M2C	Aluminium	18,5	25,0	2930	30,8	60,3	2,7	8,0	0,6	1,9	3,6	90,9	91,7	91,1	0,95	0,04685	77	70
	Q2H160L2C	Aluminium	22,0	30,0	2955	40,9	71,2	3,5	10,4	1,2	3,6	5,2	91,3	92,0	90,7	0,84	0,04808	96	71
	Q2H180M2B	Aluminium	30,0	37,0	2955	51,5	97,1	2,8	8,5	0,8	2,4	3,6	92,0	92,5	91,8	0,91	0,08643	128	77
	Q2H180M2C	Aluminium	37,0	50,0	2965	66,2	119,6	3,4	10,1	1,0	3,1	4,5	92,5	92,5	91,2	0,87	0,10277	145	77
	Q2H200L2D	Aluminium	45,0	60,0	2960	76,0	145,1	3,3	9,8	0,9	2,8	5,3	92,9	93,4	92,7	0,92	0,11910	166	78
	Q2E225M2C	Aluminium	55,0	75,0	2970	96,6	176,9	3,5	10,6	1,0	3,0	7,1	93,2	93,7	92,4	0,88	0,29500	244	80
	Q2EP250M2C	Cast Iron	75,0	100,0	2975	127,9	240,8	3,5	10,6	0,9	2,7	6,8	93,8	93,7	92,5	0,92	0,54000	565	81
Q2EP280M2D	Cast Iron	110,0	150,0	2980	192,0	352,4	2,6	7,7	1,0	2,9	3,4	94,1	93,9	92,9	0,88	0,70200	640	82	
4 kutup 1500 d/dak / 4 pole 1500 rpm																			
230/400V	Q2H80M4D	Aluminium	1,1	1,5	1430	2,5	7,4	5,7	-	2,2	-	2,6	81,4	82,4	81,6	0,80	0,00260	12	48
	Q2H80M4DE	Aluminium	1,5	2,0	1427	3,3	10,0	6,4	-	2,5	-	3,1	82,8	84,2	83,7	0,79	0,00306	14	48
	Q2H90L4D	Aluminium	2,2	3,0	1437	5,3	14,6	7,6	-	3,6	-	4,2	84,3	84,1	81,5	0,72	0,00526	18	52
	Q2H90L4DE	Aluminium	3,0	4,0	1440	7,4	20,0	6,5	-	3,3	-	3,7	85,5	85,3	83,0	0,70	0,00690	25	53
	Q2H100L4D	Aluminium	4,0	5,5	1440	8,7	26,6	2,7	8,0	1,1	3,2	3,8	86,6	85,7	83,5	0,78	0,01058	31	57
	Q2H112M4D	Aluminium	5,5	7,5	1445	11,6	35,5	2,7	8,0	1,0	3,0	3,8	87,7	88,3	87,3	0,79	0,01382	38	58
400/690V	Q2H132M4D	Aluminium	11,0	15,0	1468	21,6	71,5	2,6	7,9	0,7	2,1	3,6	89,8	91,1	90,3	0,81	0,05440	76	61
	Q2H132M4E	Aluminium	15,0	20,0	1462	29,8	98,0	2,6	7,8	0,6	1,8	3,4	90,6	91,4	90,9	0,80	0,05940	81	63
	Q2H160L4B	Aluminium	18,5	25,0	1470	36,0	120,2	2,3	6,8	0,7	2,2	2,9	91,2	92,0	91,6	0,81	0,09005	101	57
	Q2H160L4C	Aluminium	22,0	30,0	1462	41,8	143,8	1,8	5,5	0,6	1,9	2,8	91,6	92,9	93,3	0,84	0,11068	115	58
	Q2H180L4C	Aluminium	30,0	40,0	1475	55,3	194,6	2,7	8,2	0,9	2,7	3,5	92,0	91,9	91,4	0,85	0,14694	143	70
	Q2H200L4D	Aluminium	37,0	50,0	1476	72,5	240,8	2,8	8,3	0,9	2,8	3,7	92,7	93,2	92,8	0,79	0,26440	177	71
Q2EP250M4E	Cast Iron	75,0	100,0	1485	134,2	485,7	2,6	7,8	1,0	2,9	3,4	94,0	93,9	93,2	0,86	1,06110	610	72	
Q2EP280M4E	Cast Iron	110,0	150,0	1485	200,3	714,0	2,6	7,9	1,0	2,9	3,4	94,5	94,3	93,1	0,84	1,25200	688	73	

* IEC 60034-2-1'e göre / According to IEC 60034-2-1

** Ses Basınç Seviyeleri motordan 1m uzaklıktan ölçülmüştür. / The sound pressure measurements are taken 1m away from the motor

*** Tolerans +3 dBA / Tolerance +3 dBA

BOYUTLAR - B3 / DIMENSION - B3

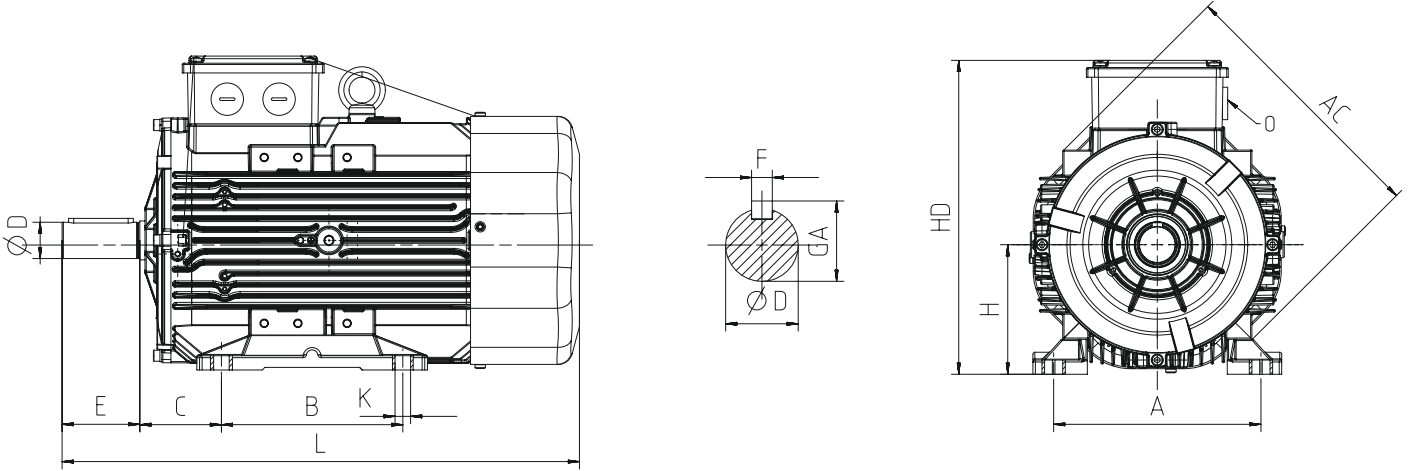

Güç Power (kW)	Kutup sayısı Number of Poles	Motor Tipi Motor Type	Gövde Tipi Housing Type	Ana Boyutlar Main Dimensions			Ayaklı Motorlar Foot Mounted Motors					Mil Shaft				Rulman Bearing		Keçe Seal		
				AC	L	O	B	A	H	HD	K	C	D ⁽¹⁾	E	GA	F ⁽²⁾	Kasnak Taraflı Drive Side	Kasnak Taraflı Aksı Non Drive Side	Kasnak Taraflı Drive Side	Kasnak Taraflı Aksı Non Drive Side
1,1	4	Q2H80M4D	Aluminium	158	268	1xM20	100	125	80	216	10	50	19	40	21,5	6	6204-ZZ	6204-ZZ	20*30*7	20*30*7
1,5	2	Q2H80M2D	Aluminium	158	268	1xM20	100	125	80	216	10	50	19	40	21,5	6	6204-ZZ	6204-ZZ	20*30*7	20*30*7
1,5	4	Q2H80M4DE	Aluminium	158	268	1xM20	100	125	80	216	10	50	19	40	21,5	6	6204-ZZ	6204-ZZ	20*30*7	20*30*7
2,2	2	Q2H80M2DE	Aluminium	158	268	1xM20	100	125	80	216	10	50	19	40	21,5	6	6204-ZZ	6204-ZZ	20*30*7	20*30*7
2,2	4	Q2H90L4D	Aluminium	172	344	1xM25	100-125	140	90	223	10	56	24	50	27,0	8	6305-ZZ	6205-ZZ	25*40*7	25*40*7
3,0	2	Q2H90L2D	Aluminium	172	344	1xM25	100-125	140	90	223	10	56	24	50	27,0	8	6305-ZZ	6205-ZZ	25*40*7	25*40*7
3,0	4	Q2H90L4DE	Aluminium	172	379	1xM25	100-125	140	90	223	10	56	24	50	27,0	8	6305-ZZ	6205-ZZ	25*40*7	25*40*7
4,0	2	Q2HS100L2C	Aluminium	172	384	1xM25	140	160	100	233	12	63	28	60	31,0	8	6306-ZZ	6205-ZZ	30*47*7	25*40*7
4,0	4	Q2H100L4D	Aluminium	191	400	1xM25	140	160	100	243	12	63	28	60	31,0	8	6306-ZZ	6205-ZZ	30*47*7	25*40*7
5,5	2	Q2HS112M2C	Aluminium	191	399	1xM25	140	190	112	254	12	70	28	60	31,0	8	6306-ZZ	6205-ZZ	30*47*7	25*40*7
5,5	4	Q2H112M4D	Aluminium	210	421	1xM25	140	190	112	265	12	70	28	60	31,0	8	6306-ZZ	6206-ZZ	30*47*7	30*47*7
7,5	2	Q2HS112M2D	Aluminium	191	421	1xM25	140	190	112	254	12	70	28	60	31,0	8	6306-ZZ	6205-ZZ	30*47*7	25*40*7
11,0	2	Q2H132M2A	Aluminium	260	481	1xM32	140-178	216	132	312	12	89	38	80	41,0	10	6208-ZZ	6208-ZZ	40*62*10	40*62*10
11,0	4	Q2H132M4D	Aluminium	260	481	1xM32	140-178	216	132	312	12	89	38	80	41,0	10	6208-ZZ	6208-ZZ	40*62*10	40*62*10
15,0	2	Q2H132M2B	Aluminium	260	481	1xM32	140-178	216	132	312	12	89	38	80	41,0	10	6208-ZZ	6208-ZZ	40*62*10	40*62*10
15,0	4	Q2H132M4E	Aluminium	260	539	1xM32	140-178	216	132	312	12	89	38	80	41,0	10	6208-ZZ	6208-ZZ	40*62*10	40*62*10
18,5	2	Q2H132M2C	Aluminium	260	539	1xM32	140-178	216	132	312	12	89	38	80	41,0	10	6208-ZZ	6208-ZZ	40*62*10	40*62*10
18,5	4	Q2H160L4B	Aluminium	305	591	1xM32	210-254	254	160	368	14,5	108	42	110	45,0	12	6309-ZZ	6209-ZZ	45*72*10	45*72*10
22,0	2	Q2H160L2C	Aluminium	305	591	1xM32	210-254	254	160	368	14,5	108	42	110	45,0	12	6309-ZZ	6209-ZZ	45*72*10	45*72*10
22,0	4	Q2H160L4C	Aluminium	305	591	1xM32	210-254	254	160	368	14,5	108	42	110	45,0	12	6309-ZZ	6209-ZZ	45*72*10	45*72*10
30,0	2	Q2H180M2B	Aluminium	349	696	1xM40	241-279	279	180	437	14,5	121	48	110	51,5	14	6310-ZZ	6310-ZZ	50*80*10	50*80*10
30,0	4	Q2H180L4C	Aluminium	349	696	1xM40	241-279	279	180	437	14,5	121	48	110	51,5	14	6310-ZZ	6310-ZZ	50*80*10	50*80*10
37,0	2	Q2H180M2C	Aluminium	349	696	1xM40	241-279	279	180	437	14,5	121	48	110	51,5	14	6310-ZZ	6310-ZZ	50*80*10	50*80*10
37,0	4	Q2H200L4D	Aluminium	349	759	1xM50	267-305	318	200	455	18,5	133	55	110	59,0	16	6312-ZZ	6310-ZZ	60*90*10	60*90*10
45,0	2	Q2H200L2D	Aluminium	349	759	1xM50	267-305	318	200	455	18,5	133	55	110	59,0	16	6312-ZZ	6310-ZZ	60*90*10	60*90*10
55,0	2	Q2E225M2C	Aluminium	456	735	1xM50	286-311	356	225	485	18,5	149	55	110	59,0	16	6313-ZZ	6313-ZZ	65*100*13	65*100*13
75,0	2	Q2EP250M2C	Cast Iron	489	893	1xM50	311-349	406	250	616	30	149	60	140	64,0	18	6316-Z	6316-Z	80*100*10	80*100*10
75,0	4	Q2EP250M4E	Cast Iron	489	893	1xM50	311-349	406	250	616	30	149	65	140	69,0	18	6316-Z	6316-Z	80*100*10	80*100*10
110,0	2	Q2EP280M2D	Cast Iron	489	1025	1xM50	368-419	457	280	647	24	190	65	140	69,0	18	6316-Z	6316-Z	80*100*10	80*100*10
110,0	4	Q2EP280M4E	Cast Iron	489	1025	1xM50	368-419	457	280	647	24	130	75	140	79,5	20	6316-Z	6316-Z	80*100*10	80*100*10

(1) Toleranslar 28 mm'ye kadar DIN EN 50347 "j6", 28 mm ve üzeri "k6" / Tolerance DIN EN 50347 "j6" up to 28mm, "k6" above 28mm
(2) DIN 6885'e göre / According to DIN 6885

BOYUTLAR - B5, B35 / DIMENSION - B5, B35

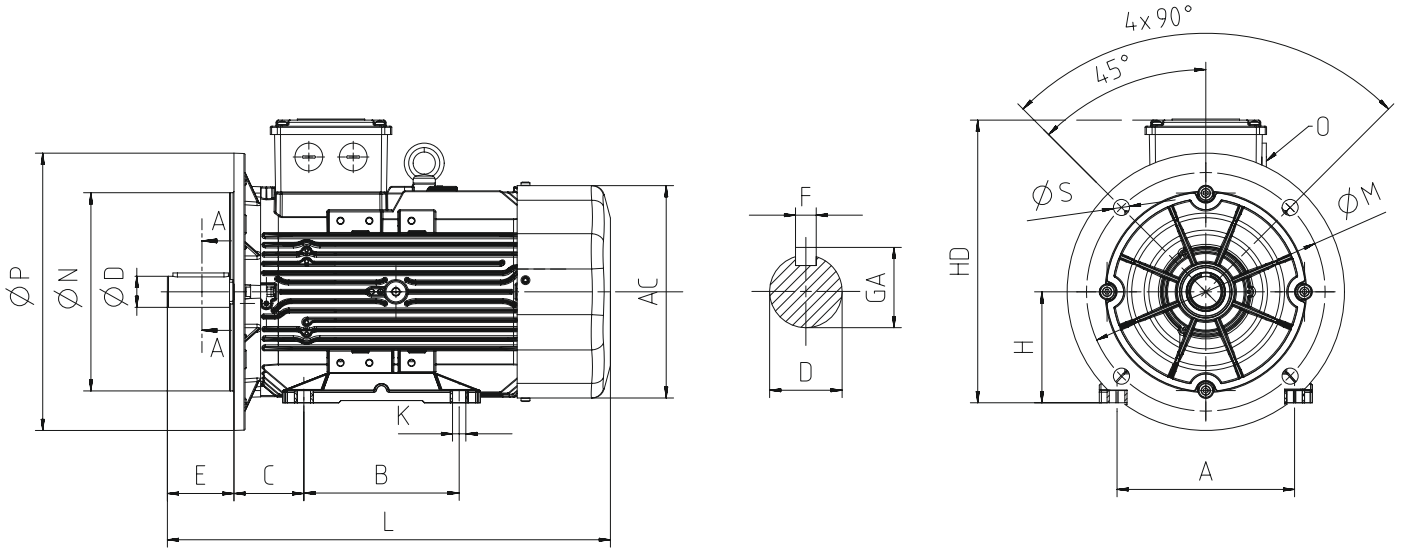

Güç Power (kW)	Kutup sayısı Number of Poles	Motor Tipi Motor Type	Gövde Tipi Housing Type	Ana Boyutlar Main Dimensions			Ayaklı Motorlar Foot Mounted Motors					Mil Shaft		Rulman Bearing		Keçe Seal		Flanş (FA) (B5) Flange (FA) (B5)						
				AC	L	O	B	A	H	HD	K	D ⁽¹⁾	E	GA	F ⁽²⁾	Kasnak Taraflı Drive Side	Kasnak Taraflı Aksı Non drive Side	Kasnak Taraflı Drive Side	Kasnak Taraflı Aksı Non drive Side	P	N ⁽³⁾	M	R	S
1,1	4	Q2H80M4D	Aluminium	158	268	1xM20	100	125	80	216	10,0	19	40	21,5	6	6204-ZZ	6204-ZZ	20*30*7	20*30*7	200	130	165	-	12,0
1,5	2	Q2H80M2D	Aluminium	158	268	1xM20	100	125	80	216	10,0	19	40	21,5	6	6204-ZZ	6204-ZZ	20*30*7	20*30*7	200	130	165	-	12,0
1,5	4	Q2H80M4DE	Aluminium	158	268	1xM20	100	125	80	216	10,0	19	40	21,5	6	6204-ZZ	6204-ZZ	20*30*7	20*30*7	200	130	165	-	12,0
2,2	2	Q2H80M2DE	Aluminium	158	268	1xM20	100	125	80	216	10,0	19	40	21,5	6	6204-ZZ	6204-ZZ	20*30*7	20*30*7	200	130	165	-	12,0
2,2	4	Q2H90L4D	Aluminium	172	344	1xM25	100-125	140	90	223	10,0	24	50	27,0	8	6305-ZZ	6205-ZZ	25*40*7	25*40*7	200	130	165	-	12,0
3,0	2	Q2H90L2D	Aluminium	172	344	1xM25	100-125	140	90	223	10,0	24	50	27,0	8	6305-ZZ	6205-ZZ	25*40*7	25*40*7	200	130	165	-	12,0
3,0	4	Q2H90L4DE	Aluminium	172	379	1xM25	100-125	140	90	223	10,0	24	50	27,0	8	6305-ZZ	6205-ZZ	25*40*7	25*40*7	200	130	165	-	12,0
4,0	2	Q2HS100L2C	Aluminium	172	384	1xM25	140	160	100	233	12,0	28	60	31,0	8	6306-ZZ	6205-ZZ	30*47*7	25*40*7	250	180	215	-	14,5
4,0	4	Q2H100L4D	Aluminium	191	400	1xM25	140	160	100	243	12,0	28	60	31,0	8	6306-ZZ	6205-ZZ	30*47*7	30*47*7	250	180	215	-	14,5
5,5	2	Q2HS112M2C	Aluminium	191	399	1xM25	140	190	112	254	12,0	28	60	31,0	8	6306-ZZ	6205-ZZ	30*47*7	25*40*7	250	180	215	-	14,5
5,5	4	Q2H112M4D	Aluminium	210	421	1xM25	140	190	112	265	12,0	28	60	31,0	8	6306-ZZ	6206-ZZ	30*47*7	30*47*7	250	180	215	-	14,5
7,5	2	Q2HS112M2D	Aluminium	191	421	1xM25	140	190	112	254	12,0	28	60	31,0	8	6306-ZZ	6205-ZZ	30*47*7	25*40*7	250	180	215	-	14,5
11,0	2	Q2H132M2A	Aluminium	260	481	1xM32	140-178	216	132	312	12,0	38	80	41,0	10	6208-ZZ	6208-ZZ	40*62*10	40*62*10	300	230	265	-	14,5
11,0	4	Q2H132M4D	Aluminium	260	481	1xM32	140-178	216	132	312	12,0	38	80	41,0	10	6208-ZZ	6208-ZZ	40*62*10	40*62*10	300	230	265	-	14,5
15,0	2	Q2H132M2B	Aluminium	260	481	1xM32	140-178	216	132	312	12,0	38	80	41,0	10	6208-ZZ	6208-ZZ	40*62*10	40*62*10	300	230	265	-	14,5
15,0	4	Q2H132M4E	Aluminium	260	539	1xM32	140-178	216	132	312	12,0	38	80	41,0	10	6208-ZZ	6208-ZZ	40*62*10	40*62*10	300	230	265	-	14,5
18,5	2	Q2H132M2C	Aluminium	260	539	1xM32	140-178	216	132	312	12,0	38	80	41,0	10	6208-ZZ	6208-ZZ	40*62*10	40*62*10	300	230	265	-	14,5
18,5	4	Q2H160L4B	Aluminium	305	591	1xM32	210-254	254	160	368	14,5	42	110	45,0	12	6309-ZZ	6209-ZZ	45*72*10	45*72*10	350	250	300	-	18,5
22,0	2	Q2H160L2C	Aluminium	305	591	1xM32	210-254	254	160	368	14,5	42	110	45,0	12	6309-ZZ	6209-ZZ	45*72*10	45*72*10	350	250	300	-	18,5
22,0	4	Q2H160L4C	Aluminium	305	591	1xM32	210-254	254	160	368	14,5	42	110	45,0	12	6309-ZZ	6209-ZZ	45*72*10	45*72*10	350	250	300	-	18,5
30,0	2	Q2H180M2B	Aluminium	349	696	1xM40	241-279	279	180	437	14,5	48	110	51,5	14	6310-ZZ	6310-ZZ	50*80*10	50*80*10	350	250	300	-	18,5
30,0	4	Q2H180L4C	Aluminium	349	696	1xM40	241-279	279	180	437	14,5	48	110	51,5	14	6310-ZZ	6310-ZZ	50*80*10	50*80*10	350	250	300	-	18,5
37,0	2	Q2H180M2C	Aluminium	349	696	1xM40	241-279	279	180	437	14,5	48	110	51,5	14	6310-ZZ	6310-ZZ	50*80*10	50*80*10	350	250	300	-	18,5
37,0	4	Q2H200L4D	Aluminium	349	759	1xM50	267-305	318	200	455	18,5	55	110	59,0	16	6312-ZZ	6310-ZZ	60*90*10	60*90*10	400	300	350	-	18,5
45,0	2	Q2H200L2D	Aluminium	349	759	1xM50	267-305	318	200	455	18,5	55	110	59,0	16	6312-ZZ	6310-ZZ	60*90*10	60*90*10	400	300	350	-	18,5
55,0	2	Q2E225M2C	Aluminium	456	735	1xM50	286-311	356	225	485	18,5	55	110	59,0	16	6313-ZZ	6313-ZZ	65*100*13	65*100*13	450	350	400	-	18,5
75,0	2	Q2EP250M2C	Cast Iron	489	893	1xM50	349	406	250	616	24,0	60	140	69,0	18	6316-Z	6316-Z	80*100*10	80*100*10	550	450	500	-	18,5
75,0	4	Q2EP250M4E	Cast Iron	489	893	1xM50	349	406	250	616	24,0	65	140	69,0	18	6316-Z	6316-Z	80*100*10	80*100*10	550	450	500	-	18,5
110,0	2	Q2EP280M2D	Cast Iron	489	1025	1xM50	419	457	280	647	24,0	65	140	69,0	18	6316-Z	6316-Z	80*100*10	80*100*10	550	450	500	-	18,5
110,0	4	Q2EP280M4E	Cast Iron	489	1025	1xM50	419	457	280	647	24,0	75	140	79,5	20	6316-Z	6316-Z	80*100*10	80*100*10	550	450	500	-	18,5

(1) Toleranslar 28 mm'ye kadar DIN EN 50347 "j6", 28 mm ve üzeri "k6" / Tolerance DIN EN 50347 "j6" up to 28mm, "k6" above 28mm

(2) DIN 6885'e göre / According to DIN 6885

(3) Tolerans DIN EN 50347 "j6" / Tolerance DIN EN 50347 "j6"

BOYUTLAR - B14a, B34a / DIMENSION - B14a, B34a

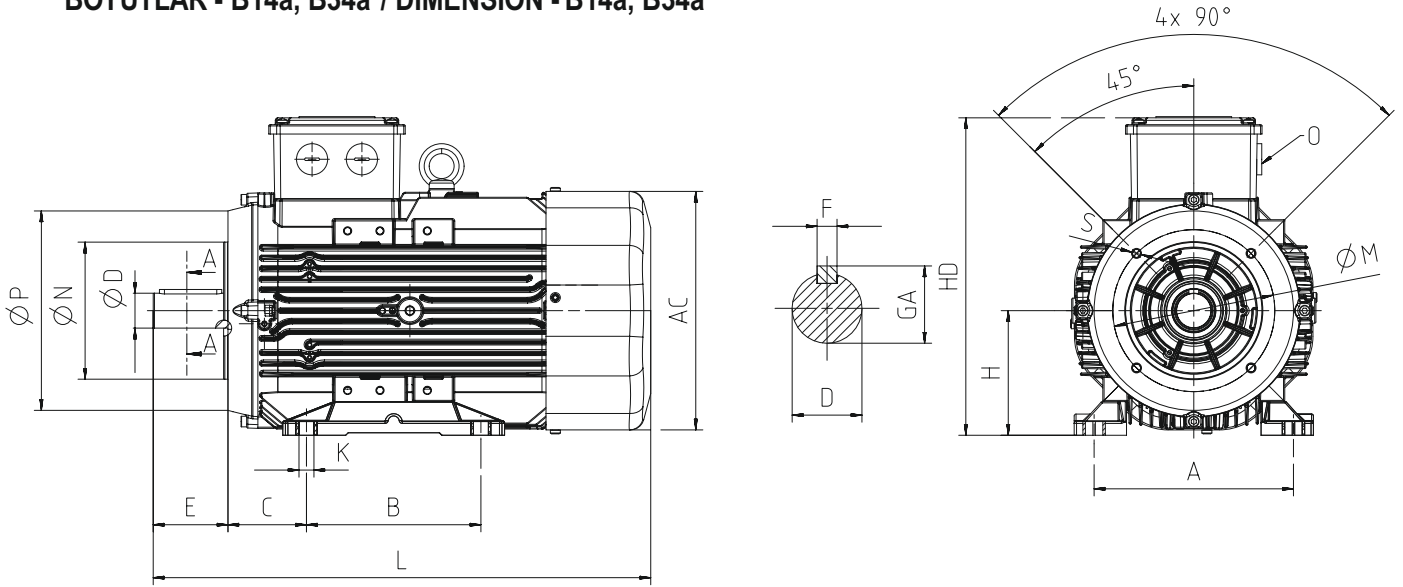

Güç Power (kW)	Kutup sayısı Number of Poles	Motor Tipi Motor Type	Gövde Tipi Housing Type	Ana Boyutlar Main Dimensions			Ayaklı Motorlar Foot Mounted Motors					Mil Shaft			Rulman Bearing		Keçe Seal		Flanş (FC) (B14a) Flange (FC) (B14a)					
				AC	L	O	B	A	H	HD	K	D ⁽¹⁾	E	GA	F ⁽²⁾	Kasnak Tarafı Drive Side	Kasnak Tarafı Aksı Non drive Side	Kasnak Tarafı Drive Side	Kasnak Tarafı Aksı Non drive Side	P	N ⁽³⁾	M	R	S
1,1	4	Q2H80M4D	Aluminium	158	268	1xM20	100	125	80	216	10	19	40	21,5	6	6204-ZZ	6204-ZZ	20*30*7	20*30*7	120	80	100	-	M6
1,5	2	Q2H80M2D	Aluminium	158	268	1xM20	100	125	80	216	10	19	40	21,5	6	6204-ZZ	6204-ZZ	20*30*7	20*30*7	120	80	100	-	M6
1,5	4	Q2H80M4DE	Aluminium	158	268	1xM20	100	125	80	216	10	19	40	21,5	6	6204-ZZ	6204-ZZ	20*30*7	20*30*7	120	80	100	-	M6
2,2	2	Q2H80M2DE	Aluminium	158	268	1xM20	100	125	80	216	10	19	40	21,5	6	6204-ZZ	6204-ZZ	20*30*7	20*30*7	120	80	100	-	M6
2,2	4	Q2H90L4D	Aluminium	172	344	1xM25	100-125	140	90	223	10	24	50	27,0	8	6305-ZZ	6205-ZZ	25*40*7	25*40*7	140	95	115	-	M8
3,0	2	Q2H90L2D	Aluminium	172	344	1xM25	100-125	140	90	223	10	24	50	27,0	8	6305-ZZ	6205-ZZ	25*40*7	25*40*7	140	95	115	-	M8
3,0	4	Q2H90L4DE	Aluminium	172	379	1xM25	100-125	140	90	223	10	24	50	27,0	8	6305-ZZ	6205-ZZ	25*40*7	25*40*7	140	95	115	-	M8
4,0	2	Q2HS100L2C	Aluminium	172	384	1xM25	140	160	100	233	12	28	60	31,0	8	6306-ZZ	6205-ZZ	30*47*7	25*40*7	160	110	130	-	M8
4,0	4	Q2H100L4D	Aluminium	191	400	1xM25	140	160	100	243	12	28	60	31,0	8	6306-ZZ	6205-ZZ	30*47*7	30*47*7	160	110	130	-	M8
5,5	2	Q2HS112M2C	Aluminium	191	399	1xM25	140	190	112	254	12	28	60	31,0	8	6306-ZZ	6205-ZZ	30*47*7	25*40*7	160	110	130	-	M8
5,5	4	Q2H112M4D	Aluminium	210	421	1xM25	140	190	112	265	12	28	60	31,0	8	6306-ZZ	6206-ZZ	30*47*7	30*47*7	160	110	130	-	M8
7,5	2	Q2HS112M2D	Aluminium	191	421	1xM25	140	190	112	254	12	28	60	31,0	8	6306-ZZ	6205-ZZ	30*47*7	25*40*7	160	110	130	-	M8
11,0	2	Q2H132M2A	Aluminium	260	481	1xM32	140-178	216	132	312	12	38	80	41,0	10	6208-ZZ	6208-ZZ	40*62*10	40*62*10	200	130	165	-	M10
11,0	4	Q2H132M4D	Aluminium	260	539	1xM32	140-178	216	132	312	12	38	80	41,0	10	6208-ZZ	6208-ZZ	40*62*10	40*62*10	200	130	165	-	M10
15,0	2	Q2H132M2B	Aluminium	260	539	1xM32	140-178	216	132	312	12	38	80	41,0	10	6208-ZZ	6208-ZZ	40*62*10	40*62*10	200	130	165	-	M10
15,0	4	Q2H132M4E	Aluminium	260	539	1xM32	140-178	216	132	312	12	38	80	41,0	10	6208-ZZ	6208-ZZ	40*62*10	40*62*10	200	130	165	-	M10
18,5	2	Q2H132M2C	Aluminium	260	539	1xM32	140-178	216	132	312	12	38	80	41,0	10	6208-ZZ	6208-ZZ	40*62*10	40*62*10	200	130	165	-	M10

(1) Toleranslar 28 mm'ye kadar DIN EN 50347 "j6", 28 mm ve üzeri "k6" / Tolerance DIN EN 50347 "j6" up to 28mm, "k6" above 28mm

(2) DIN 6885'e göre / According to DIN 6885

(3) Tolerans DIN EN 50347 "j6" / Tolerance DIN EN 50347 "j6"

BOYUTLAR - B14b, B34b / DIMENSION - B14b, B34b

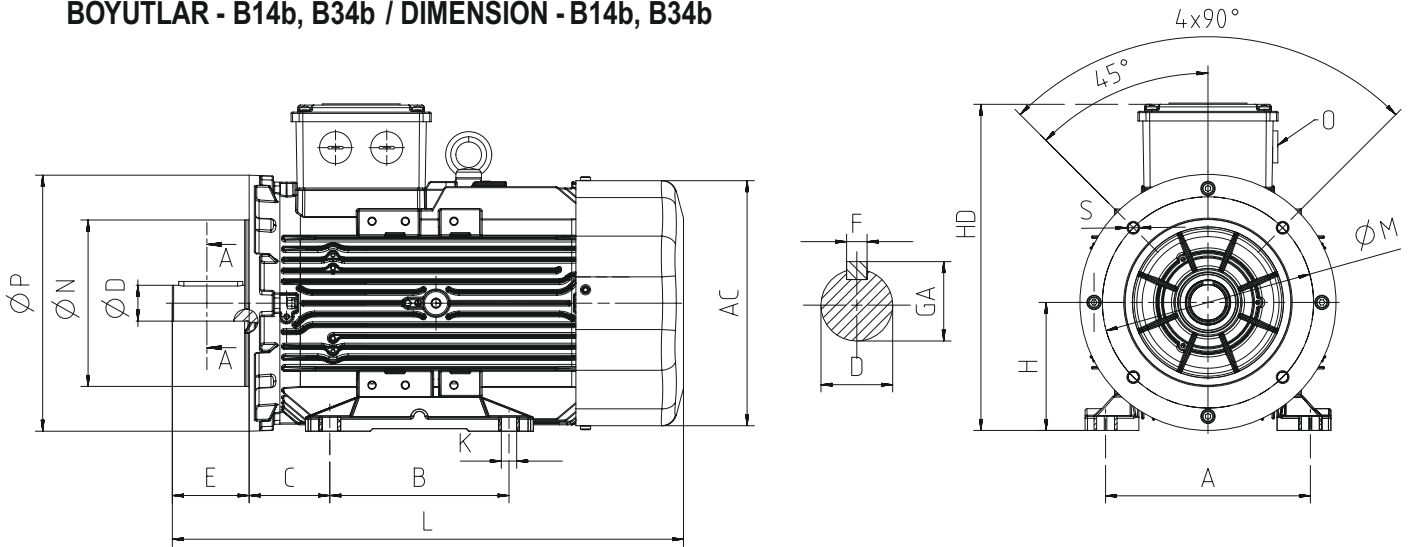

Güç Power (kW)	Kutup sayısı Number of Poles	Motor Tipi Motor Type	Gövde Tipi Housing Type	Ana Boyutlar Main Dimensions			Ayaklı Motorlar Foot Mounted Motors					Mil Shaft			Rulman Bearing		Keçe Seal		Flanş (FB) (B14b) Flange (FB) (B14b)					
				AC	L	O	B	A	H	HD	K	D ⁽¹⁾	E	GA	F ⁽²⁾	Kasnak Tarafı Drive Side	Kasnak Tarafı Aksı Non drive Side	Kasnak Tarafı Drive Side	Kasnak Tarafı Aksı Non drive Side	P	N ⁽³⁾	M	R	S
1,1	4	Q2H80M4D	Aluminium	158	268	1xM20	100	125	80	216	10	19	40	21,5	6	6204-ZZ	6204-ZZ	20*30*7	20*30*7	160	110	130	-	M8
1,5	2	Q2H80M2D	Aluminium	158	268	1xM20	100	125	80	216	10	19	40	21,5	6	6204-ZZ	6204-ZZ	20*30*7	20*30*7	160	110	130	-	M8
1,5	4	Q2H80M4DE	Aluminium	158	268	1xM20	100	125	80	216	10	19	40	21,5	6	6204-ZZ	6204-ZZ	20*30*7	20*30*7	160	110	130	-	M8
2,2	2	Q2H80M2DE	Aluminium	158	268	1xM20	100	125	80	216	10	19	40	21,5	6	6204-ZZ	6204-ZZ	20*30*7	20*30*7	160	110	130	-	M8
2,2	4	Q2H90L4D	Aluminium	172	344	1xM25	100-125	140	90	223	10	24	50	27,0	8	6305-ZZ	6205-ZZ	25*40*7	25*40*7	160	110	130	-	M8
3,0	2	Q2H90L2D	Aluminium	172	344	1xM25	100-125	140	90	223	10	24	50	27,0	8	6305-ZZ	6205-ZZ	25*40*7	25*40*7	160	110	130	-	M8
3,0	4	Q2H90L4DE	Aluminium	172	379	1xM25	100-125	140	90	223	10	24	50	27,0	8	6305-ZZ	6205-ZZ	25*40*7	25*40*7	160	110	130	-	M8
4,0	2	Q2HS100L2C	Aluminium	172	384	1xM25	140	160	100	233	12	28	60	31,0	8	6306-ZZ	6205-ZZ	30*47*7	25*40*7	200	130	165	-	M10
4,0	4	Q2H100L4D	Aluminium	191	400	1xM25	140	160	100	243	12	28	60	31,0	8	6306-ZZ	6205-ZZ	30*47*7	30*47*7	200	130	165	-	M10
5,5	2	Q2HS112M2C	Aluminium	191	399	1xM25	140	190	112	254	12	28	60	31,0	8	6306-ZZ	6205-ZZ	30*47*7	25*40*7	200	130	165	-	M10
5,5	4	Q2H112M4D	Aluminium	210	421	1xM25	140	190	112	265	12	28	60	31,0	8	6306-ZZ	6206-ZZ	30*47*7	30*47*7	200	130	165	-	M10
7,5	2	Q2HS112M2D	Aluminium	191	421	1xM25	140	190	112	254	12	28	60	31,0	8	6306-ZZ	6205-ZZ	30*47*7	25*40*7	200	130	165	-	M10
11,0	2	Q2H132M2A	Aluminium	260	481	1xM32	140-178	216	132	312	12	38	80	41,0	10	6208-ZZ	6208-ZZ	40*62*10	40*62*10	250	180	215	-	M12
11,0	4	Q2H132M4D	Aluminium	260	539	1xM32	140-178	216	132	312	12	38	80	41,0	10	6208-ZZ	6208-ZZ	40*62*10	40*62*10	250	180	215	-	M12
15,0	2	Q2H132M2B	Aluminium	260	539	1xM32	140-178	216	132	312	12	38	80	41,0	10	6208-ZZ	6208-ZZ	40*62*10	40*62*10	250	180	215	-	M12
15,0	4	Q2H132M4E	Aluminium	260	539	1xM32	140-178	216	132	312	12	38	80	41,0	10	6208-ZZ	6208-ZZ	40*62*10	40*62*10	250	180	215	-	M12
18,5	2	Q2H132M2C	Aluminium	260	539	1xM32	140-178	216	132	312	12	38	80	41,0	10	6208-ZZ	6208-ZZ	40*62*10	40*62*10	250	180	215	-	M12

(1) Toleranslar 28 mm'ye kadar DIN EN 50347 "j6", 28 mm ve üzeri "k6" / Tolerance DIN EN 50347 "j6" up to 28mm, "k6" above 28mm

(2) DIN 6885'e göre / According to DIN 6885

(3) Tolerans DIN EN 50347 "j6" / Tolerance DIN EN 50347 "j6"

TR MOTOR PARÇA LİSTESİ

EN MOTOR PART LIST

DE ERSATZTEILLISTE FÜR MOTOR

IT ELENCO PARTI MOTORE

FR LISTE DES PIÈCES DU MOTEUR

ES LISTA DE PIEZAS DEL MOTOR

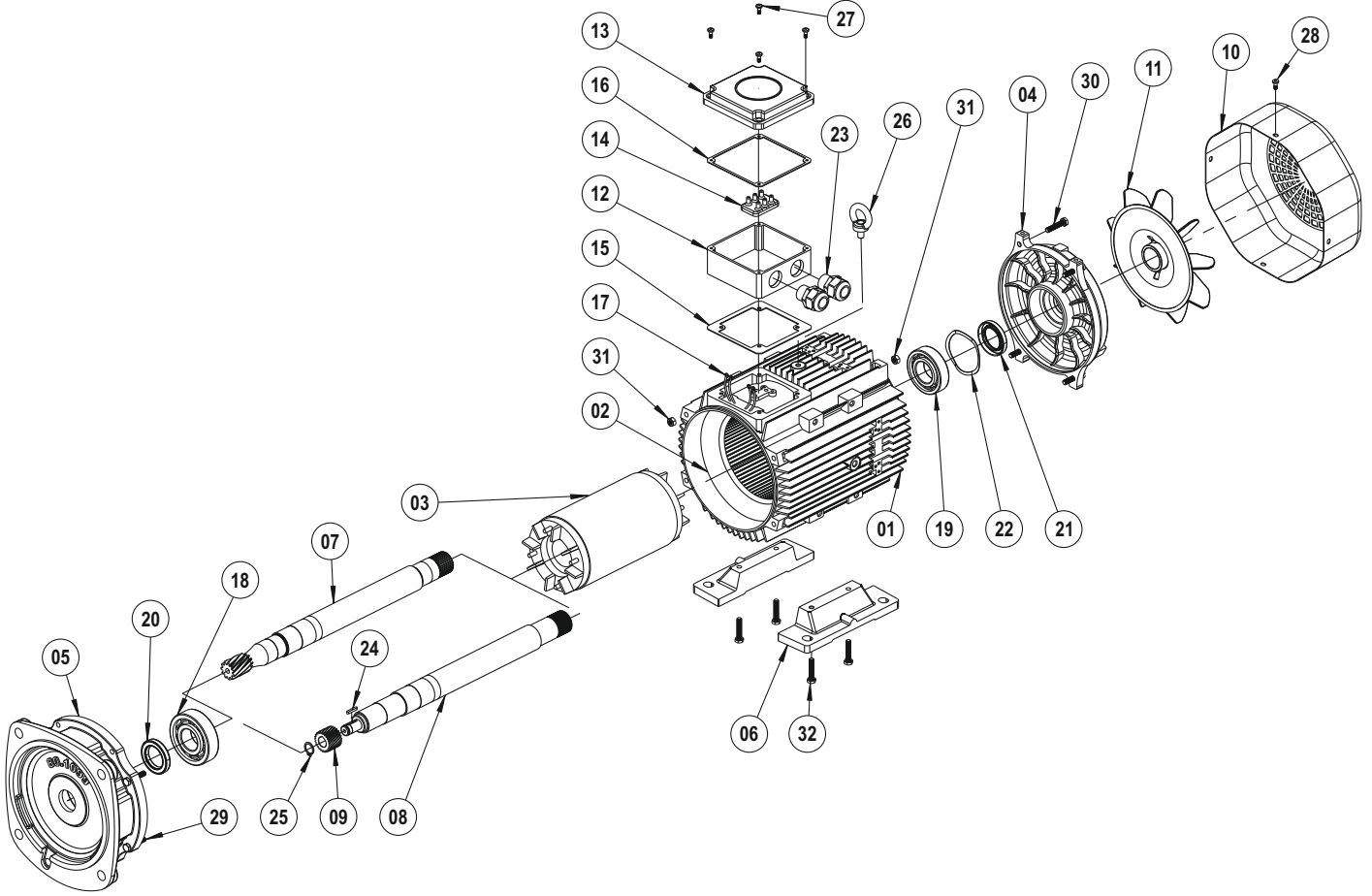

01	Gövde	Housing	Gehäuse	Involucro	corps	cuerpo
02	Sargılı Stator	Wound Stator	gewickelter Stator	Statore	Stator	Stator
03	Rotor	Rotor	Rotor	Rotore	Rotor	Rotor
04	Motor Arka Kapağı	Nondrive - Endshield	B-Lagerschild	Portellone motore	Portellone motore	Tapa trasera del motor
05	Motor Bağlantı Flaşı	Motor Connection Flange	Moter-Anschlussflansch	Flangia di collegamento del motore	Bride de raccordement moteur	Brida de conexión del motor
06	Ayak	Foot	Fuß	Piede	Pied	Pie
07	Motor Mili (Yekpare)	Drive Shaft (Gearcut)	Antriebswelle (verzahnt)	Albero motore (monolithic)	Arbre moteur (monolithique)	eje motor (monolítico)
08	Motor Mili (Çakma)	Drive Shaft (Plain)	Antriebswelle (glatt)	Albero motore (dritto)	Arbre moteur (lisse)	eje motor (suave)
09	Z1 Dişlisi	Z1 Gear	Antriebsritzel	Ingresso Pignone	Pignon d'entrée	Piñón de entrada
10	Fan Kapağı	Fan Cover	Lüfterhaube	Copriventola	Couvercle	versión de fan
11	Fan	Fan	Lüfter	Fan	Fan	Fan
12	Terminal Kutusu	Terminal Box	Klemmkasten	Morsettiara	Boîte à bornes	Caja de terminales
13	Terminal Kutu Kapağı	Terminal Box Cover	Klemmkastendeckel	Coperchio della morsettiara	Couvercle de la boîte à bornes	Cubierta de la caja de terminales
14	Klemens Plakası	Terminal Plate	Anschlussplatte	Piastra terminale	Plaque à bornes	Placa de terminales
15	Terminal Contası Alt	Terminal Gasket Down	Klemmkastendichtung unten	Sigillo terminale - giù	Joint de borne - bas	Junta de terminal - inferior
16	Terminal Contası Üst	Terminal Gasket Up	Klemmkastendichtung oben	Sigillo terminale - su	Joint de borne - haut	Junta de terminal - superior
17	Kablo Grubu	Lead Cables	Kabelbaum	Cavi di piombo	Câbles de plomb	Cables de plomo
18	Ön Rulman	Bal Bearing (Drive-Side)	Kugellager (Antriebsseite)	Cuscinetto (fronte)	Roulement (avant)	Cojinete (delantero)
19	Arka Rulman	Bal Bearing (Non-Drive-Side)	Kugellager (Nicht-Antriebsseite)	Cuscinetto (retro)	Roulement (arrière)	Cojinete (trasero)
20	Keçe (Ön)	Seal Ring (Front)	Dichtungsring (Vorne)	Anello di tenuta (anteriore)	Bague d'étanchéité (avant)	Anillo de sellado (delantero)
21	Keçe (Arka)	Seal Ring (Back)	Dichtungsring (Hinten)	anello di tenuta (posteriore)	Bague d'étanchéité (arrière)	Anillo de sellado (trasero)
22	Rulman Gergi Yayı	Bearing Shim	Stützscheibe	molla del cuscinetto	ressort de roulement	resorte rodante
23	Rakor	Conduit	Gewindemuffe	presa filettata	douille fileté	casquillo roscado
24	Kama	Key	Passfeder	Chiavetta	Clavette	Clave
25	Segman	Circlip DIN 471	Sicherungsring DIN 471	Anello di sicurezza DIN 471	Circlip DIN 471	Anillo de seguridad DIN 471
26	Mapa	Eye Bolt	Augenschraube	vite ad anello	anneau de levage	Perno de anilla
27	Yıldız Başlı Civata	Pan Head Screws	Kreuzschlitzschraube	Viti a Stella	Vis étoile	tornillo de estrella
28	Yıldız Başlı Civata	Pan Head Screws	Kreuzschlitzschraube	Viti a Stella	Vis étoile	tornillo de estrella
29	Civata DIN 933	Bolt	Schraube DIN 933	Bullone	Boulonner	Atornillar
30	Civata DIN 933	Bolt	Schraube DIN 933	Bullone	Boulonner	Atornillar
31	Somun	Nut	Schraubenmutter	Dado	Ecrou	Tuerca
32	Civata DIN 933	Bolt	Schraube DIN 933	Bullone	Boulonner	Atornillar

TR FRENLİ MOTOR PARÇA LİSTESİ
IT ELENCO DELLE PARTI DEL MOTORE DEL FRENO

EN BRAKE MOTOR PART LIST
FR LISTE DES PIÈCES DU MOTEUR DE FREIN

DE ERSATZTEILLISTE FÜR MOTOR MIT BREMSE
ES LISTA DE PIEZAS DEL MOTOR DE FRENO

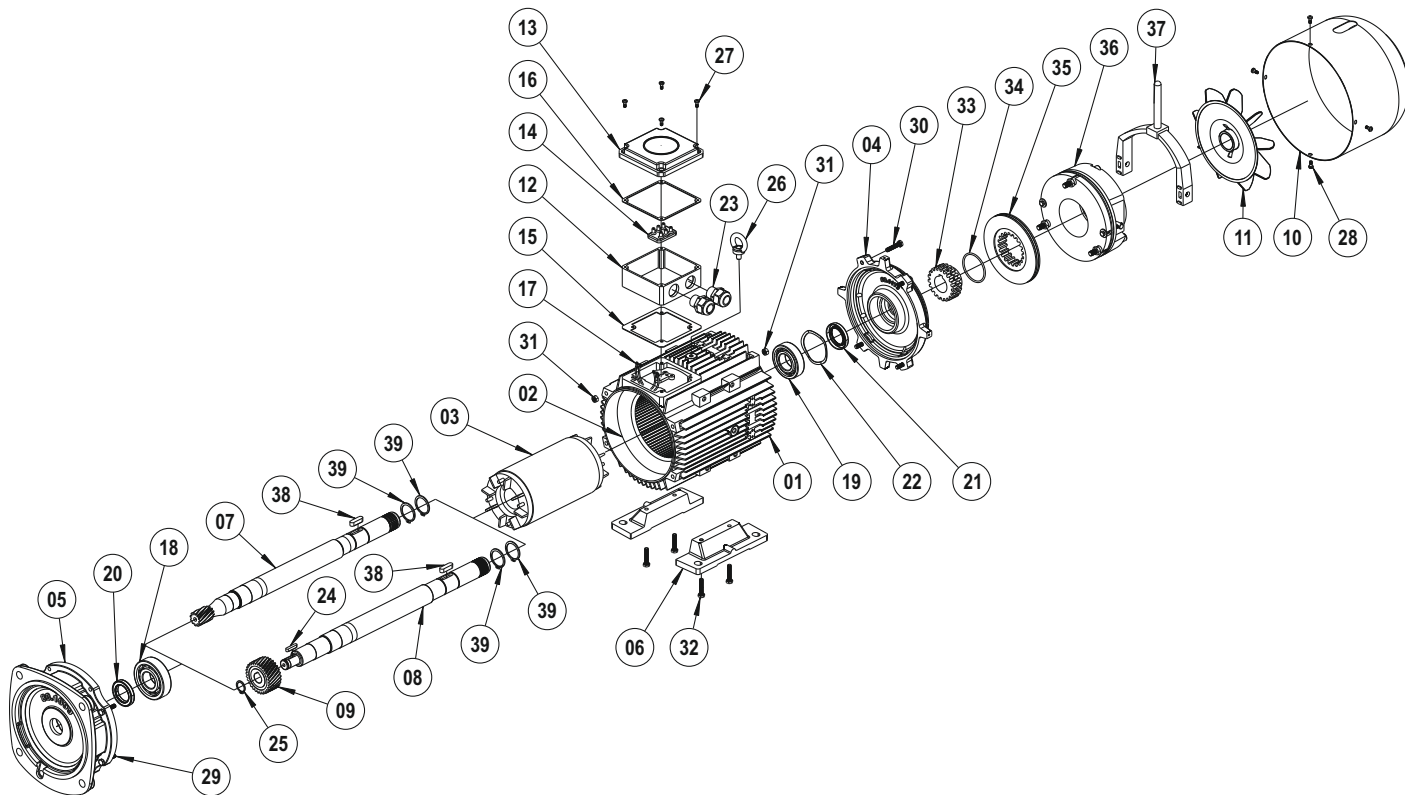

01	Gövde	Housing	Gehäuse	Involucro	corps	cuerpo
02	Sargılı Stator	Wound Stator	gewickelter Stator	Statore	Stator	Stator
03	Rotor	Rotor	Rotor	Rotore	Rotor	Rotor
04	Fren Flanşı	Brake Connection Flange	Bremsflansch	Flangia di collegamento del freno	Bride de connexion de frein	Brida de conexión de freno
05	Motor Bağlantı Flanşı	Motor Connection Flange	Moter-Anschlussflansch	Flangia di collegamento del motore	Bride de raccordement moteur	Brida de conexión del motor
06	Ayak	Foot	Fuß	Piede	Pied	Pie
07	Motor Mili (Yekpare)	Drive Shaft (Gearcut)	Antriebswelle (verzahnt)	Albero motore (monolithic)	Arbre moteur (monolithique)	eje motor (monolítico)
08	Motor Mili (Çakma)	Drive Shaft (Plain)	Antriebswelle (glatt)	Albero motore (dritto)	Arbre moteur (lisse)	eje motor (suave)
09	Z1 Dişlisi	Z1 Gear	Antriebsritzel	Ingresso Pignone	Pignon d'entrée	Piñón de entrada
10	Fan Kapağı	Fan Cover	Lüfterhaube	Copriventola	Couvercle	versión de fan
11	Fan	Fan	Lüfter	Fan	Fan	Fan
12	Terminal Kutusu	Terminal Box	Klemmkasten	Morsettiara	Boîte à bornes	Caja de terminales
13	Terminal Kutu Kapağı	Terminal Box Cover	Klemmkastendeckel	Coperchio della morsettiara	Couvercle de la boîte à bornes	Cubierta de la caja de terminales
14	Klemens Plakası	Terminal Plate	Anschlussplatte	Plastra terminale	Plaque à bornes	Placa de terminales
15	Terminal Contası Alt	Terminal Gasket Down	Klemmkastendichtung unten	Sigillo terminale - giù	Joint de borne - bas	Junta de terminal - inferior
16	Terminal Contası Üst	Terminal Gasket Up	Klemmkastendichtung oben	Sigillo terminale - su	Joint de borne - haut	Junta de terminal - superior
17	Kablo Grubu	Lead Cables	Kabelbaum	Cavi di piombo	Câbles de plomb	Cables de plomo
18	Ön Rulman	Bal Bearing (Drive-Side)	Kugellager (Antriebsseite)	Cuscinetto (fronte)	Roulement (avant)	Cojinete (delantero)
19	Arka Rulman	Bal Bearing (Non-Drive-Side)	Kugellager (Nicht-Antriebsseite)	Cuscinetto (retro)	Roulement (arrière)	Cojinete (trasero)
20	Keçe (Ön)	Seal Ring (Front)	Dichtungsring (Vorne)	Anello di tenuta (anteriore)	Bague d'étanchéité (avant)	Anillo de sellado (delantero)
21	Keçe (Arka)	Seal Ring (Back)	Dichtungsring (Hinten)	anello di tenuta (posteriore)	Bague d'étanchéité (arrière)	Anillo de sellado (trasero)
22	Rulman Gergi Yayı	Bearing Shim	Stützscheibe	molla del cuscinetto	ressort de roulement	resorte rodante
23	Rakor	Conduit	Gewindemuffe	presa filettata	douille fileté	casquillo roscado
24	Kama	Key	Passfeder	Chiavetta	Clavette	Clave
25	Segman	Circlip DIN 471	Sicherungsring DIN 471	Anello di sicurezza DIN 471	Circlip DIN 471	Anillo de seguridad DIN 471
26	Mapa	Eye Bolt	Augenschraube	vite ad anello	anneau de levage	Perno de anilla
27	Yıldız Başlı Civata	Pan Head Screws	Kreuzschlitzschraube	Viti a Stella	Vis étoile	tornero de estrella
28	Yıldız Başlı Civata	Pan Head Screws	Kreuzschlitzschraube	Viti a Stella	Vis étoile	tornero de estrella
29	Civata DIN 933	Bolt	Schraube DIN 933	Bullone	Boulonner	Atornillar
30	Civata DIN 933	Bolt	Schraube DIN 933	Bullone	Boulonner	Atornillar
31	Somun	Nut	Schraubenmutter	Dado	Ecrou	Tuerca
32	Civata DIN 933	Bolt	Schraube DIN 933	Bullone	Boulonner	Atornillar
33	Fren Kaplini	Coupling	Kupplung	Accoppiamento	Couplage	Acoplamiento
34	O-Ring	O-Ring	O-Ring	O-Ring	O-Ring	O-Ring
35	Fren Balatası	Brake Lining	Bremsbelag	Guarnizioni dei freni	Garniture de frein	Romper el forro
36	Fren	Brake	Bremse	freno	Frein	Freno
37	Manuel Kolu	Hand Release	Handauslöser	Leva manuale	Levier manuel	Palanca manual
38	Kama	Key	Passfeder	Chiavetta	Clavette	Clave
39	Segman DIN 471	Circlip DIN 471	Sicherungsring DIN 471	Anello di sicurezza DIN 471	Circlip DIN 471	Anillo de seguridad DIN 471

TR B3-B5-B14 FLANŞLI MOTOR
PARÇA LİSTESİ

EN B3-B5-B14 FLANGE MOTOR PART LIST

DE ERSATZTEILLISTE FÜR MOTOR
MIT B3-B5-B14-FLANSCH

IT B3-B5-B14 ELENCO PARTI
MOTORE FLANGIA

FR LISTE DES PIÈCES DU MOTEUR
À BRIDE B3-B5-B14

ES B3-B5-B14 LISTA DE PIEZAS DEL
MOTOR CON BRIDA

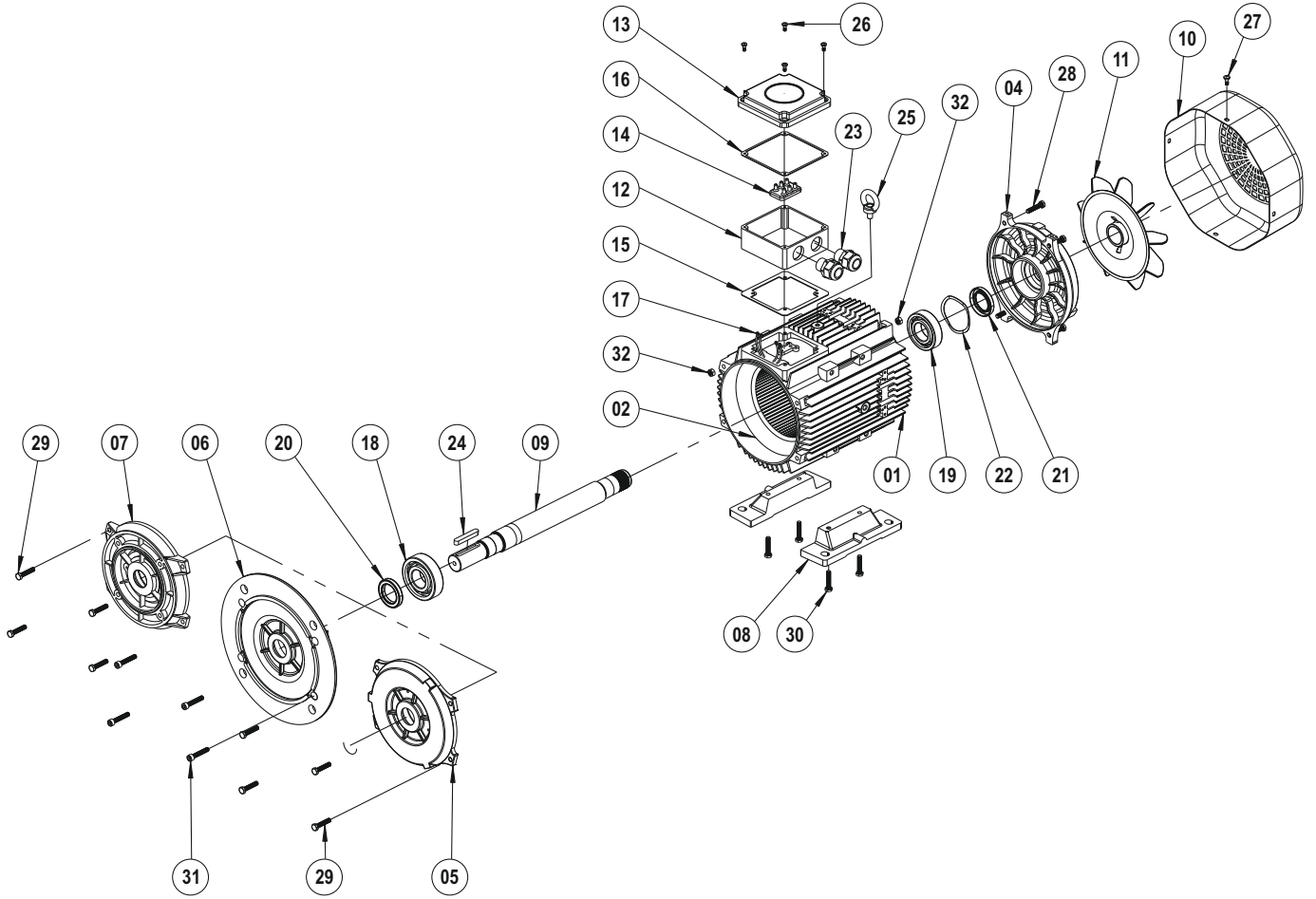

01	Gövde	Housing	Gehäuse	Involucro	corps	cuerpo
02	Sargılı Stator	Wound Stator	gewickelter Stator	Statore	Stator	Stator
03	Rotor	Rotor	Rotore	Rotore	Rotor	Rotor
04	Motor Arka Kapağı	Nondrive - Endshield	B-Lagerschild	Portellone motore	Portellone motore	Tapa trasera del motor
05	B3 Motor Bağlantı Flanşı	B3 Flange	B3 Flansch	Flangia B3	Bride B3	Brida B3
06	B5 Motor Bağlantı Flanşı	B5 Flange	B5 Flansch	Flangia B5	Bride B5	Brida B5
07	B14 Motor Bağlantı Flanşı	B14 Flange	B14 Flansch	Flangia B14	Bride B14	Brida B14
08	Ayak	Foot	Fuß	Piede	Pied	Pie
09	Motor Mili (Standart)	Drive Shaft (standard)	Antriebswelle (standart)	Albero motore (standard)	Arbre moteur (la norme)	eje motor (estándar)
10	Fan Kapağı	Fan Cover	Lüfterhaube	Copriventola	Couvercle	versión de fan
11	Fan	Fan	Lüfter	Fan	Fan	Fan
12	Terminal Kutusu	Terminal Box	Klemmkasten	Morsettiera	Boîte à bornes	Caja de terminales
13	Terminal Kutu Kapağı	Terminal Box Cover	Klemmkastendeckel	Coperchio della morsettiera	Couvercle de la boîte à bornes	Cubierta de la caja de terminales
14	Klemens Plakası	Terminal Plate	Anschlussplatte	Piastra terminale	Plaque à bornes	Placa de terminales
15	Terminal Contası Alt	Terminal Gasket Down	Klemmkastendichtung unten	Sigillo terminale - giù	Joint de borne - bas	Junta de terminal - inferior
16	Terminal Contası Üst	Terminal Gasket Up	Klemmkastendichtung oben	Sigillo terminale - su	Joint de borne - haut	Junta de terminal - superior
17	Kablo Grubu	Lead Cables	Kabelbaum	Cavi di piombo	Câbles de plomb	Cables de plomo
18	Ön Rulman	Bal Bearing (Drive-Side)	Kugellager (Antriebsseite)	Cuscinetto (fronte)	Roulement (avant)	Cojinete (delantero)
19	Arka Rulman	Bal Bearing (Non-Drive-Side)	Kugellager (Nicht-Antriebsseite)	Cuscinetto (retro)	Roulement (arrière)	Cojinete (trasero)
20	Keçe (Ön)	Seal Ring (Front)	Dichtungsring (Vorne)	Anello di tenuta (anteriore)	Bague d'étanchéité (avant)	Anillo de sellado (delantero)
21	Keçe (Arka)	Seal Ring (Back)	Dichtungsring (Hinten)	anello di tenuta (posteriore)	Bague d'étanchéité (arrière)	Anillo de sellado (trasero)
22	Rulman Gergi Yayı	Bearing Shim	Stützscheibe	molla del cuscinetto	ressort de roulement	resorte rodante
23	Rakor	Conduit	Gewindemuffe	presa filettata	douille fileté	casquillo roscado
24	Kama	Key	Passfeder	Chiavetta	Clavette	Clave
25	Mapa	Eye Bolt	Augenschraube	vite ad anello	anneau de levage	Perno de anilla
26	Yıldız Başlı Civata	Pan Head Screws	Kreuzschlitzschraube	Viti a Stella	Vis étoile	tornillo de estrella
27	Yıldız Başlı Civata	Pan Head Screws	Kreuzschlitzschraube	Viti a Stella	Vis étoile	tornillo de estrella
28	Civata DIN 933	Bolt	Schraube DIN 933	Bullone	Boulonner	Atornillar
29	Civata DIN 933	Bolt	Schraube DIN 933	Bullone	Boulonner	Atornillar
30	Civata DIN 933	Bolt	Schraube DIN 933	Bullone	Boulonner	Atornillar
31	Civata DIN 912	Bolt	Schraube DIN 912	Bullone	Boulonner	Atornillar
32	Somun	Nut	Schraubenmutter	Dado	Ecrou	Tuerca

TR FRENLİ B3-B5-B14 FLANŞLI MOTOR PARÇA LİSTESİ
IT FRENO B3-B5-B14 ELENCO PARTI MOTORE FLANGIA

EN BRAKE B3-B5-B14 FLANGE MOTOR PART LIST
FR FREIN B3-B5-B14 BRIDE MOTEUR LISTE DES PIÈCES

DE ERSATZTEILLISTE FÜR MOTOR MIT BREMSE UND B3-B5-B14-FLANSCH
ES FRENO B3-B5-B14 BRIDA LISTA DE PIEZAS DEL MOTOR

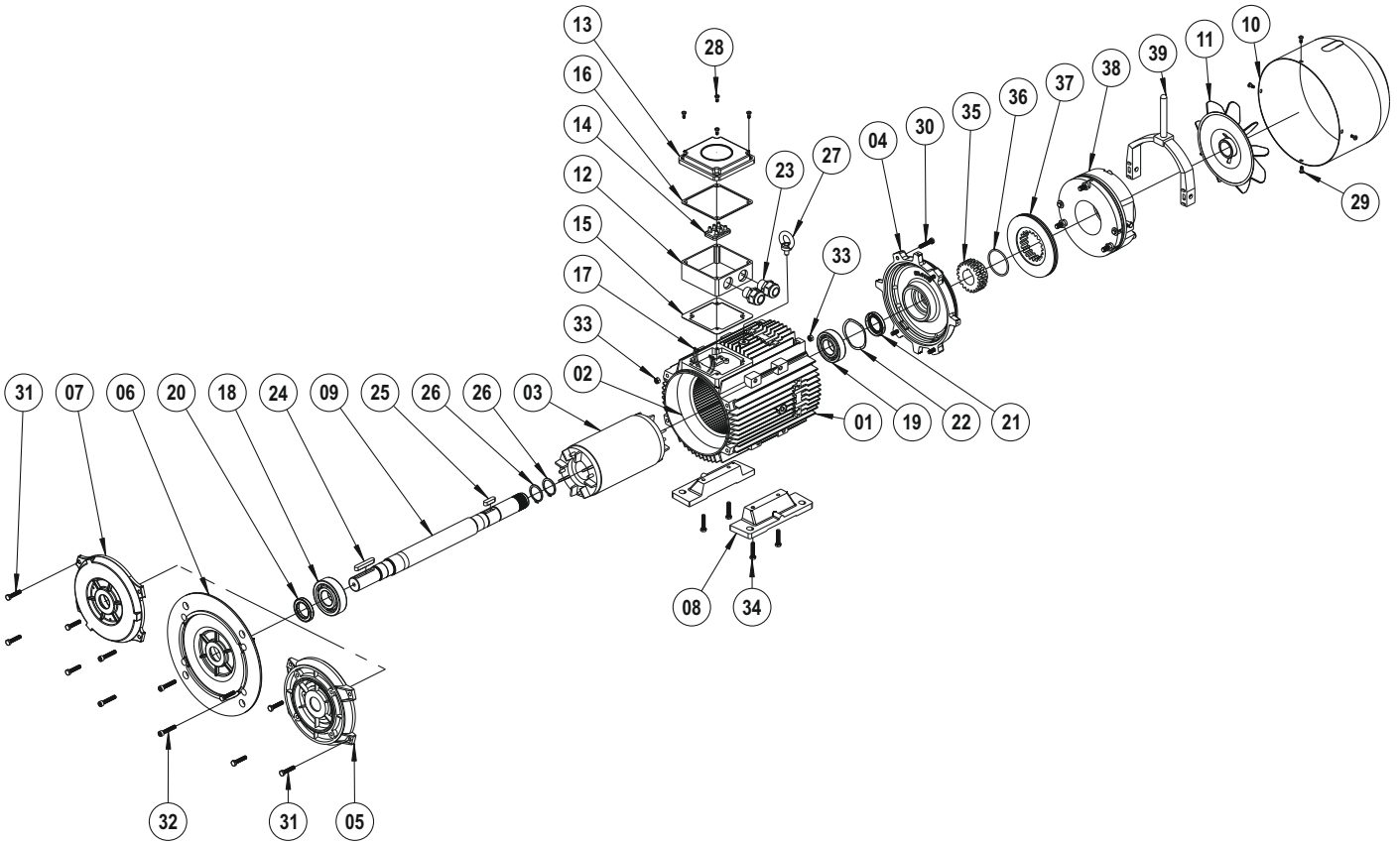

01	Gövde	Housing	Gehäuse	Involucro	corps	cuerpo
02	Sargılı Stator	Wound Stator	gewickelter Stator	Statore	Stator	Stator
03	Rotor	Rotor	Rotor	Rotore	Rotor	Rotor
04	Fren Flanşı	Brake Connection Flange	Bremsflansch	Flangia di collegamento del freno	Bride de connexion de frein	Brida de conexión de freno
05	B3 Motor Bağlantı Flanşı	B3 Flange	B3 Flansch	Flangia B3	Bride B3	Brida B3
06	B5 Motor Bağlantı Flanşı	B5 Flange	B5 Flansch	Flangia B5	Bride B5	Brida B5
07	B14 Motor Bağlantı Flanşı	B14 Flange	B14 Flansch	Flangia B14	Bride B14	Brida B14
08	Ayak	Foot	Fuß	Piede	Pied	Pie
09	Motor Mili (Standart)	Drive Shaft (standard)	Antriebswelle (standart)	Albero motore (standard)	Arbre moteur (la norme)	eje motor (estándar)
10	Fan Kapağı	Fan Cover	Lüfterhaube	Coperchiotola	Couvercle	versión de fan
11	Fan	Fan	Lüfter	Fan	Fan	Fan
12	Terminal Kutusu	Terminal Box	Klemmkasten	Morsettiera	Boîte à bornes	Caja de terminales
13	Terminal Kutu Kapağı	Terminal Box Cover	Klemmkastendeckel	Coperchio della morsettiera	Couvercle de la boîte à bornes	Cubierta de la caja de terminales
14	Klemens Plakası	Terminal Plate	Anschlussplatte	Piastra terminale	Plaque à bornes	Placa de terminales
15	Terminal Contası Alt	Terminal Gasket Down	Klemmkastendichtung unten	Sigillo terminale - giù	Joint de borne - bas	Junta de terminal - inferior
16	Terminal Contası Üst	Terminal Gasket Up	Klemmkastendichtung oben	Sigillo terminale - su	Joint de borne - haut	Junta de terminal - superior
17	Kablo Grubu	Lead Cables	Kabelbaum	Cavi di piombo	Câbles de plomb	Cables de plomo
18	Ön Rulman	Bal Bearing (Drive-Side)	Kugellager (Antriebsseite)	Cuscinetto (fronte)	Roulement (avant)	Cojinete (delantero)
19	Arka Rulman	Bal Bearing (Non-Drive-Side)	Kugellager (Nicht-Antriebsseite)	Cuscinetto (retro)	Roulement (arrière)	Cojinete (trasero)
20	Keçe (Ön)	Seal Ring (Front)	Dichtungsring (Vorne)	Anello di tenuta (anteriore)	Bague d'étanchéité (avant)	Anillo de sellado (delantero)
21	Keçe (Arka)	Seal Ring (Back)	Dichtungsring (Hinten)	anello di tenuta (posteriore)	Bague d'étanchéité (arrière)	Anillo de sellado (trasero)
22	Rulman Gergi Yayı	Bearing Shim	Stützscheibe	molla del cuscinetto	ressort de roulement	resorte rodante
23	Rakor	Conduit	Gewindemuffe	presa filettata	douille fileté	casquillo roscado
24	Kama	Key	Passfeder	Chiavetta	Clavette	Clave
25	Kama	Key	Passfeder	Chiavetta	Clavette	Clave
26	Segman	Circlip DIN 471	Sicherungsring DIN 471	Anello di sicurezza DIN 471	Circlip DIN 471	Anillo de seguridad DIN 471
27	Mapa	Eye Bolt	Augenschraube	vite ad anello	anneau de levage	Perno de anilla
28	Yıldız Başlı Civata	Pan Head Screws	Kreuzschlitzschraube	Viti a Stella	Vis étoile	tornillo de estrella
29	Yıldız Başlı Civata	Pan Head Screws	Kreuzschlitzschraube	Viti a Stella	Vis étoile	tornillo de estrella
30	Civata DIN 933	Bolt	Schraube DIN 933	Bullone	Boulonner	Atornillar
31	Civata DIN 933	Bolt	Schraube DIN 933	Bullone	Boulonner	Atornillar
32	Civata DIN 912	Bolt	Schraube DIN 912	Bullone	Boulonner	Atornillar
33	Somun	Nut	Schraubenmutter	Dado	Ecrou	Tuerca
34	Civata DIN 933	Bolt	Schraube DIN 933	Bullone	Boulonner	Atornillar
35	Fren Kaplini	Coupling	Kupplung	Accoppiamento	Couplage	Acoplamiento
36	O-Ring	O-Ring	O-Ring	O-Ring	O-Ring	O-Ring
37	Fren Balatası	Brake Lining	Bremsbelag	Guarnizioni dei freni	Garniture de frein	Romper el forro
38	Fren	Brake	Bremse	freno	Frein	Freno
39	Manuel Kolu	Hand Release	Handauslöser	Leva manuale	Levier manuel	Palanca manual

TR MOTOR PARÇA LİSTESİ

EN MOTOR PART LIST

DE ERSATZTEILLISTE FÜR MOTOR

IT ELENCO PARTI MOTORE

FR LISTE DES PIÈCES DU MOTEUR

ES LISTA DE PIEZAS DEL MOTOR

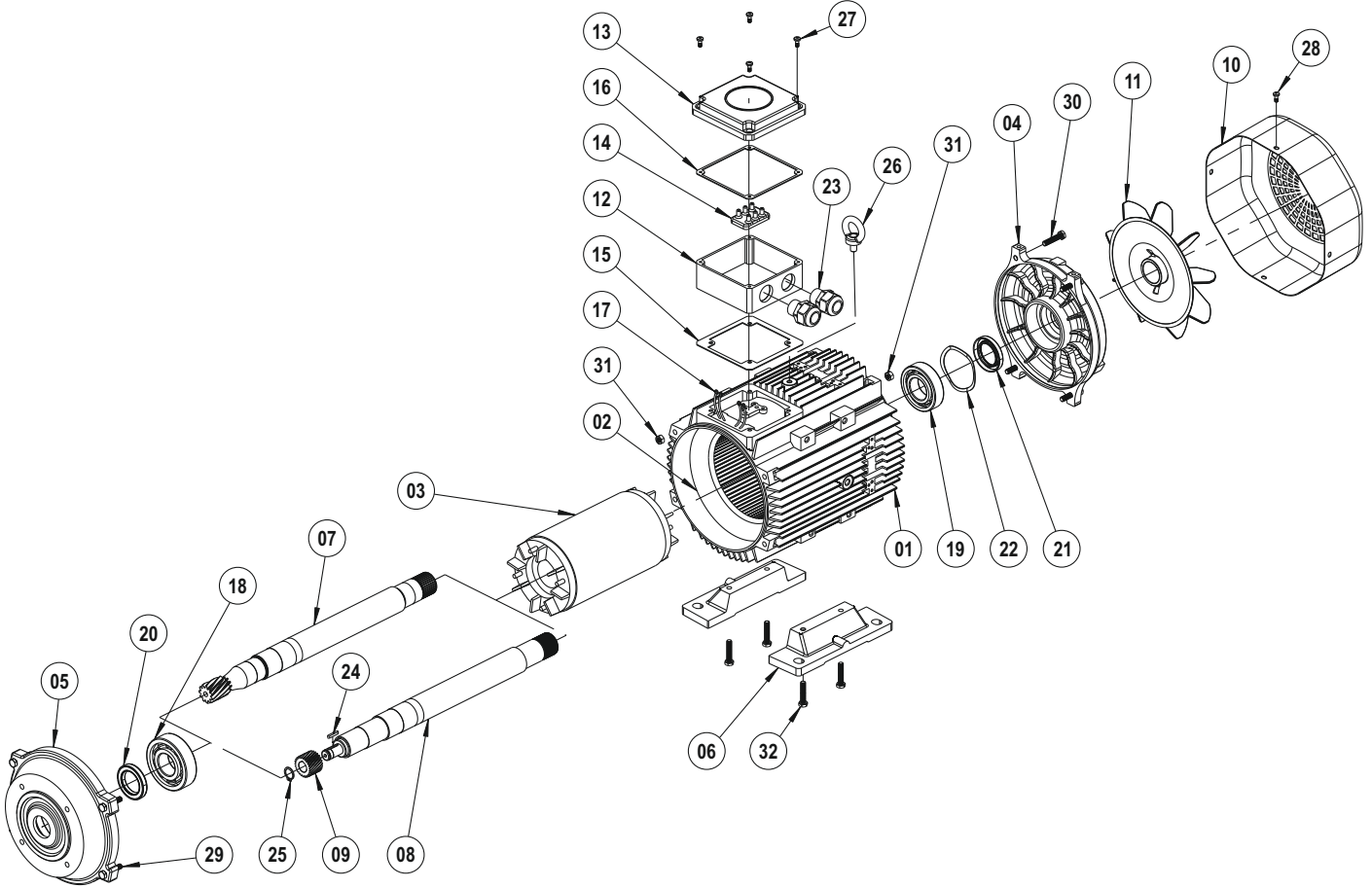

01	Gövde	Housing	Gehäuse	Involucro	corps	cuerpo
02	Sargılı Stator	Wound Stator	gewickelter Stator	Statore	Stator	Stator
03	Rotor	Rotor	Rotor	Rotore	Rotor	Rotor
04	Motor Arka Kapağı	Nondrive - Endshield	B-Lagerschild	Portellone motore	Portellone motore	Tapa trasera del motor
05	Motor Bağlantı Flanşı	Motor Connection Flange	Moter-Anschlussflansch	Flangia di collegamento del motore	Bride de raccordement moteur	Brida de conexión del motor
06	Ayak	Foot	Fuß	Piede	Pied	Pie
07	Motor Mili (Yekpare)	Drive Shaft (Gearcut)	Antriebswelle (verzahnt)	Albero motore (monolithic)	Arbre moteur (monolithique)	eje motor (monolítico)
08	Motor Mili (Çakma)	Drive Shaft (Plain)	Antriebswelle (glatt)	Albero motore (dritto)	Arbre moteur (lisse)	eje motor (suave)
09	Z1 Dişlisi	Z1 Gear	Antriebsritzel	Ingresso Pignone	Pignon d'entrée	Piñón de entrada
10	Fan Kapağı	Fan Cover	Lüfterhaube	Copriventola	Couvercle	versión de fan
11	Fan	Fan	Lüfter	Fan	Fan	Fan
12	Terminal Kutusu	Terminal Box	Klemmkasten	Morsetiera	Boîte à bornes	Caja de terminales
13	Terminal Kutu Kapağı	Terminal Box Cover	Klemmkastendeckel	Coperchio della morsetiera	Couvercle de la boîte à bornes	Cubierta de la caja de terminales
14	Klemens Plakası	Terminal Plate	Anschlussplatte	Piastra terminale	Plaque à bornes	Placa de terminales
15	Terminal Contası Alt	Terminal Gasket Down	Klemmkastendichtung unten	Sigillo terminale - giù	Joint de borne - bas	Junta de terminal - inferior
16	Terminal Contası Üst	Terminal Gasket Up	Klemmkastendichtung oben	Sigillo terminale - su	Joint de borne - haut	Junta de terminal - superior
17	Kablo Grubu	Lead Cables	Kabelbaum	Cavi di piombo	Câbles de plomb	Cables de plomo
18	Ön Rulman	Bal Bearing (Drive-Side)	Kugellager (Antriebsseite)	Cuscinetto (fronte)	Roulement (avant)	Cojinete (delantero)
19	Arka Rulman	Bal Bearing (Non-Drive-Side)	Kugellager (Nicht-Antriebsseite)	Cuscinetto (retro)	Roulement (arrière)	Cojinete (trasero)
20	Keçe (Ön)	Seal Ring (Front)	Dichtungsring (Vorne)	Anello di tenuta (anteriore)	Bague d'étanchéité (avant)	Anillo de sellado (delantero)
21	Keçe (Arka)	Seal Ring (Back)	Dichtungsring (Hinten)	anello di tenuta (posteriore)	Bague d'étanchéité (arrière)	Anillo de sellado (trasero)
22	Rulman Gergi Yayı	Bearing Shim	Stützscheibe	molla del cuscinetto	ressort de roulement	resorte rodante
23	Rakor	Conduit	Gewindemuffe	presa filettata	douille fileté	casquillo roscado
24	Kama	Key	Passfeder	Chiavetta	Clavette	Clave
25	Segman	Circlip DIN 471	Sicherungsring DIN 471	Anello di sicurezza DIN 471	Circlip DIN 471	Anillo de seguridad DIN 471
26	Mapa	Eye Bolt	Augenschraube	vite ad anello	anneau de levage	Perno de anilla
27	Yıldız Başlı Civata	Pan Head Screws	Kreuzschlitzschraube	Viti a Stella	Vis étoile	tornillo de estrella
28	Yıldız Başlı Civata	Pan Head Screws	Kreuzschlitzschraube	Viti a Stella	Vis étoile	tornillo de estrella
29	Civata DIN 933	Bolt	Schraube DIN 933	Bullone	Boulonner	Atornillar
30	Civata DIN 933	Bolt	Schraube DIN 933	Bullone	Boulonner	Atornillar
31	Somun	Nut	Schraubenmutter	Dado	Ecrou	Tuerca
32	Civata DIN 933	Bolt	Schraube DIN 933	Bullone	Boulonner	Atornillar

TR FRENLİ MOTOR PARÇA LİSTESİ

EN BRAKE MOTOR PART LIST

DE ERSATZTEILLISTE FÜR MOTOR MIT BREMSE

IT ELENCO DELLE PARTI DEL MOTORE DEL FRENO

FR LISTE DES PIÈCES DU MOTEUR DE FREIN

ES LISTA DE PIEZAS DEL MOTOR DE FRENO

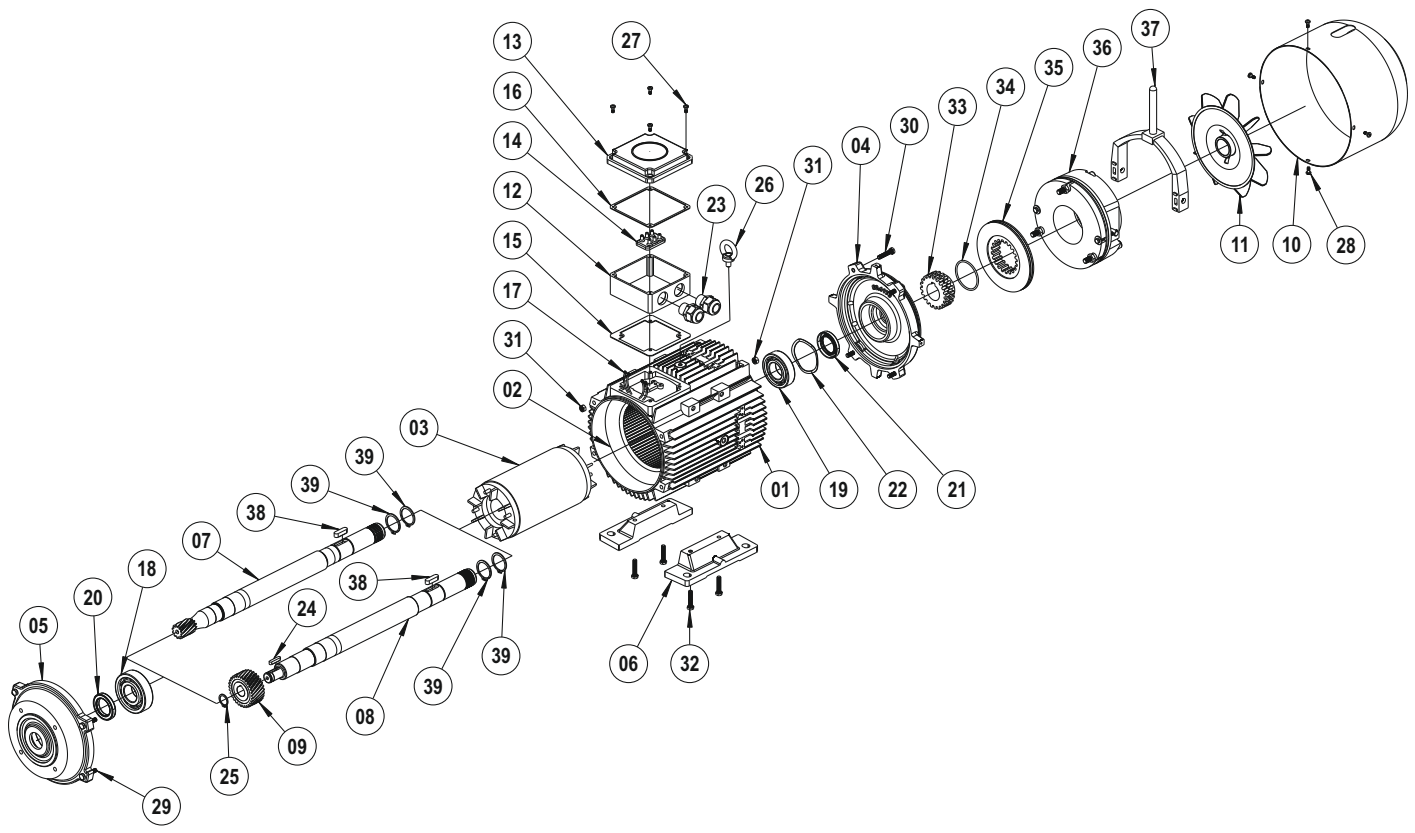

01	Gövde	Housing	Gehäuse	İnvolucro	corps	cuerpo
02	Sargılı Stator	Wound Stator	gewickelter Stator	Statore	Stator	Stator
03	Rotor	Rotor	Rotor	Rotore	Rotor	Rotor
04	Fren Flaşı	Brake Connection Flange	Bremsflansch	Flangia di collegamento del freno	Bride de connexion de frein	Brida de conexión de freno
05	Motor Bağlantı Flaşı	Motor Connection Flange	Moter-Anschlussflansch	Flangia di collegamento del motore	Bride de raccordement moteur	Brida de conexión del motor
06	Ayak	Foot	Fuß	Piede	Pied	Pie
07	Motor Mili (Yekpare)	Drive Shaft (Gearcut)	Antriebswelle (verzahnt)	Albero motore (monolithic)	Arbre moteur (monolithique)	eje motor (monolítico)
08	Motor Mili (Çakma)	Drive Shaft (Plain)	Antriebswelle (glatt)	Albero motore (dritto)	Arbre moteur (lisse)	eje motor (suave)
09	Z1 Dişlisi	Z1 Gear	Antriebsritzel	Ingresso Pignone	Pignon d'entrée	Piñón de entrada
10	Fan Kapağı	Fan Cover	Lüfterhaube	Copriventola	Couvercle	versión de fan
11	Fan	Fan	Lüfter	Fan	Fan	Fan
12	Terminal Kutusu	Terminal Box	Klemmkasten	Morsettiera	Boîte à bornes	Caja de terminales
13	Terminal Kutu Kapağı	Terminal Box Cover	Klemmkastendeckel	Coperchio della morsettiera	Couvercle de la boîte à bornes	Cubierta de la caja de terminales
14	Klemens Plakası	Terminal Plate	Anschlussplatte	Piastra terminale	Plaque à bornes	Placa de terminales
15	Terminal Contası Alt	Terminal Gasket Down	Klemmkastendichtung unten	Sigillo terminale - giù	Joint de borne - bas	Junta de terminal - inferior
16	Terminal Contası Üst	Terminal Gasket Up	Klemmkastendichtung oben	Sigillo terminale - su	Joint de borne - haut	Junta de terminal - superior
17	Kablo Grubu	Lead Cables	Kabelbaum	Cavi di piombo	Câbles de plomb	Cables de plomo
18	Ön Rulman	Bal Bearing (Drive-Side)	Kugellager (Antriebsseite)	Cuscinetto (fronte)	Roulement (avant)	Cojinete (delantero)
19	Arka Rulman	Bal Bearing (Non-Drive-Side)	Kugellager (Nicht-Antriebsseite)	Cuscinetto (retro)	Roulement (arrière)	Cojinete (trasero)
20	Keçe (Ön)	Seal Ring (Front)	Dichtungsring (Vorne)	Anello di tenuta (anteriore)	Bague d'étanchéité (avant)	Anillo de sellado (delantero)
21	Keçe (Arka)	Seal Ring (Back)	Dichtungsring (Hinten)	anello di tenuta (posteriore)	Bague d'étanchéité (arrière)	Anillo de sellado (trasero)
22	Rulman Gergi Yayı	Bearing Shim	Stützscheibe	molla del cuscinetto	ressort de roulement	resorte rodante
23	Rakor	Conduit	Gewindemuffe	presa filettata	douille fileté	casquillo roscado
24	Kama	Key	Passfeder	Chiavetta	Clavette	Clave
25	Segman	Circlip DIN 471	Sicherungsring DIN 471	Anello di sicurezza DIN 471	Circlip DIN 471	Anillo de seguridad DIN 471
26	Mapa	Eye Bolt	Augenschraube	vite ad anello	anneau de levage	Perno de anilla
27	Yıldız Başlı Civata	Pan Head Screws	Kreuzschlitzschraube	Viti a Stella	Vis étoile	tornillo de estrella
28	Yıldız Başlı Civata	Pan Head Screws	Kreuzschlitzschraube	Viti a Stella	Vis étoile	tornillo de estrella
29	Civata DIN 933	Bolt	Schraube DIN 933	Bullone	Boulonner	Atornillar
30	Civata DIN 933	Bolt	Schraube DIN 933	Bullone	Boulonner	Atornillar
31	Somun	Nut	Schraubenmutter	Dado	Ecrou	Tuerca
32	Civata DIN 933	Bolt	Schraube DIN 933	Bullone	Boulonner	Atornillar
33	Fren Kaplini	Coupling	Kupplung	Accoppiamento	Couplage	Acoplamiento
34	O-Ring	O-Ring	O-Ring	O-Ring	O-Ring	O-Ring
35	Fren Balatası	Brake Lining	Bremsbelag	Guarnizioni dei freni	Garniture de frein	Romper el forro
36	Fren	Brake	Bremse	freno	Frein	Freno
37	Manuel Kolu	Hand Release	Handauslöser	Leva manuale	Levier manuel	Palanca manual
38	Kama	Key	Passfeder	Chiavetta	Clavette	Clave
39	Segman	Circlip DIN 471	Sicherungsring DIN 471	Anello di sicurezza DIN 471	Circlip DIN 471	Anillo de seguridad DIN 471

TR FREN PARÇA LİSTESİ

EN BRAKE PART LIST

DE BREMSE-TEILELISTE

IT ELENCO DELLE PARTI DEL FRENO

FR LISTE DES PIÈCES DE FREIN

ES LISTA DE PIEZAS DE FRENO

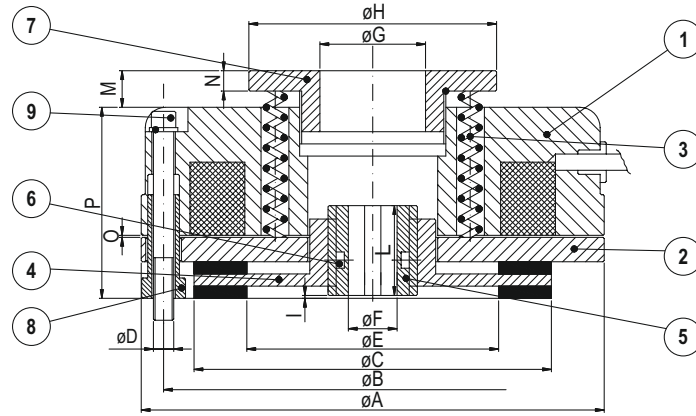

- | | | | | | |
|-----------------------|----------------|-------------------|-----------------------|--------------------|-----------------------|
| 1 Elektromagnet | Electromagnet | Elektromagnet | Elettromagnete | Électro-aimant | Electroímán |
| 2 Endüvi plakası | Armature plate | Ankerplatte | Piastra dell'armatura | Plaque d'induit | Placa de armadura |
| 3 Tork yayı | Torque springs | Bremsfeder | Molle di coppia | Ressorts de couple | Muelles de torsión |
| 4 Disk | Disc | Scheibe | Disco | Disque | Dto |
| 5 Kamalı burç | Splined hub | Nabe | Mozzo scanalato | Moyeu cannelé | Cubo estriado |
| 6 O-ring | O-ring | O-Ring | O-ring | O-ring | O-ring |
| 7 Ayar halkası | Adjuster rings | Einstellring | Anelli di regolazione | Anneaux de réglage | Anillos de ajuste |
| 8 Ayar somunu | Adjuster nuts | Einstellschraube | Dadi di regolazione | Écrous de réglage | Tuercas de ajuste |
| 9 Bağlantı civataları | Fixing screws | Feststellschraube | Viti di fissaggio | Vis de fixation | Tornillos de fijación |

Tip / Type / Typ / Tipo / Type / Tipo Fren Modeli / Brake Model / Bremsmodell / Modello di freno / Modèle de frein / Modelo de freno	K1	K2	K3	K4	K5	K6	K7	K7/D	K8	K8/D	K9	K9/D	K9/T	
Statik Fren Momenti / Static Braking Torque / Statisches Bremsmoment / Coppia frenante statica / Couple de freinage statique / Par de frenado estático	(Nm)	5	12	16	20	40	60	90	180	200	400	300	600	900
Motorun Max. Hızı / Max Speed of the motor / Höchstgeschwindigkeit des Motors / Velocità massima del motore / Vitesse max. du moteur / Velocidad máxima del motor	(rpm)	3000	3000	3000	3000	3000	3000	3000	3000	1500	1500	1500	1500	1500
Giriş Gücü / Input Power / Eingangsleistung / Potenza di ingresso / La puissance d'entrée / Potencia de entrada	(W)	15	20	25	30	45	50	55	55	60	60	65	65	65
Max. Ses / Max noisiness / Maximale lautheit / Rumorosità massima / Bruit maximum / Máximo ruido	(≤dB-A)	68	69	68	69	70	70	70	70	70	69	69	69	70
Ağırlık / Weight / Gewicht / peso / poids / peso	(Kg.)	1,1	1,85	2,55	2,84	4,8	7	12	15	14,3	18	23	28	34
A		84	104	114	124	148	159	189	189	218	218	248	248	248
B		72	90	103	112	132	145	170	170	196	196	230	230	230
C		61	77	88	98	119	128	151	151	176	176	204	204	204
D		3xM4	3xM5	3xM5	3xM6	3xM6	3xM8	3xM8	3xM8	6xM10	6xM10	6xM10	6xM10	9xM10
Delik toleransı K3'e kadar H7, diğerleri + 0,01/-0,01 Tolerance hole till size K3 H7, others + 0,01/-0,01 Bohrungstoleranz bis Grösse K3 H7, andere + 0,01/-0,01 Tolleranza foro fino alla misura K3 H7, altri + 0,01/-0,01 Tolérance trou jusqu'à la taille K3 H7, autres + 0,01/-0,01 Tolerancia agujero hasta tamaño K3 H7, otros + 0,01/-0,01	E	35	44	62	69	79	80	90	90	103	103	132	132	132
F		10-11 12	11-14 15	11-15	14-25	24-25 28	25-30 34	25-30 34	25 H40 34 H60	24-34	34 H60 48	44-45 48	44-45 48	44-45 48-50
G		20	26	26	42	60	60	60	60	60	60	60	60	60
H		50	61	61	79	104	104	104	104	104	104	104	104	104
I		1,5	1,5	1,5	1,5	1,5	1,5	1,5	1,5	1,5	1,5	1,5	1,5	1,5
L		18	20	20	20	25	30	30	60	40	60	40	60	80
M (max)		9	9	9	9,5	18	16	14	14	18	18	18	18	18
N		4	4	4	5,5	8	8	8	8	8	8	8	8	8
O		0,2	0,2	0,2	0,2	0,3	0,3	0,3	0,3	0,3	0,4	0,4	0,4	0,4+0,5
P		38,5	41,5	47	46,5	64	69,5	79	101,5	78	98	80	105	130

Not : Fren çalıştırılmadan önce statik fren momenti tabloda verilen değerlere göre ± % 20 değişiklik gösterebilir.
Note : The brake before running in, the static braking torque value could change by +20% from the reported value.
Notizen : Bevor die Bremse eingefahren ist, kann das statische Bremsmoment um etwa ± 20 % vom Tabellenwert abweichen.
Nota : Il freno prima del rodaggio, il valore della coppia frenante statica potrebbe variare del +20% dal valore riportato.
Nota : Le frein avant rodage, la valeur du couple de freinage statique peut varier de +20% par rapport à la valeur reportée.
Nota : El valor del par de frenado estático antes de la puesta en marcha del freno podría cambiar en un +20 % con respecto al valor informado.



A series of horizontal dotted lines spanning the width of the page, intended for writing or drawing.



POLAT GROUP REDÜKTÖR SAN. ve TİC. A.Ş.

- ATA OSB Mah. Astim 1.Cad. No: 4 Efeler - Aydın / TÜRKİYE
- T: +90 256 231 19 12 • F: +90 256 231 19 17 • info@pgr.com.tr • www.pgr.com.tr