

Sonsuz Dişli Redüktör

Worm Gear Units

PMRV/PRV SERIES

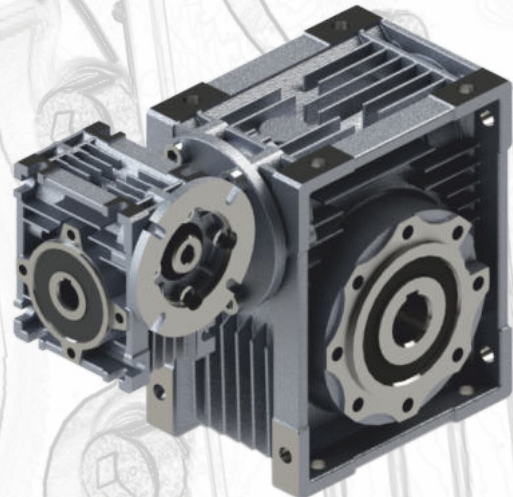

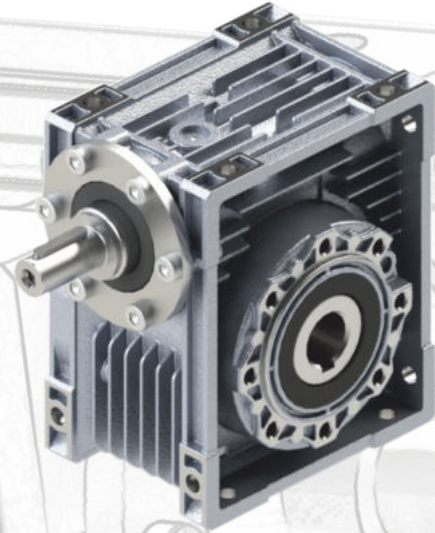
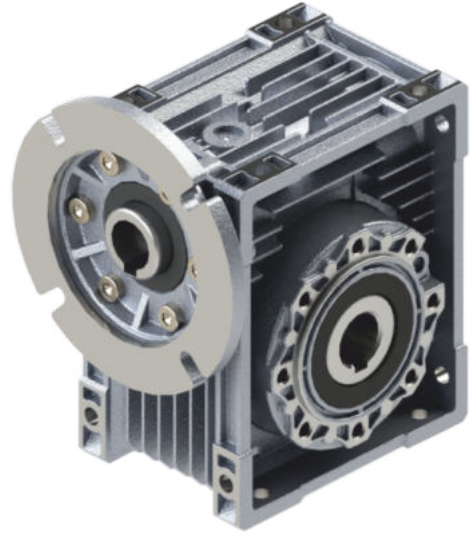

Katalođumuzda yer alan bilgileri, önceden haber vermeksizin kısmen veya tamamen deđiřtirme veya iptal etme hakkını saklı tutmaktayız.  
We reserve the right to our company to make changes or modifications to catalogue without prior notice.

**PGR<sup>®</sup>**  
**DRIVE TECHNOLOGIES**



**İÇİNDEKİLER / CONTENTS / INHALT / INDICE / INDEX / INDICE**

<b>Semboller / Symbols / Zeichen / Simbologia / Symboles / Simbologia</b> .....	<b>3</b>
<b>Servis faktörü / Service factor / Betriebsfaktor / Fattore si servizio / Facteur de service / Factor de servicio</b> .....	<b>4 - 5</b>
<b>Kritik uygulamalar / Critical applications / Kritische anwendungen / Applicazioni critiche / Applications critiques / Applicaciones críticas</b> .....	<b>6 - 7</b>
<b>Montaj / Installation / Montage / Installazione / Installation / Instalación</b> .....	<b>8 - 9</b>
<b>PAM B5 Flanşı ile Motor Montajı / Motor mounting with PAM flange B5 / Montage des moteurs an den PAM - flansch B5 / Montaggio motore su flange PAM B5 / Installation moteur sur bride PAM B5 / Montaje de motores con brida B5</b> .....	<b>10</b>
<b>Radyal yükler / Radial loads / Querbelastungen / Carichi radiali / Charges radiales / Cargas radiales</b> .....	<b>11 - 14</b>
<b>Yağlama / Lubrication / Schmierung / Lubrificazione / Lubrification / Lubricación</b> .....	<b>15 - 17</b>
<b>Yüzey işleme özellikleri / Surface treatment specifications / Spezifikation der oberflächenbehandlung / Specifiche di finitura superficiale / Spécifications sur l'aspect extérieur / Características de suministro superficial</b> .....	<b>18 - 19</b>
<b>Tasarım / Designation / Bezeichnung / Designazione / Désignation / Designación</b> .....	<b>22 - 24</b>
<b>Prepozisyonlama / Predisposition / Motoranbau / Predisposizione / Prédiposition / Predisposición</b> .....	<b>25</b>
<b>Kombinasyon / Combinations / Kombinationen / Combinazioni / Combinaisons / Combinaciones</b> .....	<b>26</b>
<b>Versiyonlar / Versions / Ausführungen / Versioni / Versions / Versiones</b> .....	<b>27</b>
<b>Verimlilik / Efficiency / Wirkungsgrad / Rendimento / Rendement / Rendimiento</b> .....	<b>28 - 29</b>
<b>Dişli Verisi / Mesh data / Verzahnungsdaten / Dati ingranamento / Données des engranages / Datos engrane</b> .....	<b>30</b>
<b>Dönüş Yönü / Direction of rotation / Drehsinn / Senso di rotazione / Sens de rotation / Sentido de rotacion</b> .....	<b>31</b>
<b>Tasarım Özellikleri (PPC) / Design Features / Baueigenschaften / Caratteristiche costruttive / Caractéristiques de construction / Características de construcción</b> .....	<b>32</b>
<b>Elektrik motoruna yapılan akuplaj / Coupling to electric motor / Montage des elektromotors / Montaggio motore elettrico / Montage du moteur électrique / Montaje motor electrico</b> .....	<b>33</b>
<b>Montaj pozisyonu / Mounting positions / Einbaulage / Piazzamento / Pos. de montage / Pos. de montaje</b> .....	<b>34</b>
<b>Uygulama / Execution / Paarungsform / Esecuzione / Exécution / Ejecución</b> .....	<b>35</b>
<b>PMRV Motorlu Seçim Tabloları / Selection Tables of Gearedmotors / Auswahltabellen der Getriebemotoren / Tabelle di selezione dei motoriduttori / Tables de Gearedmotors de sélection / Tablas de selección de gearedmotors</b> .....	<b>37 - 63</b>
<b>PRV Performans Tabloları / Performance Tables / Leistungstabellen / Tabelle delle Prestazioni / Tableaux de Performance / Tablas de rendimiento</b> .....	<b>64 - 73</b>
<b>Ölçü Tabloları / Dimensions / Abmessungen / Dimensioni / Encombremets / Dimensiones</b> .....	<b>75 - 86</b>
<b>PPC+PMRV Ölçüleri / Dimensions / Abmessungen / Dimensioni / Encombremets / Dimensiones</b> .....	<b>87 - 91</b>
<b>PMRV+PMRV Ölçüleri / Dimensions / Abmessungen / Dimensioni / Encombremets / Dimensiones</b> .....	<b>92 - 95</b>
<b>Düşük Hızlı Şaftlar / Low speed shafts / Abtriebswellen / Alberi lenti / Arbres pv / Ejes lentos</b> .....	<b>96</b>
<b>Tork Kolu / Torque arm / Drehmomentstütze / Braccio di reazione / Bras de réaction / Brazo de reacción</b> .....	<b>97</b>
<b>Ölçüler / Dimensions / Abmessungen / Dimensioni / Encombremets / Dimensiones</b> .....	<b>98</b>
<b>PAM B5 - B14 Ölçüleri / Dimensions / Abmessungen / Dimensioni / Encombremets / Dimensiones</b> .....	<b>99</b>
<b>Elektrik Motoru / Electrical Motor / Elektromotor / Motore elettrico / Moteur électrique / Motor eléctrico</b> .....	<b>100 - 103</b>
<b>PMRL Özellikleri / Features / Eigenschaften / Caratteristiche / Carateristiques / Características</b> .....	<b>104</b>
<b>PMRL Versiyonlar / Versions / Ausführungen / Versioni / Versions / Versiones</b> .....	<b>105 - 106</b>



A series of horizontal dotted lines spanning the width of the page, intended for writing or drawing.

SEMBOLLER / SYMBOLS / ZEICHEN / SIMBOLOGIA / SYMBOLES / SIMBOLOGIA

**Semboller**

<b>P</b> = Güç	(kW)	<b>1</b> = Giriş Şaftı
<b>M</b> = Moment	(Nm)	<b>2</b> = Çıkış Şaftı
<b>n</b> = Devir	(d/d)	<b>R</b> = Radyal
<b>i</b> = Tahvil Oranı		<b>A</b> = Eksenal
<b>F</b> = Kuvvet	(N)	<b>s</b> = Statik
<b>m</b> = Ağırlık	(kg)	<b>d</b> = Dinamik
<b>f<sub>B</sub></b> = Servis Faktörü		<b>max</b> = Maksimum
		<b>min</b> = Minimum

**Symbols**

<b>P</b> = Power	(kW)	<b>1</b> = Input shaft
<b>M</b> = Torque	(Nm)	<b>2</b> = Output shaft
<b>n</b> = Speed	(rpm)	<b>R</b> = Radial
<b>i</b> = Reduction ratio		<b>A</b> = Axial
<b>F</b> = Load	(N)	<b>s</b> = Static
<b>m</b> = Weight	(kg)	<b>d</b> = Dynamic
<b>f<sub>B</sub></b> = Service factor		<b>max</b> = Maximum
		<b>min</b> = Minimum

**Zeichen**

<b>P</b> = Leistung in	(kW)	<b>1</b> = Antriebswelle
<b>M</b> = Drehmoment in	(Nm)	<b>2</b> = Abtriebswelle
<b>n</b> = Drehzahl in	(rpm)	<b>R</b> = Radial
<b>i</b> = Übersetzung		<b>A</b> = Axial
<b>F</b> = Kraft in	(N)	<b>s</b> = Statisch
<b>m</b> = Masse in	(kg)	<b>d</b> = Dynamisch
<b>f<sub>B</sub></b> = Betriebsfaktor		<b>max</b> = Maximal
		<b>min</b> = Minimal

**Simbologia**

<b>P</b> = Potenza	(kW)	<b>1</b> = Albero ingresso
<b>M</b> = Momento torcente	(Nm)	<b>2</b> = Albero uscita
<b>n</b> = Numero giri	(giri / 1')	<b>R</b> = Radiale
<b>i</b> = Rapporto di riduzione		<b>A</b> = Assiale
<b>F</b> = Forza	(N)	<b>s</b> = Statico
<b>m</b> = Peso	(kg)	<b>d</b> = Dinamico
<b>f<sub>B</sub></b> = Fattore di servizio		<b>max</b> = Massimo
		<b>min</b> = Minimo

**Symboles**

<b>P</b> = Puissance	(kW)	<b>1</b> = Arbre d'entrée
<b>M</b> = Moment de torsion	(Nm)	<b>2</b> = Arbre de sortie
<b>n</b> = Nombre de tours	(tours/min)	<b>R</b> = Radial
<b>i</b> = Rapport de réduction		<b>A</b> = Axial
<b>F</b> = Force	(N)	<b>s</b> = Statique
<b>m</b> = Poids	(kg)	<b>d</b> = Dynamique
<b>f<sub>B</sub></b> = Facteur de service		<b>max</b> = Maximum
		<b>min</b> = Minimum

**Simbologia**

<b>P</b> = Potencia	(kW)	<b>1</b> = Eje de entrada
<b>M</b> = Momento torsor	(Nm)	<b>2</b> = Eje de salida
<b>n</b> = Número de revoluciones	(rpm)	<b>R</b> = Radial
<b>i</b> = Relación de reducción		<b>A</b> = Axial
<b>F</b> = Fuerza	(N)	<b>s</b> = Estático
<b>m</b> = Peso	(kg)	<b>d</b> = Dinámico
<b>f<sub>B</sub></b> = Factor de servicio		<b>max</b> = Máximo
		<b>min</b> = Mínimo

## TR SERVİS FAKTÖRÜ

Servis faktörü (fb) redüktörün maruz kaldığı çalışma koşullarına göre değişkenlik gösterir. En etkin servis faktörünü seçmek için göz önüne alınması gereken parametreler aşağıdaki hususlara bağlıdır:

- Çalışan makinadaki yükün tipi : **U-M-H**
- Günlük çalışma süresi : **saat / gün**
- Start-Stop sıklığı : **başlangıç / saat**

<b>YÜK TİPİ :</b>	<b>U-</b> Uniform yükler:	$mfa \leq 0.3$
	<b>M-</b> Orta seviyeli şoklar:	$mfa \leq 3$
	<b>H-</b> Ağır şoklar:	$mfa \leq 10$

**mfa = Je / Jm**

- mfa atalet faktörü
  - Je ( $kgm^2$ ) tahrik milindeki indirgenmiş harici atalet momenti
  - Jm ( $kgm^2$ ) motor atalet momenti
- Eğer mfa değeri > 10 ise durumu Teknik Servisimize bildirin.

**U-** Hafif malzemeler için vida besleme aparatları, fanlar, montaj hatları hafif malzemeler naklinde kullanılan kemerler, küçük mikserler, lifter temizleme makineleri, dolgu makineleri, kontrol makineleri.

**M-** Helezonlar, ağaç işleme makineleri, besleme aparatları, malzeme lift makineleri, balans makineleri, pafta makineleri, orta boy mikserler, ağır malzeme naklinde kullanılan kemerler, vinçler, raylı kapılar, suni gübre spatulası, paketleme makineleri, beton mikserleri, vinç mekanizmaları, freze makineleri, bükme-kıvrma makineleri, dişli pompalar.

**H-** Ağır malzemeler için mikserler, kırkma makası, presler, santrifüj makineleri, ayna destek aparatları, ağır malzemeler için lift ve vinçler, taşlama tezgahları, bileme taşları, pistonlu asansörler, matkap tezgahları, çekiç milleri, mil dirsek presleri, bükme-kıvrma makineleri, döner levhalar, silindir variller, vibratörler, kağıt öğütücüleri.

## EN SERVICE FACTOR

The service factor (fb) depends on the operating conditions the reduction unit is subjected to. The parameters that need to be taken into consideration to select the most adequate service factor correctly comprise:

- Type of load of the operated machine: **U - M - H**
- Length of daily operating time: **hours/day**
- Start-up frequency: **starts/hour**

<b>TYPE OF LOAD:</b>	<b>U-</b> Uniform	$mfa \leq 0.3$
	<b>M-</b> Moderate shocks	$mfa \leq 3$
	<b>H-</b> Heavy shocks	$mfa \leq 10$

**mfa = Je/Jm**

- mfa factor of inertia
  - Je ( $kgm^2$ ) moment of reduced external inertia at the drive shaft
  - Jm ( $kgm^2$ ) moment of inertia of motor
- If mfa > 10 call our Technical Service.

**U-** Screw feeders for light materials, fans, assembly lines, conveyor belts for light materials, small mixers, lifts, cleaning machines, fillers, control machines.

**M-** Winding devices, woodworking machine feeders, goods lifts, balancers, threading machines, medium mixers, conveyor belts for heavy materials, winches, sliding doors, fertilizer scrapers, packing machines, concrete mixers, crane mechanisms, milling cutters, folding machines, gear pumps.

**H-** Mixers for heavy materials, shears, presses, centrifuges, rotating supports, winches and lifts for heavy materials, grinding lathes, stone mills, bucket elevators, drilling machines, hammer mills, cam presses, folding machines, turntables, tumbling barrels, vibrators, shredders.

## DE BETRIEBSFAKTOR

Der Betriebsfaktor (fb) hängt von den Betriebsbedingungen, ab, unter denen das Getriebe betrieben wird. Die Parameter, die für eine korrekte Auswahl des Betriebsfaktors zu berücksichtigen sind, sind folgende:

- Belastungsart der angetriebenen Maschine: **U - M - H**
- Tägliche Betriebsdauer: **Std./Tag**
- Anlaufrequenz: **Anl./Std.**

<b>LAST:</b>	<b>U-</b> Gleichförmig	$mfa \leq 0.3$
	<b>M-</b> Mittlere Überlast	$mfa \leq 3$
	<b>H-</b> Hohe Überlast	$mfa \leq 10$

**mfa = Je/Jm**

- mfa Massenträgheitswert
  - Je ( $kgm^2$ ) äußeres Trägheitsmoment reduziert auf die Motorwelle
  - Jm ( $kgm^2$ ) Motor-Trägheitsmoment
- Bei mfa > 10 bitte mit unserem Kundendienst Kontakt aufnehmen.

**U-** Schneckenförderer für Leichtmaterial, Gebläse, Montagebänder, Bandförderer für Leichtmaterial, kleine Rührwerke, Kleinlastenaufzüge, Kreiselpumpen, Hebebühnen, Reinigungsmaschinen, Abfüllmaschinen, Prüfmaschinen, Bandförderer.

**M-** Wickelmaschinen, Vorrichtungen zur Zuführung bei Holzbearbeitungsmaschinen, Lastaufzüge, Auswuchtmaschinen, Gewindeschneidmaschinen, mittlere Rührwerke und Mischer, Bandförderer für schwere Materialien, Winden, Schiebetore, Dünger Abkratzer, Verpackungsmaschinen, Betonmischmaschinen, Kranfahrund Kranhubwerke, Fräsmaschinen, Biegemaschinen, Zahnradpumpen, Hubstapler, Drehtische.

**H-** Rührwerke für schwere Materialien, Scheren, Pressen, Schleudern, Winden und Aufzüge für schwere Materialien, Schleifmaschinen, Steinbrecher, Kettenbecherwerke, Bohrmaschinen, Hammernmühlen, Exzenterpressen, Biegemaschinen, Drehtische, Scheuertrommeln, Vibrationsrüttler, Schneidemaschinen, Stanzen, Walzwerke, Zementmühlen.

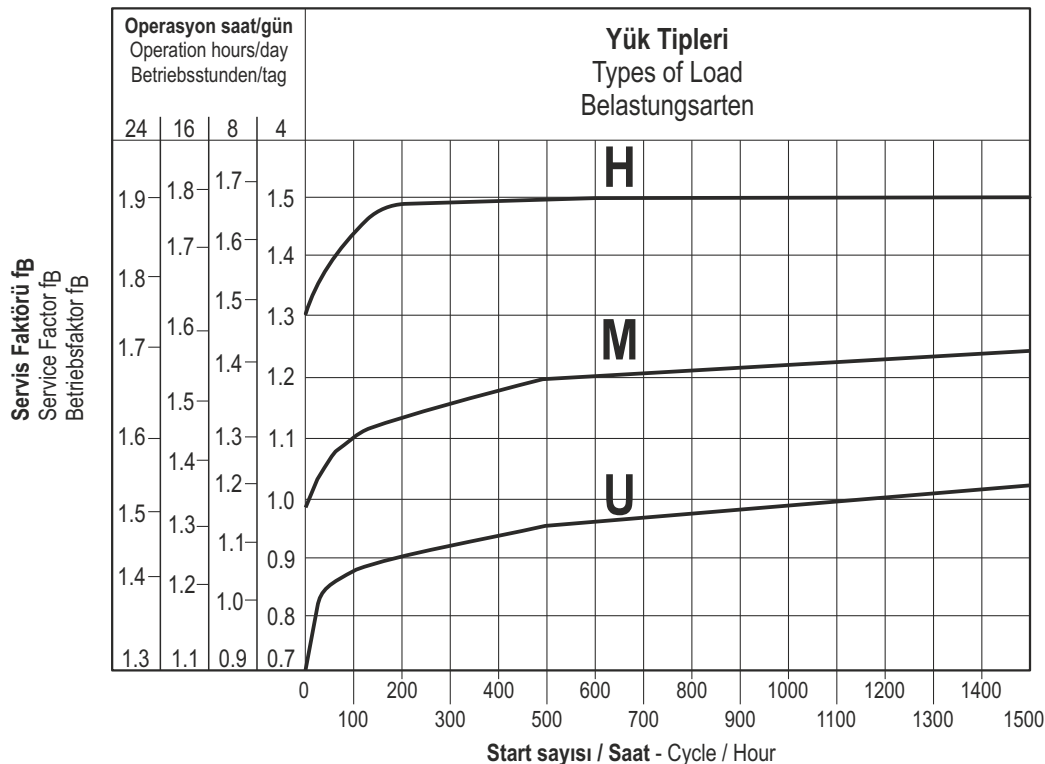



**IT** FATTORE DI SERVIZIO

Il fattore di servizio (fb) dipende dalle condizioni di funzionamento alle quali il riduttore è sottoposto. I parametri che occorre considerare per una corretta selezione del fattore di servizio più adeguato sono:

- Tipo del carico della macchina azionata: U-M-H
- Durata di funzionamento giornaliero: ore/giorno
- Frequenza di avviamento: avv/ora

<b>TIPO DEL CARICO:</b>	<b>U</b> - Uniforme	mfa ≤ 0.3
	<b>M</b> - Medio	mfa ≤ 3
	<b>H</b> - Forte	mfa ≤ 10

**mfa = Je/Jm**

- mfa fattore d'inerzia
  - Je (kgm<sup>2</sup>) momento d'inerzia esterno ridotto all'albero motore
  - Jm (kgm<sup>2</sup>) momento d'inerzia motore
- Se mfa > 10 interpellare il ns. Servizio Tecnico.

**U**- Cocolle per materiali leggeri, ventole, linee di montaggio, nastri trasportatori per materiali leggeri, piccoli agitatori, elevatori, macchine pulitrici, macchine riempitrici, macchine per il controllo, nastri trasportatori.

**M**- Dispositivi di avvolgimento, apparecchi per l'alimentazione delle macchine per il legno, montacarichi, equilibratrici, filettatrici, agitatori medi e mescolatori, nastri trasportatori per materiali pesanti, verricelli, porte scorrevoli, raschiatore di concime, macchine per l'imballaggio, betoniere, meccanismi per il movimento delle gru, frese, piegatrici, pompe a ingranaggi.

**H**- Agitatori per materiali pesanti, cesoie, prese, centrifughe, supporti rotanti, verricelli ed ascensori per materiali pesanti, torni per la rettifica, frantoi da pietre, elevatori a tazze, perforatrici, mulini a meartello, presse as eccentrico, piegatrici, tavoli rotanti, barilatrici, vibratorii, trinciatrici.

**FR** FACTEUR DE SERVICE

Le facteur de service (fb) est subordonné aux conditions de fonctionnement auxquelles le réducteur est soumis. Les paramètres qu'il faut considérer pour un choix correct du facteur de service adéquat sont les suivants:

- Type de charge de la machine actionnée: **U-M-H**
- Durée de fonctionnement journalière: **heures / jour**
- Fréquence de démarrage: **dém / heure**

<b>TYPE DE CHARGE:</b>	<b>U</b> - Uniforme	mfa ≤ 0.3
	<b>M</b> - Surcharge moyenne	mfa ≤ 3
	<b>H</b> - Surcharge forte	mfa ≤ 10

**mfa = Je/Jm**

- mfa facteur d'inertie
  - Je (kgm<sup>2</sup>) moment d'inertie extérieur ramené à l'arbre-moteur
  - Jm (kgm<sup>2</sup>) moment d'inertie moteur
- En cas de mfa > 10, contacter notre S.ce Technique.

**U**- Vis d'Archimède pour matériaux légers, ventilateurs, lignes de montage, convoyeurs pour matériaux légers, petits agitateurs, élévateurs, machines à nettoyer, machines à remplir, machines pour le contrôle, convoyeurs.

**M**- Dispositifs d'enroulement, appareils pour l'alimentation des machines pour le bois, monte-charge, équilibreuses, taraudeuses, agitateurs moyens et mélangeurs, convoyeurs pour matériaux lourds, treuils, portes coulissantes, racleurs d'engrais, machines à emballer, plieuses, pompes à engrenages.

**H**- Agitateurs pour matériaux lourds, cisailles, presses, centrifugeuses, supports rotatifs, treuils et ascenseurs pour matériaux lourds, tours pour la rectification, concasseurs de pierres, élévateurs à godets, perceuses, moulins à marteaux, presses à excentrique, plieuses, tables tournantes, polisseuses, vibreurs, machines à hacher.

**ES** FACTOR DE SERVICIO

El factor de servicio (fb) depende de las condiciones de funcionamiento a las cuales está sometido el reductor. Los parámetros que deben ser considerados para una correcta selección del factor de servicio más adecuado son:

- Tipo de carga de la máquina accionada: **U-M-H**
- Duración de funcionamiento diario: **horas/día**
- Frecuencia de arranques: **arr/hora**

<b>TIPO DE CARGA:</b>	<b>U</b> - Uniforme	mfa ≤ 0.3
	<b>M</b> - Sobrecarga media	mfa ≤ 3
	<b>H</b> - Sobrecarga fuerte	mfa ≤ 10

**mfa = Je/Jm**

- mfa factor de inercia
  - Je (kgm<sup>2</sup>) inercia externa reducida al eje motor
  - Jm (kgm<sup>2</sup>) inercia motor
- En caso de mfa > 10, ponerse en contacto con nuestro Servicio Técnico.

**U**- Tornillos de Arquimedes para materiales ligeros, ventiladores, líneas de montaje, cintas transportadoras para materiales ligeros, pequeños agitadores, elevadores, máquinas limpiadoras, máquinas llenadoras, máquinas comprobadoras, cintas transportadoras.

**M**- Dispositivos de enrollado, alimentadores de las máquinas para la madera, montacargas, equilibradores, roscadoras, agitadores medios y mezcladores, cintas transportadoras para materiales pesados, cabrestantes, puertas corredizas, raspadores de abono, máquinas empaquetadoras, puertas corredizas, raspadores de abono, máquinas empaquetadoras, hormigoneras, mecanismos para el movimiento de las grúas, fresadoras, plegadoras, bombas de engranajes.

**H**- Agitadores para materiales pesados, cizallas, prensas, centrifugadoras, soportes rotativos, cabrestantes y elevadores para materiales pesados, tornos para la rectificación, molinos de piedras, elevadores de cangilones, perforadoras, moledores a percusión, prensas de excéntrica, plegadoras, mesas giratorias, pulidoras, vibradores, cortadoras.

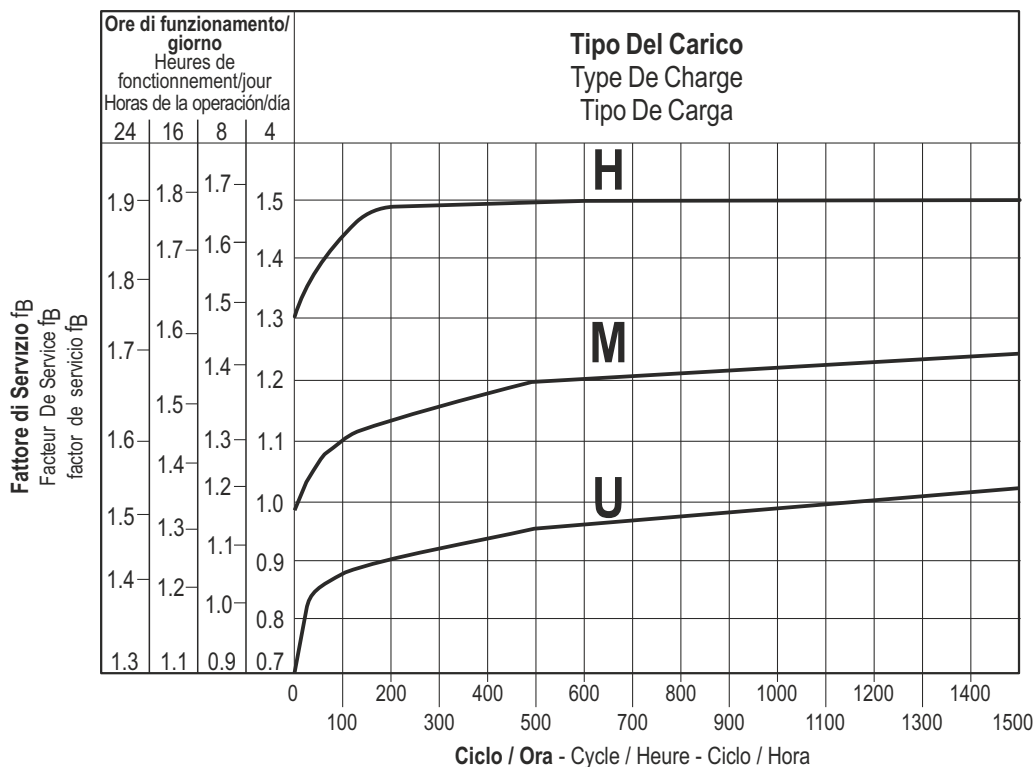

## TR KRİTİK UYGULAMALAR

Katalogta verilen performans değerleri B3 montaj pozisyonu ve buna benzer durumlar içindir. Örneğin: İlk kademe, komple yağ içinde olmadığı durumlarda. Diğer montaj pozisyonları değişik giriş hızları ve her bir redüktör gövdesi için kritik uygulama durumları tabloda sunulmuştur.

Aşağıdaki uygulamalar için de teknik servisimize danışılması gerekir.

- Hız artışı durumunda.
- Redüktör arızasında canlılara zarar verebileceği uygulamalar.
- Yüksek ataletli uygulamalar.
- Kaldırma vinci olarak kullanım.
- Redüktörde yüksek dinamik gerilmelere sebep olabilecek uygulamalar.
- -5°C altında veya 40°C üzerindeki iş ortamında yapılan uygulamalar.
- Kimyasal aşındırıcı çevrelerde kullanım.
- Tuzlu ortamlarda kullanım.
- Katalogta belirtilmeyen montaj pozisyonlarında kullanım.
- Radyoaktif ortamlarda kullanım.
- Atmosferik basınçtan farklı basınç tiplerinin bulunduğu ortamlarda kullanım.
- Redüktör ünitesinin batırılması gerektiği uygulama ortamlarından sakının.

Redüktörün dayanabileceği maksimum tork değeri; (\*) Performans tablolarında belirtilen nominal tork değerinin ( $f_b = 1$ ) iki katı bir değeri aşmamalıdır. (\*) Maksimum kapasiteli yük değerleri ile yapılan başlatmalarda, frenlemelerde, özellikle dinamik olan şok ve diğer nedenlerde, momente bağlı aşırı yüklerde geçerlidir.

## EN CRITICAL APPLICATIONS

The performance given in the catalogue correspond to mounting position B3 or similar, ie. when the first stage is not entirely immersed in oil. For other mounting positions and/or particular input speeds, refer to the tables that highlight different critical situations for each size of reduction unit.

It is also necessary to take due consideration of and carefully assess the following applications by calling our Technical Service:

- As a speed increasing.
- Use in services that could be hazardous for people if the reduction unit fails.
- Applications with especially high inertia.
- Use as a lifting winch.
- Applications with high dynamic strain on the case of the reduction unit.
- In places with  $T^\circ$  under  $-5^\circ\text{C}$  or over  $40^\circ\text{C}$ .
- Use in chemically aggressive environments.
- Use in a salty environment.
- Mounting positions not envisaged in the catalogue.
- Use in radioactive environments.
- Use in environments pressures other than atmospheric pressure.
- Avoid applications where even partial immersion of the reduction unit is required.

The maximum torque; (\*) that the gear reducer can support must not exceed two times the nominal torque ( $f_b = 1$ ) stated in the performance tables. (\*) intended for momentary overloads due to starting at full load, braking, shocks or other causes, particularly those that are dynamic.

## DE KRISTISCHE ANWENDUNGEN

Die im Katalog aufgeführten Leistungsdaten gelten für die Einbaulage B3 oder gleichwertig, wenn das Ritzel nicht völlig mit Öl geschmiert wird.

Für andere Einbaulagen und / oder besondere Antriebsdrehzahlen sind die Tafeln zu beachten, die verschiedene kritische Zustände für jede Getriebegröße darstellen. Darüber hinaus sind nachstehende Anwendungen zu beachten und eventuell sollte mit unserem Kundendienst Kontakt aufgenommen werden:

- Einsatz als Übersetzungsgetriebe (Übersetzung ins Schnelle).
- Anwendungen, die bei Bruch des Getriebes für den Menschen gefährlich sein könnten.
- Anwendungen mit sehr hohen Trägheitsmomenten.
- Einsatz als Hebewinde.
- Anwendungen mit hohen dynamischen Beanspruchungen auf Getriebegehäuse.
- Einsatz bei Umgebungstemperaturen unter  $-5^\circ\text{C}$  oder über  $40^\circ\text{C}$ .
- Einsatz in Verbindung mit aggressiven chemischen Substanzen.
- Einsatz unter Salzwassereinwirkung.
- Nicht im Katalog vorgesehene Einbaulagen.
- Einsatz unter radioaktiver Strahlung.
- Einsatz unter einem Druck, der nicht dem normalem Luftdruck entspricht.

Anwendungen, bei denen das Eintauchen des Getriebes in Wasser vorgesehen ist (auf teilweise), sollen vermieden werden. Das max. zulässige Drehmoment; (\*) des Getriebes, darf nicht den zweifachen Wert des in der Leistungstabelle angegebenen nominalen Wert des Drehmomentes ( $f_b = 1$ ) übersteigen.

(\*) Hierbei sind Überlasten gemeint, welche durch Anlaufen unter Vollast, Bremsungen, Stöße und weiter dynamische Ursachen, hervorgerufen werden.B

PMRV	030	040	050	063	075	090	105	110	130	150
V5: $1500 < n1 < 3000$	-	-	-	-	B	B	B	B	B	B
$n1 > 3000$	B	B	B	B	A	A	A	A	A	A
V6	B	B	B	B	B	B	B	B	B	B

**A** Uygulama yapılması tavsiye edilmez  
Application not recommended  
Nicht empfohlene Anwendung

**B** Yapılan uygulamayı kontrol edin ve/veya Teknik Servisimize durumu bildirin.  
Check the application and/or call our technical service.  
Anwendung überprüfen und/oder mit unserem Kundendienst Kontakt aufnehmen.

**IT** APLICAZIONI CRITICHE

Le prestazioni indicate a catalogo corrispondono alla posizione B3 o similari, quando cioè il primo stadio non è interamente immerso in olio. Per situazioni di pizamento diverse e/o velocità di ingresso particolari attenersi alle tabelle che evidenziano situazioni critiche diverse per ciascuna taglia di riduttore.

Occorre anche tenere nella giusta considerazione e valutare attentamente le seguenti applicazioni consultando il ns. ServizioTecnico:

- Utilizzo come moltiplicatore.
- Utilizzo in servizi che potrebbero risultare pericolosi per l'uomo in caso di rottura del riduttore.
- Applicazioni con inerzie particolarmente elevate.
- Utilizzo come argano di sollevamento.
- Applicazioni con elevate sollecitazioni dinamiche sulla cassa del riduttore.
- Utilizzo in ambiente con T° inferiore a -5°C o superiore a 40°C.
- Utilizzo in ambiente con presenza di aggressivi chimici.
- Utilizzo in ambiente salmastro.
- Posizioni di piazzamento non previste a catalogo.
- Utilizzo in ambiente radioattivo.
- Utilizzo in ambiente con pressione diversa da quella atmosferica.

Evitare applicazioni dove è prevista l'immersione, anche parziale, del riduttore.

La coppia massima (\*) sopportabile dal riduttore non deve superare il doppio della coppia nominale (fb=1) riportata nelle tabelle delle prestazioni. (\*) intesa come sovraccarico istantaneo dovuto a avviamenti a pieno carico, frenature, urti ed altre cause soprattutto dinamiche.

**FR** APPLICATIONS CRITIQUES

Les performances indiquées sur le catalogue correspondent à la position B3 ou similaires, lorsque le premier train d'engrenage n'est pas entièrement immergé dans l'huile.

Pour les combinaisons d'assemblage différentes et/ou les vitesses d'entrée particulières, se conformer aux tableaux qui mettent en évidence les différentes situations critiques pour chaque taille de réducteur.

Il faut aussi prendre en considération et évaluer attentivement les applications suivantes, en consultant notre S.ce Technique:

- Emploi comme multiplicateur.
- Emploi en services qui pourraient être dangereux pour l'homme en cas de rupture du réducteur.
- Applications avec inerties particulièrement élevées.
- Emploi comme treuil, en cas de soulèvement.
- Applications avec sollicitations dynamiques sur la carcasse du réducteur.
- Emploi en milieu avec température au - dessous de -5°C ou au-dessus de 40°C.
- Emploi en milieu en présence d'agents chimiques agressifs.
- Emploi en milieu saumâtre.
- Positions de montage non prévues sur le catalogue.
- Emploi en milieu radioactif.
- Emploi en milieu ayant une pression différente de celle atmosphérique.

Eviter les applications dans lesquelles l'immersion du réducteur, même si partielle, est prévue.

Le couple maximum (\*) supporté par le réducteur ne doit pas être supérieur au double du couple nominal (fb =1) suivant notre table de prestation. (\*) Entendu comme surcouple instantané dû à démarrages en pleine charge, freinages, chocs et autres causes surtout dynamiques.

**ES** APLICACIONES CRITICAS

Las prestaciones indicadas en el catálogo corresponden a la posición B3 o similares, cuando el primer tren de engranajes no está completamente inmerso en el aceite. Para posiciones de montaje distintas y/o de velocidades particulares a la entrada, atenderse a las tablas que ponen en evidencia las distintas situaciones críticas por cada tamaño de reductor.

Además es necesario considerar y evaluar cuidadosamente las siguientes aplicaciones, poniéndose en contacto con nuestro Servicio técnico:

- Utilización como multiplicador.
- Utilización en servicios que, en caso de ruptura del reductor, podrían resultar peligrosos para el hombre.
- Aplicaciones con inercias particularmente elevadas.
- Utilización como cabrestante de levantamiento.
- Aplicaciones con esfuerzos dinámicos elevados sobre la carcasa del reductor.
- Utilización en ambiente con T° inferior a -5°C o superior a 40°C.
- Utilización en ambiente con presencia de agentes químicos agresivos.
- Utilización en ambiente salino.
- Posiciones en montaje no previstas en el catálogo.
- Utilización en ambiente radioactivo.
- Utilización en ambiente con presión distinta de la atmosférica.

Evitar aplicaciones donde es prevista la inmersión, aún parcial, del reductor.

El par maximo (\*) soportable por el reductor no debe superar el doble del par nominal (fb=1) indicado en la tabla de prestaciones. (\*) Entendida como sobrecarga instantanea debida a puestas en marcha a plena carga, frenados, impactos y otras causas sobretodo dinamicas.

PMRV	030	040	050	063	075	090	105	110	130	150
V5: 1500 < n1 < 3000	-	-	-	-	B	B	B	B	B	B
n1 > 3000	B	B	B	B	A	A	A	A	A	A
V6	B	B	B	B	B	B	B	B	B	B

**A** Applicazione sconsigliata  
Application non conseillée  
Aplicación desaconsejada

**B** Verificare l'applicazione e/o contattare il ns. servizio tecnico.  
Verifier l'application et/ou contacter notre s.ce technique.  
Controlar la aplicación y/o ponerse en contacto con nuestro servicio técnico.

**TR MONTAJ**

Redüktörü monte etmek için aşağıdaki verilen tavsiyeleri uygulamanız gerekmektedir.

- Yapılacak olan montaj işleminde makinede olabilecek bir titreşimi engellemek için sabit olmalıdır.
- Cihazı makineye monte etmeden önce redüktör çıkış şaftının dönme yönünün doğru olup olmadığını kontrol edin.
- Belirgin düzeyde uzun süreli olarak yapılacak depolama işlemlerinde (4/6 ay) şayet yağ keçesi redüktör içindeki yağa batık konumda değilse kauçuk parçanın şafta yapışma riski bulunduğundan veya doğru olarak çalışmasını engelleyebilecek şekilde elastikliğini kaybetme riski bulunduğundan parçanın değiştirilmesini tavsiye ederiz.
- Delik milli redüktörlerin şaft montaj işlemi için Polat'ın tedarik edeceği tork kollarını kullanınız. Eğer bunu kullanmak mümkün değilse zorlamanın aksi olarak serbest olduğundan ve redüktörü serbest hareket imkanı tanıdığından emin olun.
- Mümkün olduğunca redüktörü güneş ışınlarından kaynaklanan radyasyondan ve kötü hava koşullarından koruyunuz.
- Fan kısmından iyi bir hava akışı sağlanarak motor soğutmasının uygun bir şekilde yapıldığından emin olun.
- <-5 C° veya > +40 C° gibi aşırı ısı değerlerinin bulunduğu ortamda Teknik Servise başvurunuz.
- Değişik parçalar (makaralar, şanzuman, kaplin, şaft vb.) özel olarak açılmış kilavuzlar kullanılarak rulman yatağı veya dış parçalarına zarar vermeyecek şekilde tasarlanmış sistemler kullanmak suretiyle hasar riski olmadan mil yada delik milli üzerine monte edilmelidir. Birbirleriyle temas eden yüzeyleri aşınma veya paslanma riskine karşı yağlayınız.
- Yapılacak boyama işlemi kesinlikle keçe (kauçuk) parçalarının alt kısımlarına nüfuz edecek şekilde veya varsa havalandırma deliklerini kapatacak şekilde olmamalıdır.
- Yağ tapası gönderilen redüktörlerin seviyesi için kullanılan kör tapa özel havalandırma tapası ile değiştirilmelidir.
- Mümkünse yağ seviyesini indikatörle kontrol ediniz.
- Başlatma işi kademeli olarak maksimum güç yüklemesine hemen geçilmeden yapılmalıdır.
- Sınırlı düzeyde bile olsa yağ sızıntısı ile hasara uğrayabilecek motor altında parçalar, nesnelere veya malzemeler olması halinde bu durum için özel koruma takılmalıdır.

**EN INSTALLATION**

To install the reduction unit it is necessary to note the following Recommendations:

- The mounting on the machine must be stable to avoid any vibration
- Check the correct direction of rotation of the gear reducer output shaft before fitting the unit to the machine.
- In the case of particularly lengthy periods of storage (4/6 months), if the oil seal is not immersed in the lubricant inside the unit, it is recommended to change it since the rubber could stick to the shaft or may even have lost the elasticity it needs to function properly.
- For a shaft mounting, for reduction units with a hollow output shaft, use the torque arms Polat can supply. If this is not possible, make sure that the constraint is axially free and with such play as to ensure free movement for the reduction unit.
- Whenever possible, protect the reduction unit against solar radiation and bad weather.
- Ensure the motor cools correctly by assuring good passage of air from the fan side.
- In the case of ambient temperatures < -5°C or > +40°C call the Technical Service.
- The various parts (pulleys, gear wheels, couplings, shafts, etc.) must be mounted on the solid or hollow shafts using special threaded holes or other systems that anyhow ensure correct operation without risking damage to the bearings or external parts of the units. Lubricate the surfaces in contact to avoid seizure or oxidation.
- Painting must definitely not go over rubber parts and the holes on the breather plugs, if any.
- For units equipped with oil plugs, replace the closed plug used for shipping with the special breather plug.
- Check the correct level of the lubricant through the indicator, if there is one.
- Starting must take place gradually, without immediately applying the maximum load.
- When there are parts, objects or materials under the motor drive that can be damaged by even limited spillage of oil, special protection should be fitted.

**DE MONTAGE**

Für die Montage des Getriebes sind nachstehende Anweisungen zu beachten:

- Die Befestigung an der Maschine muß absolut stabil sein, um jegliche Vibrationen zu vermeiden.
- Vor der Montage des Getriebes an der Maschine ist die Abtriebswelle des Getriebes auf die richtige Drehrichtung zu prüfen.
- Nach besonders langer Einlagerung (4/6 Monate) ist zu überprüfen, ob die Wellendichtringe vom Schmiermittel des Getriebes vollständig benetzt wurden; andernfalls ist ein Austausch anzuraten, da die Dichtlippe auf der Welle festkleben kann oder die zum einwandfreien Betrieb notwendige Elastizität nicht mehr vorhanden ist.
- Bei Pendelbefestigung für Getriebe mit Abtriebshohlwelle sind die von Polat gelieferten Drehmomentstützen zu verwenden; als Alternative muß kundenseitig eine geeignete Drehmomentabstützung erfolgen, wobei hierdurch weder axiale noch Kippmomentbelastungen auf die Lager erzeugt werden dürfen.
- Wenn möglich, sollte das Getriebe vor Sonneneinstrahlung u.a. Witterungseinflüssen geschützt werden.
- Die Motorkühlung muß durch eine gute Belüftung auf der Seite des Lüfters gewährleistet werden.
- Bei Umgebungstemperaturen < -5°C oder > +40°C setzen Sie sich bitte mit dem Kundendienst in Verbindung.
- Zur Montage der unterschiedlichen Anbauteile (Riemenscheiben, Zahnräder, Kupplungen, Wellen usw.) auf den Hohl- oder Vollwellen sind die vorgesehenen Gewindebohrungen oder Aufziehvorrichtungen zu verwenden. Diese gewährleisten eine einwandfreie Montage, ohne die Lager oder die Außenteile des Getriebes zu beschädigen. Die in Berührung kommenden Passungen und Oberflächen der Wellen sind zu fetten/ölen, um ein Festfressen durch Passungsrost zu vermeiden.
- Bei Lackierung ist darauf zu achten, daß alle Gummitteile und fallweise die in den Entlüftungsdeckeln vorhandenen Bohrungen nicht überlackiert werden.
- Bei Getrieben mit Ölstopfen ist die zum Transport verwendete Verschlussschraube durch die beigelegte Entlüftungsschraube zu ersetzen.
- Der Schmierölstand ist an der Füllstandsanzeige zu überprüfen, sofern vorhanden.
- Der Antrieb ist stufenweise in Betrieb zu nehmen, wobei zunächst mit Teillast angefahren werden sollte.
- Sind unter dem Antrieb Geräteteile oder Materialien angeordnet, die durch geringe Mengen austretenden Öls beschädigt werden könnten, so ist eine geeignete Schutzvorrichtung vorzusehen.

IT

## INSTALLAZIONE

Per l'installazione del riduttore è consigliabile attenersi alle seguenti indicazioni:

- Il fissaggio sulla macchina deve essere stabile per evitare qualsiasi vibrazione.
- Verificare il corretto senso di rotazione dell'albero di uscita del riduttore prima del montaggio del gruppo sulla macchina.
- In caso di periodi particolarmente lunghi di stoccaggio (4/6 mesi) se l'anello di tenuta non è immerso nel lubrificante contenuto all'interno del gruppo si consiglia la sua sostituzione in quanto la gomma potrebbe essersi incollata all'albero o addirittura aver perso quelle caratteristiche di elasticità necessarie al corretto funzionamento.
- Nel fissaggio pendolare, per riduttori ad albero di uscita cavo, adottare i bracci di reazione fornibili da Polat, se questo non è possibile assicurarsi che il vincolo sia libero assialmente e con giochi tali da garantire la libera oscillazione del riduttore.
- Quando possibile proteggere il riduttore dall'irraggiamento solare e dalle intemperie.
- Garantire un corretto raffreddamento del motore assicurando un buon passaggio d'aria dal lato ventola.
- Nel caso di temperature ambiente < -5°C o > +40°C contattare il servizio Assistenza Tecnica.
- Il montaggio dei vari organi (pulegge, ruote, dentate, giunti, alberi, ecc.) sugli alberi pieni o cavi deve essere eseguito utilizzando appositi fori filettati o altri sistemi che comunque garantiscano una corretta operazione senza rischiare il danneggiamento dei cuscinetti o delle parti esterne dei gruppi. Lubrificare le superfici a contatto per evitare grippaggi o ossidazioni.
- La verniciatura non deve assolutamente interessare le parti in gomma e i fori esistenti sui tappi di sfianto, quando presenti.
- Per i gruppi provvisti di tappi per olio sostituire il tappo chiuso utilizzato per la spedizione con l'apposito tappo di sfianto.
- Controllare il corretto livello del lubrificante tramite, quando prevista l'apposita spia.
- La messa in funzione deve avvenire in maniera graduale, evitando l'applicazione immediata del carico massimo.
- Quando sotto alla motorizzazione sono presenti organi, cose o materiali danneggiabili dall'eventuale fuoriuscita, anche limitata, di olio è opportuno prevedere un'apposita protezione.

FR

## INSTALLATION

Pour l'installation du réducteur, il faut se conformer aux indications suivantes:

- La fixation sur la machine doit être stable pour éviter toute vibration.
- Avant le montage du groupe sur la machine, vérifier que le sens de rotation de l'arbre de sortie du réducteur soit correct.
- En cas de périodes de stockage particulièrement longues (4/6 mois), si la bague d'étanchéité n'est pas immergée dans le lubrifiant contenu à l'intérieur du groupe, on conseille son remplacement, car le caoutchouc pourrait être collé à l'arbre ou avoir perdu les caractéristiques d'élasticité nécessaires à un fonctionnement correct.
- En cas de fixation pendulaire, adopter, pour les réducteurs à arbre de sortie creux, les bras de réaction livrés par Polat; au cas où ceci ne soit pas possible, vérifier que la limitation soit axialement libre et ait des jeux pouvant assurer la libre oscillation du réducteur.
- Si possible, protéger le réducteur des rayons du soleil et des intempéries.
- Vérifier que le refroidissement du moteur soit suffisant, en assurant un bon passage d'air du côté ventilateur.
- En cas de températures ambiante < -5°C ou > +40°C, contacter le Service techniques.
- Le montage de différents organes (poules, roues dentées, accouplements, arbres, etc.) sur les arbres pleins ou creux doit être effectué en utilisant les trous filetés ou d'autres systèmes assurant de toute façon une opération correcte, sans risquer d'endommager les roulements ou les parties extérieures des groupes. Lubrifier les surfaces en contact, afin d'éviter le grippage ou l'oxydation.
- La peinture ne doit absolument pas toucher les parties en caoutchouc et, si présents, les trous sur les bouchons d'évent.
- Pour les groupes avec bouchons d'huile, remplacer le bouchon, utilisé lors de l'expédition, par le bouchon d'évent.
- Contrôler, grâce au voyant (si prévu), que le niveau du lubrifiant correspond.
- La mise en marche doit s'effectuer d'une façon graduelle, en évitant l'application immédiate de la charge maximale.
- Si des organes, des choses ou des matériels pouvant être endommagés par l'éventuelle sortie d'huile, même si limitée, sont présents sous la motorisation, il faut prévoir une protection adéquate.

ES

## INSTALACIÓN

Para la instalación del reductor, atenerse a las siguientes indicaciones:

- Para evitar las vibraciones, la fijación sobre la máquina tiene que ser estable.
- Antes del montaje del grupo sobre la máquina, controlar que el sentido de rotación del eje de salida del reductor sea correcto.
- En caso de periodos de almacenamiento muy largos (4/6 meses), si el retén no está sumergido en el lubricante contenido en el grupo, se aconseja su reemplazo porque la goma podría estar pegada al eje o haber perdido las características de elasticidad necesarias para un funcionamiento correcto.
- En la fijación pendular, adoptar, para reductores de eje de salida hueco, los brazos de reacción entregados por Polat; si no es posible, asegurarse que la limitación esté axialmente libre y con juegos que puedan garantizar la libre oscilación del reductor.
- Siempre que sea posible, proteger el reductor contra los rayos del sol y la intemperie.
- Controlar que la refrigeración del motor sea suficiente, asegurando una correcta transferencia de aire del lado ventilador.
- En caso de temperatura ambiente de < -5°C o > +40°C, ponerse en contacto con el Servicio técnico.
- El montaje de distintos órganos (poleas, ruedas dentadas, acoplamientos, ejes, etc.) sobre los ejes llenos o huecos debe ser efectuado utilizando los agujeros roscados correspondientes u otros sistemas, asegurando de todas maneras una operación correcta sin correr el riesgo de dañar los cojinetes o las partes externas de los grupos. Lubricar las superficies en contacto para evitar los grippados o las oxidaciones.
- El barnizado no debe cubrir las partes de goma y los agujeros de los posibles tapones-respiraderos.
- Para los grupos equipados de tapones de aceite, reemplazar el tapón cerrado, utilizado durante el transporte, por el tapón respiradero.
- Controlar el correcto nivel de lubricante mediante la mirilla (si la hay).
- La puesta en marcha se debe producir de manera gradual evitando la aplicación súbita de la carga máxima.
- Si bajo el reductor hay mecanismos, cosas ó materiales que puedan dañarse por una eventual pérdida de aceite, deberá preverse una protección adecuada.

**TR PAM-IEC B5 FLANŞI İLE MOTOR MONTAJI**

Redüktör motorsuz olarak tedarik edildiğinde elektrik motorunun doğru olarak montaj edildiğinden emin olmak için aşağıdaki tavsiyelere uyulmak zorundadır. Akuplajlı bir PAM flanş ile flanş montajlı motorların şanzıman kısmına takılması;

Motor şaftı ve flanş toleranslarının standartla uygun olup olmadığını kontrol edin. Dikkatlice şaftı, tapayı ve flanş yüzeylerini, boyadan arta kalan parçacıkları ve tozları temizleyip, kamanın doğru olarak yerleştirilip yerleştirilmediğini teyit edin. Flanş montajlı motorun Pam flanşlı redüktöre montajında kaplin kullanılır.

Gerekli montaj ekipmanı kullanıp motor milinin ve rulmanları zedelenmesinin önlenmesi sağlanarak motor şaftına kaplin montaj edilir.

Kaplinin elastik elemanı motor milinde bulunan yarım kapline yerleştirilir ve motor dikey pozisyonda yarım kaplinli, sürücü çevirilerek kaplin elemanı hizalanır. Kama kanalları toleransla montajlanmalıdır.

**EN MOTOR MOUNTING WITH PAM-IEC FLANGE B5**

When the unit is supplied without motor, it is necessary to follow these recommendation to ensure the correct assembly of the electric motor. Assembly of flange mounting motors to the gear unit with the PAM flange uses a coupling.

Check that the tolerances for the motor shaft and flange correspond to the standard. Carefully clean the shaft, spigot and surfaces of the flange removing traces of paint and dirt, and confirm the key is fitted correctly.

Fit the half coupling to the motor shaft (see picture) taking care to ensure the motor shaft and bearings are not damaged by avoiding excessive force and where necessary using assembly equipment.

Place the couplings elastic element onto the motor half coupling and position the motor up to the gear unit ensuring the coupling element is aligned with the driven half coupling. Complete the assembly using the fixing bolts. Key-ways with tightened tolerances.

**DE MONTAGE DES MOTORS AN DEN PAM-IEC FLANSCH B5**

Bei Getrieben, welche ohne motor geliefert werden, sind folgende Vorsichtsmaßnahmen zu beachten, um eine korrekte Montage des Elektromotors zu gewährleisten.

Übereinstimmung der Toleranzen von Welle und Motorflansch überprüfen.

Diese sollten mindestens DIN 42955 N entsprechen. Welle, Passung und Flanschfläche sind sorgfältig von Schmutz, Späne oder Lackresten zu säubern.

Halbkupplung auf Motor (sehen Bild) einsetzen, andernfalls sind die korrekte Ausrichtung und die Toleranz der Paßfeder zu überprüfen. In jedem Fall sind solche Montageverfahren anzuwenden, die Schäden an den Motorlagern ausschließen.

Motor anbauen, wobei es zuerst darauf beachtet werden muß, dass die Halbkupplung auf dem Motor und der elastische Zwischenring auf der Getriebelagerkupplung frei eingreifen können.

Keine Anpassung der Motorpaßfeder ist in diesem Fall erforderlich.

**IT MONTAGGIO MOTORE SU FLANGE PAM-IEC B5**

Quando il gruppo viene fornito senza motore occorre osservare le seguenti raccomandazioni per garantire un corretto montaggio del motore elettrico.

Controllare che le tolleranze dell'albero e della flangia motore siano corrispondenti almeno a una classe di qualità "normale". Pulire accuratamente l'albero, il centraggio ed il piano della flangia da sporco o tracce di vernice.

Procedere al montaggio del semigiunto (vedi figura) sull'albero del motore elettrico che deve avvenire senza eccessiva forzatura in caso diverso controllare la corretta posizione e la tolleranza della linguetta motore; utilizzare comunque opportuni sistemi che garantiscano un corretto montaggio senza rischiare il danneggiamento dei cuscinetti motore. Procedere quindi al montaggio del motore completo di semigiunto facendo i denti di trascinamento del semigiunto lato motore con quelli dell'elemento elastico presente sul semigiunto fisso lato riduttore.

Non è previsto nessun adattamento della linguetta motore.

**FR INSTALLATION MOTEUR SUR BRIDE PAM-IEC B5**

Quand le groupe est fourni sans moteur, observez les recommandations suivantes pour garantir un montage correct du moteur électrique.

Contrôler que les tolérances de l'arbre et de la bride du moteur correspondent au moins à une classe de qualité «normale».

Nettoyer soigneusement l'arbre, le centrage et le plan de la bride des traces de saleté et de peinture.

Procéder au montage de demi-accouplement sur l'arbre moteur électrique sans forcer (voir image), dans le cas contraire, vérifier la position correcte et la tolérance de la clavette du moteur.

Utiliser, toutefois, des systèmes appropriés qui garantissent un montage correct sans risquer de détériorer les roulements du moteur.

Procéder de la même façon pour le montage du moteur avec le demiaccouplement coté moteur avec de l'élément élastique du demiaccouplement coté réducteur. Rainures clavette moteur avec tolérances réduites.

**ES GUÍA PARA LA SELECCIÓN DEL PRODUCTO**

Si al equipo se suministra sin motor es preciso observar las siguientes recomendaciones para garantizar un correcto montaje del motor eléctrico.

Verificar que la tolerancia del eje y de la brida motor se correspondan al menos a una clase de calidad "normal".

Limpiar cuidadosamente el eje, el centrado y el plano de asiento de restos de barniz o suciedad.

Proceder al montaje del semiacoplamiento en el eje del motor eléctrico sin excesiva fuerza, si no entra con suavidad verificar la correcta tolerancia de la chaveta del motor (ver imagen), utilizar en cualquier caso métodos de montaje que no dañen los rodamientos del motor.

Proceder a continuación al montaje del motor con el semiacoplamiento en el reductor, evitando la interferencia de los dientes del acoplamiento.

No se prevé ninguna adaptación de la chaveta del motor.

**TR RADYAL YÜKLER**

Şaft üzerindeki radyal yük aşağıdaki formülle hesaplanır:

$$F_{Re} = \frac{2000 \cdot M \cdot fz}{D} \leq F_{R1} \text{ o } F_{R2}$$

- Fre** (N)  
Sonuç radyal yük  
**M** (Nm)  
Şaft üzerindeki tork  
**D** (mm)  
Şaft üzerine monte edilmiş transmisyon elemanın çapı  
**FR** (N)  
Uygulanan maksimum radyal yük değeri (ilgili tablolara bakınız)
- fz** = 1,1 Dişliler  
1,4 Dişli zinciri  
1,7 v-makarası  
2,5 Düz makara

Sonuç radyal yük şaftın merkez hattına uygulanmadığında aşağıdaki formülle etkin yükün hesaplanması gerekir:

$$F_{Re} \leq \frac{F_{R.a}}{(b+x)} \leq F_{R1max} \text{ o } F_{R2max}$$

a, b, x = sayfa 13, 14'deki tablolarda verilen değerler

**EN RADIAL LOADS**

The radial load on the shaft is calculated with the following formula:

$$F_{Re} = \frac{2000 \cdot M \cdot fz}{D} \leq F_{R1} \text{ o } F_{R2}$$

- Fre** (N)  
Resulting radial load  
**M** (Nm)  
Torque on the shaft  
**D** (mm)  
Diameter of the transmission member mounted on the shaft  
**FR** (N)  
Value of the maximum admitted radial load (see relative tables)
- fz** = 1,1 gear pinion  
1,4 chain wheel  
1,7 v-pulley  
2,5 flat pulley

When the resulting radial load is not applied on the centre line of the shaft it is necessary to calculate the effective load with the following formula:

$$F_{Re} \leq \frac{F_{R.a}}{(b+x)} \leq F_{R1max} \text{ o } F_{R2max}$$

a, b, x = values given in the tables on page 13,14.

**DE QUERBELASTUNGEN**

Die Querbelastrung (Querkraft) auf der Welle wird durch nachstehende Formel berechnet:

$$F_{Re} = \frac{2000 \cdot M \cdot fz}{D} \leq F_{R1} \text{ o } F_{R2}$$

- Fre** (N)  
Resultierende Querkraft  
**M** (Nm)  
Wellendrehmoment  
**D** (mm)  
Durchmesser des an der Welle montierten Antriebselements  
**FR** (N)  
Max. zul. Querkraft (siehe entspr. Tafel)
- fz** = 1,1 Zahnrad  
1,4 Rad für Kette  
1,7 Flanschscheibe  
2,5 Flachriemenscheibe

Wenn die Querkraft nicht auf die Mitte der Welle bezogen ist, ist die effektive Kraft durch nachstehende Formel zu berechnen:

$$F_{Re} \leq \frac{F_{R.a}}{(b+x)} \leq F_{R1max} \text{ o } F_{R2max}$$

a, b, x = siehe Tafeln auf seite 13,14.

**IT CARICHI RADIALI**

Il carico radiale sull'albero si calcola con la seguente formula:

$$F_{Re} = \frac{2000 \cdot M \cdot fz}{D} \leq F_{R1} \text{ o } F_{R2}$$

- Fre** (N)  
Carico radiale risultante  
**M** (Nm)  
Momento torcente sull'albero  
**D** (mm)  
Diametro dell'elemento di trasmissione montato sull'albero  
**FR** (N)  
Valore di carico radiale massimo ammesso FR1-FR2 (ved. tab. relative)
- fz** = 1,1 Pignone dentato  
1,4 Ruota per catena  
1,7 Puleggia a gola  
2,5 Puleggia piana

Quando il carico radiale risultante è applicato in mezzzeria dell'albero occorre correggere il carico radiale ammissibile FR1-2 con la seguente formula:

$$F_{Re} \leq \frac{F_{R.a}}{(b+x)} \leq F_{R1max} \text{ o } F_{R2max}$$

a, b, x = Valori riportati nelle tabelle pag. 13,14.

**FR CHARGES RADIALES**

La charge radiale sur l'arbre doit être calculée selon la formule suivante:

$$F_{Re} = \frac{2000 \cdot M \cdot fz}{D} \leq F_{R1} \text{ o } F_{R2}$$

- Fre** (N)  
Charge radiale résultante  
**M** (Nm)  
Moment de torsion sur l'arbre  
**D** (mm)  
Diamètre de l'élément de transmission monté sur l'arbre  
**FR** (N)  
Valeur de charge radiale maximum admise (voir tableaux correspondants)
- fz** = 1,1 pignon denté  
1,4 roue pour chaîne  
1,7 pouille à gorge  
2,5 pouille plate

Lorsque la charge radiale résultante n'est pas appliquée sur la ligne médiane de l'arbre, il faut alculer celle effective selon la formule suivante:

$$F_{Re} \leq \frac{F_{R.a}}{(b+x)} \leq F_{R1max} \text{ o } F_{R2max}$$

a, b, x = valeurs indiquées dans les tableaux à page 13,14

**ES CARGAS RADIALES**

La carga radial sobre el eje se calcula con la siguiente fórmula:

$$F_{Re} = \frac{2000 \cdot M \cdot fz}{D} \leq F_{R1} \text{ o } F_{R2}$$

- Fre** (N)  
Carga radial resultante  
**M** (Nm)  
Par de torsión sobre el eje  
**D** (mm)  
Diámetro del elemento de transmisión montado sobre el eje  
**FR** (N)  
Valor de carga radial máximo admitido ( ver tablas correspondientes)
- fz** = 1,1 Piñon dentado  
1,4 Piñon de cadena  
1,7 Polea para correa trapezoidal  
2,5 Polea plana

Si la carga radial resultante no está aplicada sobre la línea da centro del eje, es necesario calcular la efectiva con la siguiente fórmula:

$$F_{Re} \leq \frac{F_{R.a}}{(b+x)} \leq F_{R1max} \text{ o } F_{R2max}$$

a, b, x = valores indicados en las tablas pag.13,14

## TR RADYAL YÜKLER - TEKNİK TANIMLAR

Kabul edilebilir Radyal yük (N) değeri redüktörün performansını gösteren ilgili tablolarda verilmiştir. Bu şaftın merkez hattına binen yük ve en uygunsuz durumlarda uygulama açısı ve yönü ile ilgili bir olgudur.

Kombinasyonlu uygulamalarda max. müsaade edilen eksenel yük radyal yükün 1/5'i kadar olmalıdır.

Çıkış şaftları ile ilgili olarak hazırlanan tablolarda max. kabul edilebilir değerler verilmiştir.

Gövde mukavemeti ile ilgili olduğundan bu değer çok aşılmamalıdır. Bazı istisnai durumlarda katalogta verilen yük değerleri aşılabılır. Bu durumda Teknik Servisimiz uygulama ile ilgili detay sağlar; yükün yönü, şaft rotasyonun yönü, verilecek servisin tipi.

## EN RADIAL LOADS - TECHNICAL DESCRIPTIONS

The value of the admissible radial load (N) is given in the tables relating to the performance of the reduction unit at issue. It is related to the load applied on the centre line of the shaft and in the most unfavourable conditions of angle of application and direction of rotation.

The maximum admissible axial loads are 1/5 of the value of the given radial load when are applied in combination with the radial load.

The tables relating to the output shafts give the maximum admissible value.

This value must never be exceeded since it relates to the strength of the case.

Particular conditions of radial load higher than the limits of the catalogue may occur. In this case, call our Technical Service and provide details on the application: direction of the load, direction of rotation of the shaft, type of service.

## DE QUERBELASTUNGEN - TECHNISCHE BESCHREIBUNGEN

Der Wert der zulässigen Querbelastung (N) wird in den Tabellen über die Leistungen des betreffenden Getriebes aufgeführt und ist die Kraft, die auf die Mittellinie der Wellen unter ungünstigsten Bedingungen wie Anwendungswinkel und Drehrichtung einwirkt.

Die zulässigen Axialbelastungen betragen 1/5 der aufgeführten Querbelastungen, wenn diese gleichzeitig einwirken. Die Tabellen über die Abtriebswellen geben den für die Lager bzw. das Gehäuse zulässigen Höchstwert an; dieser Wert darf nie überschritten werden.

Falls die im Katalog aufgeführten Grenzwerte doch überschritten werden sollen, setzen Sie sich bitte mit unserem Kundendienst in Verbindung und nennen Sie ihm alle Anwendungsdaten wie Belastungsrichtung, Drehrichtung der Welle, Anwendungstart.

## IT CARICHI RADIALI - DESCRIZIONI TECNICHE

Il valore del carico radiale (N) ammissibile viene riportato nelle tabelle relative alle prestazioni del riduttore in esame, ed è relativo al carico applicato sulla mezzeria dell'albero e nelle condizioni più sfavorevoli come angolo di applicazione e senso di rotazione. I carichi assiali massimi ammissibili sono 1/5 del valore del carico radiale indicato quando sono applicati in combinazione col carico radiale stesso.

Nelle tabelle relative agli alberi di uscita viene indicato il valore massimo ammissibile, questo valore non deve mai essere superato in quanto è relativo alla resistenza della cassa. Possono essere verificate condizioni particolari di carico radiale superiori ai limiti di catalogo, in questo caso contattare il ns.

Servizio Tecnico e fornire tutti i dati applicativi: direzione del carico, senso di rotazione dell'albero, tipo di servizio.

## FR CHARGES RADIALES - DESCRIPTIONS TECHNIQUES

La valeur de la charge radiale (N) admissible est indiquée dans les tableaux concernant les performances du réducteur examiné et correspond à la charge appliquée sur la ligne médiane de l'arbre, dans les conditions les plus défavorables au niveau de l'angle d'application et du sens de rotation. Les charges axiales maximales admissibles sont 1/5 de la valeur de la charge radiale indiquée, au cas où elles seraient appliquées en combinaison avec la charge radiale même. Les tableaux concernant les arbres de sortie indiquent la valeur maximale admissible, valeur qui ne doit jamais être dépassée car elle correspond à la résistance de la carcasse. Des conditions particulières de charges radiales supérieures aux limites de catalogue peuvent être vérifiées; dans ce cas, contacter notre S.ce Technique en donnant toutes les données d'application: direction de la charge, sens de rotation de l'arbre, type de service.

## ES CARGAS RADIALES - DESCRIPCIONES TÉCNICAS

El valor de carga radial (N) admisible es las indicado en las tablas relacionadas a las prestaciones del reductor examinado y se refiere a la carga aplicada sobre la línea de centro del eje y en las condiciones más desfavorables como ángulo de aplicación y sentido de rotación. Las cargas axiales máximas admisibles son 1/5 del valor de carga radial indicado, cuando están aplicadas en combinación con la carga radial misma. En las tablas relacionadas a los ejes de salida se indica el valor máximo admisible; nunca se debe superar este valor, porque se refiere a la resistencia de la carcasa. Podrían presentarse condiciones particulares de carga radial superiores a los límites de catálogo; en este caso, ponerse en contacto con nuestro Servicio técnico e indicar todos los datos de la aplicación: dirección de carga, sentido de rotación del eje, tipo de servicio.



TR RADYAL YÜKLER  
IT CARICHI RADIALI

EN RADIAL LOADS  
FR CHARGES RADIALES

DE QUERBELASTUNGEN  
ES CARGAS RADIALES

ÇIKIŞ ŞAFTI - OUTPUT SHAFTS - ABTRIEBSWELLEN - ALBERI IN USCITA - ARBRES DE SORTIE - EJES DE SALIDA

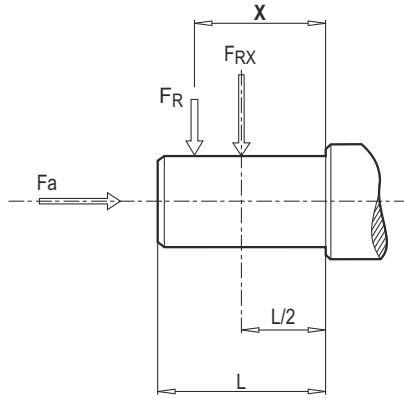

PMRV	030	040	050	063	075	090	105	110	130	150
a	65	84	101	120	131	162	176	176	188	215
b	50	64	76	95	101	122	136	136	148	174
<b>FR max</b>	1830	3490	4840	6270	7380	8180	12000	12000	13500	18000

- (\*) Tek yönlü maksimum aksel yük değerleri bir basma yatağı kullanılarak (talebe bağlı) kabul edilebilir.  
 (\*) Maximum axial load values admissible in only one direction with the use of a thrust bearing (on request).  
 (\*) Die Werte der maximal zulässigen Axialkräfte beziehen sich auf eine Drehrichtung bei verbautem Axiallager (auf Anfrage).  
 (\*) Valori di carico assiale massimo ammissibile in una sola direzione per versione con cuscinetto reggispinga (a richiesta).  
 (\*) Valeurs de charge axiale maximum admissible dans une seule direction pour la version avec roulements coniques (sur demande).  
 (\*) Valores de la fuerza axial maxima admissible en un unico sentido con rodamiento axial (bajo demanda).

Kabul edilebilir radyal yük değerleri performansla ilgili sayfalarda verilmiştir. (FR)  
 The values of the admissible radial loads are given on the pages relating to performance. (FR)  
 Die Werte der zulässigen Querbelastrungen sind in den Seiten über die Leistungen (FR) aufgeführt.  
 Accettabili valori di carico radiale sono dati relativi alle prestazioni pagine.(FR)  
 Les valeurs des charges radiales admissibles sont indiquées dans les pages concernant les performances (FR)  
 Los valores de cargas radiales admisibles son indicados en las páginas sobre las prestaciones (FR)

TR RADYAL YÜKLER

EN RADIAL LOADS

DE QUERBELASTUNGEN

IT CARICHI RADIALI

FR CHARGES RADIALES

ES CARGAS RADIALES

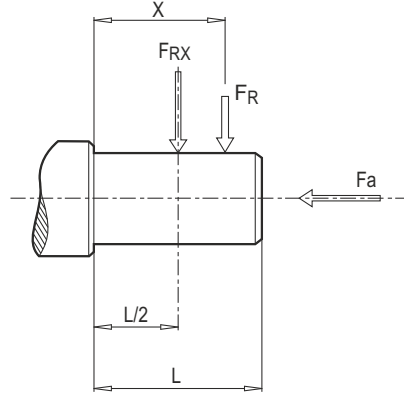
**GİRİŞ ŞAFTI - INPUT SHAFTS - ANTRIEBSWELLEN - ALBERI IN ENTRATA - ARBRES D'ENTREE - EJES DE ENTRADA**

PRV	030	040	050	063	075	090	105	110	130	150
<b>a</b>	86	106	129	159	192	227	266	266	314	350
<b>b</b>	76	94,5	114	139	167	202	236	236	274	310
<b>FR max</b>	210	350	490	700	980	1270	1700	1700	2100	2800

Kabul edilebilir yük değerleri performansla ilgili sayfalarda verilmiştir ( $F_R$ ).

The values of the admissible radial loads are given on the pages relating to performance ( $F_R$ ).

Die Wertw der zulässigen Querbelastrungen sind in den Seiten über die Leistungen ( $F_R$ ) aufgeführt.

Accettabili valori di carico radiale sono dati relativi alle prestazioni pagine ( $F_R$ ).

Les valeurs des charges radiales admissibles sont indiquées dans les pages concernant les performances ( $F_R$ ).

Los valores de cargas radiales admisibles son indicados en las páginas sobre las prestaciones ( $F_R$ ).

TR

## YAĞLAMA

Tabloda belirtilmeyen aşırı ısı ortamlarında Teknik Servisimizi arayınız.

30 C° altındaki bir ısı değerinde veya 60 C° üzerindeki bir ısı değerinde hassas özelliklere sahip yağ keçesi kullanmak gerekir.

0 C°'nin altındaki sıcaklık değerlerinde çalışmak gerekiyor- sa aşağıdakileri göz önünde tutmak gerekir:

- 1- Motorlar tahmin edilen ortam sıcaklıklarındaki operasyonlara uygunluk gerektirir.
- 2- Elektrik motorunun gücü gerekli olan yüksek başlama tork değerlerini aşabilmesi için yeterli olmalıdır.
- 3- Redüktörlerin dökme demirden imal edildiği durumlarda -15 C° sıcaklığın altında dökme demirin kırılma riski bulunduğu darbe yüklerine özen gösterin.
- 4- Servis hizmetinin ilk aşamalarında yağın sahip olduğu aşırı akışkanlık olayından dolayı birtakım yağlama problemleri meydana gelebilir, bu durumda yüksüz olarak birkaç dakika boyunca çalıştırmak gerekir.

Yağ değişimi yaklaşık 10.000 saatlik kullanımdan sonra yapılmalıdır. Bu süre servis tipine ve redüktörün çalıştığı ortama göre değişir. Yağ tapalarıyla birlikte verilmeyen redüktörler için, yağlama kalıcıdır ve bu nedenle servis gerektirmez.

EN

## LUBRICATION

In cases of ambient temperatures not envisaged in the table, call our Technical Service.

In the case of temperatures under -30°C or over 60°C it is necessary to use oil seals with special properties.

For operating ranges with temperatures under 0°C it is necessary to consider the following:

- 1- The motors need to be suitable for operation at the envisaged ambient temperature.
- 2- The power of the electric motor needs to be adequate for exceeding the higher starting torques required.
- 3- In case of cast - iron gear reducers, pay attention to impact loads since cast iron may have problems of fragility at temperatures under -15°C.
- 4- During the early stages of service, problems of lubrication may arise due to the high level of viscosity taken on by the oil and so it is wise to have a few minutes of rotation under no load.

The oil needs to be changed after approximately 10,000 hours. This period depends on the type of service and the environment where the reduction unit works. For unit supplied without oil plugs, lubrication is permanent and so they need no servicing.

DE

## SCHMIERUNG

Bei in der Tafel nicht vorgesehene Umgebungstemperaturen setzen Sie sich bitte mit unserem Kundendienst in Verbindung.

Bei Temperaturen unter -30°C oder über 60°C werden Dichtringe aus besonderen Elastomeren benötigt.

Bei Betrieb mit Temperaturen unter 0°C ist folgendes zu berücksichtigen:

- 1- Die Motoren müssen für den Betrieb mit der vorgesehenen niedrigen Raumtemperatur geeignet sein.
- 2- Die Leistung des Elektromotors muß so ausgelegt werden, daß die höheren benötigten Anlaufdrehmomente aufgebracht werden können.
- 3- Bei Getriebegehäusen aus Guß sind die Stoßbelastungen zu beachten, weil der Guß bei Temperaturen unter -15°C verpröden könnte.
- 4- Bei Betriebsbeginn könnten Schmierungsprobleme infolge der hohen Ölviskosität auftreten, daher ist es sinnvoll, für einige Minuten einen Leerlauf auszuführen.

Je nach Umgebungsbedingungen und Betriebsart ist nach etwa 10.000 Betriebsstunden ein Ölwechsel durchzuführen. Die Getriebe ohne Ölstopfen sind langzeitgeschmiert und benötigen daher keine weiteren Wartungsarbeiten.

IT

## LUBRIFICAZIONE

Nei casi con temperature ambiente non previste in tabella contattare il ns. Servizio Tecnico.

In caso di temperature inferiori a -30°C o superiori a 60°C occorre utilizzare anelli di tenuta con mescole speciali.

Per i campi di funzionamento con temperature inferiori a 0°C occorre considerare quanto segue:

- 1- I motori devono essere idonei al funzionamento con temperatura ambiente prevista.
- 2- La potenza del motore elettrico deve essere adeguata al superamento delle maggiori coppie di avviamento richieste.
- 3- Nel caso di riduttori con cassa in ghisa prestare attenzione ai carichi d'urto in quanto la ghisa può presentare problemi di fragilità a temperature inferiori ai -15°C.
- 4- Durante le prime fasi di servizio possono insorgere problemi di lubrificazione cause l'elevata viscosità che assume l'olio e quindi è opportuno procedere ad alcuni minuti di rotazione a "vuoto".

Il cambio olio deve essere eseguito dopo circa 10.000 ore, questo periodo è in funzione del tipo di servizio e dell'ambiente in cui opera il riduttore.

Per i gruppi forniti senza tappi per l'olio la lubrificazione si intende permanente e quindi non hanno necessità di alcuna manutenzione.

FR

## LUBRIFICATION

En cas de températures ambiantes non prévues dans le tableau, contacter notre S.ce Technique.

En cas de température au-dessous de -30°C ou au-dessus de 60°C, il faut utiliser des bagues d'étanchéité avec mélanges spéciaux.

Pour les champs de fonctionnement avec température au-dessus de 0°C, il faut considérer ce qui suit:

- 1- Les moteurs doivent être aptes au fonctionnement à la température ambiante prévue.
- 2- La puissance du moteur électrique doit être au dépassement de la plupart des couples de démarrage demandés.
- 3- En cas de réducteurs avec carcasse en fonte, faire attention aux charges de choc, car la fonte peut présenter des problèmes de fragilité à températures au-dessous de -15°C.
- 4- Lors des premières phases de service, des problèmes de lubrification dus à la viscosité élevée, que l'huile assume, pourraient se vérifier; il faut donc procéder à une rotation "à vide" de quelques minutes.

Le changement d'huile doit être effectué après 10,000 heures environ; cette période est en fonction du type de service et du milieu dans lequel le réducteur travaille. Pour les groupes livrés sans bouchons d'huile, la lubrification est permanente et ils ne nécessitent donc aucun entretien.

ES

## LUBRICACIÓN

En caso de temperaturas no previstas en la tabla, ponerse en contacto con nuestro Servicio técnico.

En caso de temperaturas inferiores a -30°C o superiores a 60°C, es necesario utilizar anillos de retén con mezclas especiales. Para los campos de funcionamiento con temperaturas inferiores a 0°C, es necesario cumplir con lo que sigue:

- 1- Los motores tienen que ser idóneos al funcionamiento con la temperatura ambiente prevista.
- 2- La potencia del motor eléctrico tiene que ser idónea para superar los mayores pares de arranque pedidos.
- 3- En caso de reductores con carcasa de fundición, cuidado con las cargas de choque porque la fundición puede presentar problemas de fragilidad con temperaturas inferiores a los -15°C.
- 4- Durante las primeras fases de servicio podrían surgir unos problemas de lubricación debidos a la elevada viscosidad del aceite y es por lo tanto oportuno efectuar una rotación en "vacío" por algunos minutos.

El cambio de aceite tiene que ser efectuado aproximadamente después de 10.000 horas; claramente, este periodo es en función del tipo de ambiente en el que trabaja el reductor. En los grupos entregados sin tapones, el lubricante es permanente y por lo tanto no necesitan ningún mantenimiento.

TR	YAĞLAMA
IT	LUBRIFICAZIONE

EN	LUBRICATION
FR	LUBRIFICATION

DE	SCHMIERUNG
ES	LUBRICACIÓN

		T°C ISO SAE...	AGIP	SHELL	ESSO	MOBIL	CASTROL	BP
PMRV 110 ... 150	Mineral Yağ Mineral Oil Mineralöl Olio Minerale Huile Minérale Aceite Mineral	(-5) / (+40) ISO VG460	BLASIA 460	OMALA OIL460	SPARTAN EP460	MOBILGEAR 634	ALPHA MAX 460	ENERGOL GR-XP460
		(-15) / (+25) ISO VG220	BLASIA 220	OMALA OIL220	SPARTAN EP220	MOBILGEAR 630	ALPHA MAX 220	ENERGOL GR-XP220
PMRV 030 ... 105 PPC 063 ... 090	Sentetik Yağ Synthetic Oil Synthetisches Öl Olio Sintetico Huile Synthétique Aceite Sintetico	(-25) / (+50) ISO VG320	TELIUM VSF320	TIVELA OIL SC320	S220	GLYGOYLE 30	ALPHASYN PG320	ENERGOL SG-XP320

TR	<b>Dikkat:</b> Dişli kutusu yağsızdır, çalıştırmadan önce seviyesine kadar doldurun.			
GB	<b>Attention:</b> Gearbox unit without lubricant, fill it up to the level before starting.			
D	<b>Achtung:</b> Getriebe ohne Schmierstoff, bitte vor Inbetriebnahme füllen.			
IT	<b>Attenzione:</b> Riduttore privo di lubrificante, riempire a livello prima dell'avviamento.			
FR	<b>Attention:</b> Groupe sans lubrifiant, remplir au niveau avant le démarrage.			
ES	<b>Atención:</b> Grupo sin lubricante, llenar hasta el nivel antes de la puesta en marcha.			
Mineral Yağ Mineral Oil Mineralöl Olio minerale Huile minérale Aceite mineral	<table border="1"> <tr> <td>T°C ISO VG...</td> <td>(-5) / (+40) ISO VG 220</td> <td>(-15) / (+25) ISO VG 150</td> </tr> </table>	T°C ISO VG...	(-5) / (+40) ISO VG 220	(-15) / (+25) ISO VG 150
T°C ISO VG...	(-5) / (+40) ISO VG 220	(-15) / (+25) ISO VG 150		

- Yağsız olarak tedarik edilen redüktör üzerlerinde bir uyarı etiketi taşır.
- The reduction units supplied without lubricant are provided with the relative warning-label.
- Die Getriebe welche ohne Schmiermittel ausgeliefert werden, sind durch ein entsprechendes Hinweisschild gekennzeichnet.
- I riduttori che vengono forniti privi di olio lubrificante sono contraddistinti dall'applicazione della relativa targhetta.
- Los reductores que se suministran sin lubricante son identificados mediante un tarjeta.
- Les réducteurs fournis sans lubrifiant sont signalés par un adhésif d'alerte.

- Yağ malzemesi ile ilgili özellikler Polat Group Redüktör A.Ş. tarafından tavsiye edilmektedir.
- Specifications of lubricants recommended by Polat Group Redüktör A.Ş.
- Spezifische Schmierstoffangabe erfragen Sie bei Polat Group Redüktör A.Ş.
- Specifiche dei lubrificanti consigliati da Polat Group Redüktör A.Ş.
- Especificaciones de lubricante aconsejados por Polat Group Redüktör A.Ş.
- Spécification des lubrifiants suivant Polat Group Redüktör A.Ş.

Yağ miktarı için ilgili sayfalara bakınız.  
 For the quantity of oil, please refer to the pages relating.  
 Für die Ölmenge siehe die Seiten.  
 Per le quantità di olio si rimanda alle pagine relative.  
 Pour les quantités d'huile, voir pages concernant.  
 Para las cantidades de aceite, ver a las páginas.

**TR** YAĞLAMA

- 030-040-050-060-075-090-105 Gövde büyüklüğündeki redüktörler ömür boyu yağlama gerektirmeyecek şekilde satılmaktadır, sentetik yağ, AGIP TELIUM VSF katalogda belirtildiği gibi herhangi bir pozisyonda konumlandırılabilir. Sadece 90 ve 105 gövdelerin V5/V6 montaj pozisyonları için kullanım şartlarını belirlemek üzere teknik servise başvurunuz.
- 110, 130 ve 150 gövde boyutları AGIP BLASIA 460 mineral yağı kullanılmaktadır.
- 110-130 ve 150 boyutları için pozisyonları belirtmek gerekmektedir, aksi takdirde redüktör B3 montaj pozisyonuna göre yağ miktarı ile tedarik edilir.
- Sadece 110-130 ve 150 gövde büyüklüğündeki redüktörlerde havalandırma (delikli) tapası, seviye ve yağ tapası (deliksiz) ile birlikte satılmaktadır.
- Montaj işleminden sonra nakliye için kullanılan havalandırma (delikli) tapası, havalandırma (deliksiz) tapası ile değiştirilmesi gerekir.
- Ön kademe helis dişli şekilli modüller uzun ömürlü yağ, sentetik yağ, AGIP TELIUM VSF ile birlikte tedarik edilir ve her türlü pozisyonda yerleştirilebilirler. Yağlama işlemi ikinci kademe sonsuz redüktör dişlilerinden ayrıdır.

**EN** LUBRICATION

- The reduction units size 030-040-050-063-075-090-105 are supplied complete with lubricant for life, synthetic oil, AGIP TELIUM VSF and can therefore be mounted in any position envisaged in the catalogue. The only exceptions are 090 and 105 in pos. V5/V6 for which you should call our Technical Service to assess the conditions of use.
- The reduction units size 110-130 and 150 are supplied complete with lubricant, mineral oil, AGIP BLASIA 460.
- For sizes 110-130 and 150 it is necessary to specify the position, otherwise the reduction units are supplied with the quantity of oil relating to pos. B3.
- Only reduction units 110-130 and 150 are fitted with breather, level and oil drainage plugs. It is necessary, after installation, to replace the closed plug used for transportation with the breather plug supplied with the unit.
- The pre-stage helical modules are supplied complete with life-long lubricant, synthetic oil, AGIP TELIUM VSF, and can therefore be mounted in all the positions. Lubrication is separated from that of the worm reduction unit.

**DE** SCHMIERUNG

- Die Getriebegrößen 030-040-050-063-075-090-105 werden mit Langzeitschmiermittel, und zwar Synthetiköl (Polyglykol-Öl) AGIP TELIUM VSF, geliefert und können daher in jeder im Katalog vorgesehenen Einbaulage montiert werden, mit Ausnahme der Größen 090 und 105 in der Pos V5/V6. Hier sollten die Einsatz - bedingungen mit unserem Kundendienst diskutiert werden.
- Die Getriebegrößen 110-130 und 150 werden mit Mineralöl AGIP BLASIA 460 geliefert.
- Für die Größen 110 - 130 und 150 ist eine von B3 abweichende Einbaulage immer genau anzugeben; andernfalls werden die Getriebe mit der für die Position B3 geeigneten Ölmenge geliefert.
- Nur die Getriebegrößen 110-130 und 150 sind mit Einfüll-Entlüftungs - Ölstand - und Ölablaßschraube versehen; nach dem Einbau muß der als Transportschutz angebrachte Verschlußdeckel gegen die beiliegende Entlüftungsschraube ausgewechselt werden.
- Die Vorstufen werden mit Langzeitschmiermittel, und zwar Polyglykol-Synthetiköl AGIP TELIUM VSF geliefert und können daher in jeder Einbaulage montiert werden. Die Schmierung der Vorstufe ist von der des Schneckengetriebes getrennt.

**IT** LUBRIFICAZIONE

- I riduttori delle gr. 030-040-050-063-075-090-105 vengono forniti completi di lubrificante a vita, olio a base sintetica, AGIP TELIUM VSF e pertanto possono essere montati in tutte le posizioni di piazzamento previste a catalogo. Fanno eccezione le gr. 090 - 105 nella pos. V5/V6 per la quale è opportuno rivolgersi al ns. Servizio Tecnico per valutare le condizioni di impiego.
- I riduttori gr. 110-130 e 150 vengono forniti completi di lubrificante, olio a base minerale, AGIP BLASIA 460.
- Per le gr. 110-130 e 150 occorre sempre specificare la posizione di piazzamento, se questo non avviene i riduttori vengono forniti con le q.tà di olio relative alla pos. B3.
- Solo i riduttori gr. 110-130 e 150 sono provvisti dei tappi di carico/sfiato, livello e scarico olio; si raccomanda, effettuata l'installazione, di sostituire il tappo chiuso utilizzato per il trasporto, con il tappo di sfiato allegato al gruppo.
- Le precoppie vengono fornite complete di lubrificante a vita, olio a base sintetica, AGIP TELIUM VSF e pertanto possono essere montate in tutte le posizioni di piazzamento. La lubrificazione della precoppia è separata da quella del riduttore a vite.

**FR** LUBRIFICATION

- Les réducteurs de taille 030-040-050-063-075-090-105 sont livrés avec lubrifiant à vie, soit huile synthétique AGIP TELIUM VSF, et peuvent être montés dans toutes les positions de montage prévues dans le catalogue, à l'exception de la taille 090 et 105 dans la pos. V5/V6 pour laquelle il faut contacter notre Service technique, afin d'évaluer les conditions d'emploi.
- Les réducteurs de taille 110-130 et 150 sont livrés avec lubrifiant, soit huile minérale AGIP BLASIA 460.
- Pour les tailles 110-130 et 150, il faut toujours spécifier la position de montage; dans le cas contraire, les réducteurs seront livrés avec les quantités d'huile correspondant à la pos. B3.
- Seulement les réducteurs de taille 110-130 et 150 sont livrés avec des bouchons de remplissage/d'évent et de vidange d'huile; on recommande, une fois l'installation effectuée, de remplacer le bouchon, utilisé lors du transport, par le bouchon d'évent fourni avec le groupe.
- Les précouples sont livrés avec lubrifiant à vie, soit huile synthétique AGIP TELIUM VSF et peuvent donc être montés dans toutes les positions. La lubrification du précouple est séparée de celle du réducteur à vis.

**ES** LUBRICACIÓN

- Los reductores de los tamaños 030-040-050-063-075-090-105 son entregados con lubricante a vida, es decir aceite sintético AGIP TELIUM VSF y por lo tanto pueden ser montados en todas las posiciones de montaje previstas en el catálogo, e excepción de los tamaños 090 y 105 en la pos. V5/V6 para la cual es necesario ponerse en contacto con nuestro Servicio técnico para evaluar las condiciones de empleo.
- Los reductores de los tamaños 110-130 y 150 son entregados con lubricante, es decir aceite mineral AGIP BLASIA 460.
- Para los tamaños 110-130 y 150 siempre es necesario detallar la posición de montaje; en caso contrario, los reductores serán entregados con las cantidades de aceite previstas para la pos. B3.
- Solo los reductores de tamaño 110-130 y 150 están equipados de tapones de carga/respiradero, de nivel y descarga aceite; recomendamos, una vez efectuada la instalación, de reemplazar el tapón cerrado, utilizado durante el transporte, por el tapón-respiradero entregado con el grupo.
- Los pre-reductores son entregados con lubricante a vida, es decir aceite sintético AGIP TELIUM VSF y pueden por lo tanto ser montados en todas las posiciones de montaje. La lubricación del pre-reductor es separada de la del reductor de tornillo sinfin.

PMRV	030	040	050	063	075	090	105	110	130	150
B3	0.04	0.08	0.15	0.3	0.55	1	1.6	3	4.5	7
B8								2.2	3.3	5.1
B6-B7								2.5	3.5	5.4
V5								3	4.5	7
V6								2.2	3.3	5.1
PPC	063	071	080	090						
B3 - B8	0,05	0,07	0,15	0,16						
B6 - B7										
V5 - V6										

- Litre cinsinden yağ miktarı ~
- Quantity of oil in litres ~
- Ölmenge (Liter) ~
- Quantità olio in litri ~
- Quantité d'huile en litres ~
- Cantidad de aceite en litros ~

## TR YÜZEY İŞLEME ÖZELLİKLERİ

Polat ürünleri aşağıdaki yüzey işleme özellikleri ile birlikte tedarik edilirler:

**Dişliler için alüminyum alaşımlı enjeksiyon döküm gövdeler.**  
Enjeksiyon döküm malzemeler aşağıdaki yüzey temizleme işlemlerinden geçmektedir:

- Mekanik olarak işletilen makaslama sistemi ile çapak temizleme.
- Mükemmel bilyalı bombarduman
- Boyama
- Yıkama ve koruma

**Dişliler için gri renkli enjeksiyon kalıp gövdeler.**

Enjeksiyon kalıp malzemeler her zaman boyanır. Polat Redüktörleri üzerinde kullanılan boya (eğer gerekiyorsa) aşağıdaki özellikleri karşılar:

**Tanım**

- Portakal kabuğu görümlü mavi-renkli epoksipoliester RAL 5010.

**Kullanılan ürün:**

- Poliester reçine bazlı ısı-sertleştirici tozlar, epoksi reçinesi ile işleme tabi tutulmuş.

**Mekanik özellikler**

- Testler yağı alınmış Unichim beyaz kaplama üzerinde yapılmaktadır. (Film kalınlığı:60 mikron), aşağıdaki teknik özelliklerle uyumludur:

Yapışkanlık (ISO2409), Erichsen çizimi (ISO152), ters şoklama (DIN53158), konik şekilli maça (DIN53151), sertlik (ASTM D3363/74).

**Isıya Dayanıklılık**

- 24 Saat 150 C°'de

**Korozyona Karşı Dayanıklılık**

- Prosesleri desteklemeye bağlı olarak 100-500 saate kadar tuz sisi.

## EN SURFACE TREATMENT SPECIFICATIONS

Polat products are supplied with the following surface treatment features:

**Die-cast aluminium alloy cases for gears.**

Die-cast materials undergo the following surface cleaning operations:

- De-burring by means of a mechanically operated shearing system.
- Accurate shot-peening
- Painting
- Washing and passivation

**Grey-coloured cast-iron cases for gears:**

Die-cast materials are always painted. Painting used on Polat reduction units (if required) meets the following specifications:

**Description**

- Orange-peel blue - coloured epoxy - polyester RAL 5010

**Product used:**

- Polyester resin based heat-hardening powders, altered with epoxy resins.

**Mechanical properties**

- Tests carried out onto degreased Unichim white latters (film thickness: 60 microns) comply with the following specifications:

Adherence (ISO2409), Erichsen drawing (ISO152), inverted shock (DIN53158), cone-shaped mandrel (DIN53151), hardness (ASTM D3363/74).

**Heat resistance**

- 24 Hours at 150°C.

**Corrosion strength**

- ASTM B 117/97 salt fog from 100 to 500 hours depending on the support's preliminary treatment.

## DE SPEZIFIKATION DER OBERFLÄCHENBEHANDLUNG

Die Polat-Produkte werden mit folgender Oberflächenbehandlung geliefert.

**Gehäuse aus druckgegossener Alulegierung:**

Die Gussteile werden, folgender Oberflächenbehandlung unterzogen:

- Entgratung des Rohgusses
- Sorgfältige Kugelstrahlung
- Lackierung
- Wäsche und Passivierung.

**Baugruppen aus Grauguss:**

Die Gussteile werden immer lackiert. Die aufgetragene Lackierung erfolgt nach folgender Spezifikation:

**Beschreibung**

- Epoxydpolyester - Pulverbeschichtung, Blau RAL5010

**Verwendetes Produkt**

- Wärmehärtendes, auf Polyesterharzen basierendes und mit Epoxydharz modifiziertes Pulver.

**Mechanische Eigenschaften**

- Die Tests, die auf entfetteten Unichim-Blechen mit 60-Mikron Filmdicke durchgeführt wurden, haben folgende Anforderungen erfüllt:

Haftvermögen (ISO2409), Ziehen nach Erichsen (ISO1520), umgekehrter Stoss (DIN53158), konische Spindel (DIN53151), Härte (ASTM D3363/74).

**Wärmebeständigkeit**

- 24 Stunden Bei 150°C.

**Korrosionsbeständigkeit**

- Salznebel ASTM B 117/97 von 100 bis 500 Stunden, je nach Vorbehandlung des Untergrundes.

**IT SPECIFICHE DI FINITURA SUPERFICIALE**

I prodotti Polat vengono forniti con il seguente stato di finitura superficiale.

**Gruppi con casse in lega di alluminio pressofuso:**

Le fusioni subiscono le seguenti operazioni di pulizia superficiale:

- Eliminazione delle bave di fonderia con sistemi meccanici di asportazione (trancianti).
- Accurata pallinatura.
- Verniciatura.
- Lavaggio e passivazione.

**Gruppi con casse in grigia:**

Le fusioni vengono sempre verniciate.

La verniciatura adottata sui gruppi Polat (ove prevista) soddisfa le seguenti specifiche:

**Descrizione**

- Epossipoliestere Blu Bucciato RAL 5010

**Prodotto Utilizzato**

- Polvere termoidurente a base di resine poliesteri, modificate con resina epossidica.

**Proprietà meccaniche**

- Le prove eseguite su lamierini Unichim sgrassati con spessore del film di 60 microns hanno soddisfatto le seguenti caratteristiche:

Aderenza (ISO2409), imbutitura Erichsen (ISO1520), urto inverso (DIN53158), mandrino conico (DIN53151), durezza (ASTM D3363/74).

**Resistenza al calore**

- 24 ORE A 150°C.

**Resistenza alla corrosione**

- Nebbia salina ASTM B 117/97 da 100 a 500 ore in funzione del trattamento preliminare del supporto.

**FR SPÉCIFICATIONS SUR L' EXTÉRIEUR**

Les produits Polat sont fournis suivant l'état de finition suivant:

**Réducteurs avec carter aluminium moulé sous pression:**

Les carters bruts subissent les opérations de finition suivantes:

- Elimination des bavures, dues à la coulée, par des moyens mécaniques (ébarbeuse)
- Grenailage soigné
- Peinture
- Lavage et passivation

**Réducteurs avec carter en fonte:**

Les réducteurs sont toujours peints.

La peinture utilisée pour les réducteurs Polat est conforme aux spécifications suivantes:

**Description**

- Epoxy-polyester bleu "peau d'orange" RAL 5010

**Produit utilisé**

- Poudre thermodurcissable à base de résines polyester, modifiées avec des résines époxy.

**Propriétés mécaniques**

- Les essais réalisés sur des tôles minces Unichim dégraissées (épaisseur de la couche: 60 microns) sont conformes aux caractéristiques suivantes:

adhérence (ISO2409), emboutissage Erichsen (ISO1520), choc inversé (DIN 53158), mandrin conique (DIN 53151), dureté (ASTM D3363/74).

**Résistance à la chaleur**

- 24 Heures à 150°C.

**Résistance à la corrosion**

- Brouillard salin ASTM B 117/97 de 100 à 500 heures, compte tenu du traitement préliminaire du support.

**ES CARACTERÍ DE SUMINISTRO SUPERFICIAL**

Los productos Polat se entregan con el siguiente estado de acabado superficial.

**Unidades con cajas de aleación de aluminio fundido a presión:**

Se realizan las siguientes operaciones de limpieza superficial en las cajas:

- Eliminación de las barbas de fundición mediante sistemas mecánicos de corte.
- Granallado de alta precisión.
- Pintado
- Lavado y pasivación.

**Unidades con cajas de fundición gris:**

Las cajas se pintan siempre.

La pintura utilizada sobre las unidades Polat (donde está prevista su aplicación) cumple las siguientes condiciones:

**Descripción**

- Epoxipoliéster Azul Marino RAL5010

**Producto utilizado**

- Polvo termoestable a base de resinas poliéster, modificadas con resina epoxídica.

**Propiedades mecánicas**

- Las pruebas realizadas con las chapas finas Unichim desengrasadas con grosor del film de 60 micrones han satisfecho las siguientes exigencias:

Adherencia (ISO2409), embutición Erichsen (ISO1520), golpe inverso (DIN 53158), mandril cónico (DIN 53151), dureza (ASTM D3363/74).

**Resistencia a la corrosión**

- 24 Horas a 150°C.

**Resistencia a la corrosión**

- Niebla salina ASTM B 117/97 de 100 a 500 horas en función del tratamiento preliminar del soporte.



A large area of the page is filled with horizontal dotted lines, serving as a template for writing or drawing.



Sonsuz vida diřli motorlar  
ve vida diřli takımlar

Worm geared motors  
and worm gear units

Schneckengetriebemotoren  
und Schneckengetriebe

Motoriduttori e riduttori  
a vite senza fine

Motoréducteurs et réducteurs  
à vis sans fin

Motorreductores y reductores  
de tornillo sinfin

**PMRV**

**PMRV...**

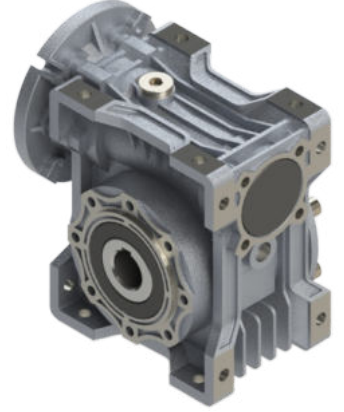

**PRV...**



**PMRV+PMRV...**

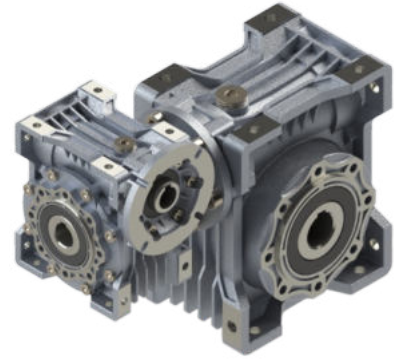

**PPC+PMRV...**

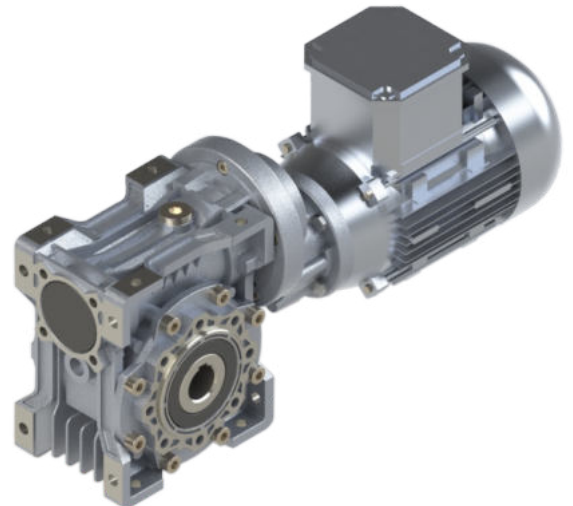

TR	TASARIM	EN	DESIGNATION	DE	BEZEICHNUNG
IT	DESIGNAZIONE	FR	DÉSIGNATION	ES	DESIGNACIÓN

## PMRV - PRV

<b>PMRV</b>	Sonsuz vida dişli redüktörlü motor Worm geared motor Schneckengetriebemotor Motoriduttore a vite senza fine predisposto per motore Motorréducteur à vis sans fin Motorreductor de tornillo sinfin		
<b>PRV</b>	Motorsuz sonsuz vida dişli redüktör Worm reduction unit Schneckengetriebe (mit Einganswelle) Riduttore a vite senza fine Réducteur à vis sans fin Reductor de tornillo sinfin		
<b>050</b>	Gövde Büyüklüğü / Size Größe / Grandezza Taille / Tamaño		
<b>FA-FB-FC FD-FE</b>	Çıkış flanşı / Output flange Abtriebsflansch / Flangia di uscita Bride de sortie / Brida de salida		
<b>30</b>	Tahvil oranı Reduction ratio Übersetzungsverhältnis Rapporto di riduzione Rapport de réduction Relación de reducción		
<b>PAM</b>	Motor akuplajına ekleme Fitted for motor coupling Für motoranbau vorbereitet Predisposto per attacco motore Prédisposé pour montage moteur standard Predispuesto para montaje motor		
<b>200</b>	Motor flanş çapı Motor flange diameter Motorflansch-Durchmesser Diametro flangia motore Diamètre bride moteur Diámetro brida motor	<b>19</b>	Vida giriş şaftı çapı Drive-shaft diameter Motorwellen-Durchmesser Diametro albero motore Diamètre arbre moteur Diámetro eje motor
<b>VS</b>	Çift girişli şaft Double input shaft Schnecke mit doppeltem wellenende Vite senza fine bisporgente Vis double sortie Tornillo sinfin prolongado	<b>AS</b>	Tek çıkışlı şaft Single output shaft Einseitige Abtriebswelle Albero di uscita semplice Arbre de sortie simple Eje de salida sencillo
<b>AB</b>	Çift çıkışlı şaft Double output shaft Doppelseitige Abtriebswelle Albero di uscita doppio Arbre de sortie double Eje de salida doble	<b>B3</b>	Montaj pozisyonu Mounting position Einbaulage Posizione di piazzamento Position de montage Posición de montaje
<b>0,75 kW</b>	Elektrik motor gücü Electric motor power Elektromotor-Leistung Potenza motore elettrico Puissance moteur électrique Potencia motor eléctrico	<b>4P</b>	Elektrik motor polaritesi Electric motor polarity Elektromotor-Polarität Polarità motore elettrico Polarité moteur électrique Polaridad motor eléctrico
<b>230/400V</b>	Elektrik motor voltajı Electric motor voltage Elektromotor-Spannung Voltaggio motore elettrico Voltage moteur électrique Voltaje motor eléctrico	<b>50 Hz</b>	Elektrik motor frekansı Electric motor frequency Elektromotor-Frequenz Frequenza motore elettrico Fréquence moteur électrique Frecuencia motor eléctrico

TR	TASARIM	EN	DESIGNATION	DE	BEZEICHNUNG
IT	DESIGNAZIONE	FR	DÉSIGNATION	ES	DESIGNACIÓN

**PPC + PMRV**

<b>PPC</b>	Ön kademeli helisel modül / Pre-stage helical module Übersetzungsvorstufe / Precoppia di riduzione Précouple de réduction / Pre-reducción		
<b>71</b>	Ebatları / Size Größe / Grandezza Taille / Tamaño		
<b>PMRV</b>	Sonsuz vida dişli redüktörlü motor Worm geared motor Schneckengetriebemotor Motoriduttore a vite senza fine predisposto per motore Motorréducteur à vis sans fin Motorreductor de tornillo sinfin		
<b>050</b>	Gövde Büyüklüğü / Size Größe / Grandezza Taille / Tamaño		
<b>FA-FB-FC FD-FE</b>	Çıkış flanşı / Output flange Abtriebsflansch / Flangia di uscita Bride de sortie / Brida de salida		
<b>300</b>	Tahvil oranı Reduction ratio Übersetzungsverhältnis Rapporto di riduzione Rapport de réduction Relación de reducción		
<b>PAM</b>	Motor akuplajına ekleme Fitted for motor coupling Für motoranbau vorbereitet Predisposto per attacco motore Prédisposé pour montage moteur standard Predispuerto para montaje motor		
<b>160</b>	Motor flanş çapı Motor flange diameter Motorflansch-Durchmesser Diametro flangia motore Diamètre bride moteur Diámetro brida motor	<b>14</b>	Vida giriş şaftı çapı Drive-shaft diameter Motorwellen-Durchmesser Diametro albero motore Diamètre arbre moteur Diámetro eje motor
<b>VS</b>	Çift girişli şaft Double input shaft Schnecke mit doppeltem wellenende Vite senza fine bisporgente Vis double sortie Tornillo sinfin prolongado	<b>AS</b>	Tek çıkışlı şaft Single output shaft Einseitige Abtriebswelle Albero di uscita semplice Arbre de sortie simple Eje de salida sencillo
<b>AB</b>	Çift çıkışlı şaft Double output shaft Doppelseitige Abtriebswelle Albero di uscita doppio Arbre de sortie double Eje de salida doble	<b>B3</b>	Montaj pozisyonu Mounting position Einbaulage Posizione di piazzamento Position de montage Posición de montaje
<b>0,75 kW</b>	Elektrik motor gücü Electric motor power Elektromotor-Leistung Potenza motore elettrico Puissance moteur électrique Potencia motor eléctrico	<b>4P</b>	Elektrik motor polaritesi Electric motor polarity Elektromotor-Polarität Polarità motore elettrico Polarité moteur électrique Polaridad motor eléctrico
<b>230/400V</b>	Elektrik motor voltajı Electric motor voltage Elektromotor-Spannung Voltaggio motore elettrico Voltage moteur électrique Voltaje motor eléctrico	<b>50 Hz</b>	Elektrik motor frekansı Electric motor frequency Elektromotor-Frequenz Frequenza motore elettrico Fréquence moteur électrique Frecuencia motor eléctrico

TR	TASARIM	EN	DESIGNATION	DE	BEZEICHNUNG
IT	DESIGNAZIONE	FR	DÉSIGNATION	ES	DESIGNACIÓN

## PMRV+PMRV - PRV+PMRV

<b>PMRV + PMRV</b>	Kombine sonsuz vida dişli redüktörlü motor Combined worm geared motor Zweistufiger Schneckengetriebemotor Motoriduttore a vite senza fine combinato Motorréducteur à vis sans in combiné Motorreductor de tornillo sinfin combinado		
<b>PRV + PMRV</b>	Kombine (motorlu - motorsuz) sonsuz vida dişli redüktörler Combined worm reduction unit Zweistufiges Schneckengetriebe (mit eingangswelle) Riduttore a vite senza fine combinato Réducteur à vis sans fin combiné Reductor de tornillo sinfin combinado		
<b>050/110</b>	Gövde Büyüklüğü / Size Größe / Grandezza Taille / Tamaño		
<b>FA-FB-FC FD-FE</b>	Çıkış flanş / Output flange Abtriebsflansch / Flangia di uscita Bride de sortie / Brida de salida		
<b>900</b>	Tahvil oranı / Reduction ratio Übersetzungsverhältnis / Rapporto di riduzione Rapport de réduction / Relación de reducción		
<b>PAM</b>	Motor akuplajına ekleme Fitted for motor coupling Für motoranbau vorbereitet Predisposto per attacco motore Prédisposé pour montage moteur standard Predispuesto para montaje motor		
<b>200</b>	Motor flanş çapı Motor flange diameter Motorflansch-Durchmesser Diametro flangia motore Diamètre bride moteur Diámetro brida motor	<b>19</b>	Vida giriş şaftı çapı Drive-shaft diameter Motorwellen-Durchmesser Diametro albero motore Diamètre arbre moteur Diámetro eje motor
<b>VS</b>	Çift girişli şaft Double input shaft Schnecke mit doppeltem wellenende Vite senza fine bisporgente Vis double sortie Tornillo sinfin prolongado	<b>AS</b>	Tek çıkışlı şaft Single output shaft Einseitige Abtriebswelle Albero di uscita semplice Arbre de sortie simple Eje de salida sencillo
<b>AB</b>	Çift çıkışlı şaft Double output shaft Doppelseitige Abtriebswelle Albero di uscita doppio Arbre de sortie double Eje de salida doble	<b>BS1</b>	Çalışma Execution Paarungsform Esecuzione Exécution Ejecución
<b>B3</b>	Montaj pozisyonu / Mounting position Einbaulage / Posizione di piazzamento Position de montage / Posición de montaje		
<b>0,75 kW</b>	Elektrik motor gücü Electric motor power Elektromotor-Leistung Potenza motore elettrico Puissance moteur électrique Potencia motor eléctrico	<b>4P</b>	Elektrik motor polaritesi Electric motor polarity Elektromotor-Polarität Polarità motore elettrico Polarité moteur électrique Polaridad motor eléctrico
<b>230/400V</b>	Elektrik motor voltajı Electric motor voltage Elektromotor-Spannung Voltaggio motore elettrico Voltage moteur électrique Voltaje motor eléctrico	<b>50 Hz</b>	Elektrik motor frekansı Electric motor frequency Elektromotor-Frequenz Frequenza motore elettrico Fréquence moteur électrique Frecuencia motor eléctrico

TR PREPOZİSYONLAMA

EN PREDISPOSITION

DE MOTORANBAU

IT PREDISPOSIZIONE

FR PRÉDISPOSITION

ES PREDISPOSICIÓN

- (\*) Kama derinliği standart dışıdır.
- (\*) Low profile key supplied by Polat.
- (\*) Abgeflachte Paßfeder im Lieferumfang
- (\*) Linguetta ribassata di nostra fornitura.
- (\*) Clavette surbaissée fournie.
- (\*) Chavetero rebajado de nuestro suministro.

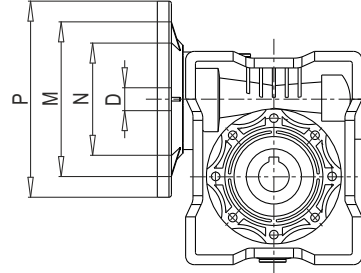

PMRV	PAM IEC	N	M	P	D												
					5	7,5	10	15	20	25	30	40	50	60	80	100	
030	63B5	95	115	140	11	11	11	11	11	11	11	11	11	11	11	11	-
	63B14	60	75	90													
	56B5	80	100	120	9	9	9	9	9	9	9	9	9	9	9	9	-
	56B14	50	65	80													
040	71B5	110	130	160	14	14	14	14	14	14	14	14	14	14	14	14	14
	71B14	70	85	105													
	63B5	95	115	140	11	11	11	11	11	11	11	11	11	11	11	11	11
	63B14	60	75	90													
050	56B5	80	100	120	-	-	-	-	-	-	-	-	-	9	9	9	9
	80B5	130	165	200	19	19	19	19	19	19	19	19	19	19	19	19	-
	80B14	80	100	120													
	71B5	110	130	160	14	14	14	14	14	14	14	14	14	14	14	14	14
063	71B14	70	85	105													
	63B5	95	115	140	-	-	-	-	-	-	-	-	11	11	11	11	11
	90B5	130	165	200	-	24	24	24	24	24	24	24	24	24	24	-	-
	90B14	95	115	140													
	80B5	130	165	200	-	19	19	19	19	19	19	19	19	19	19	19	19
	80B14	80	100	120													
075	71B5	110	130	160	-	-	-	-	-	-	-	-	14	14	14	14	14
	100/112B5	180	215	250	-	28	28	28	28	28	28	28	28	-	-	-	-
	100/112B14	110	130	160													
	90B5	130	165	200	-	24	24	24	24	24	24	24	24	24	24	24	24
	90B14	95	115	140													
	80B5	130	165	200	-	-	-	-	19	19	19	19	19	19	19	19	19
090	80B14	80	100	120													
	71B5	110	130	160	-	-	-	-	-	-	-	-	14	14	14	14	14
	100/112B5	180	215	250	-	28	28	28	28	28	28	28	28	28	28	28	-
	100/112B14	110	130	160													
	90B5	130	165	200	-	24	24	24	24	24	24	24	24	24	24	24	24
	90B14	95	115	140													
105	80B5	130	165	200	-	-	-	-	-	-	-	19	19	19	19	19	19
	132B5	230	265	300	-	38*	38*	38*	38*	38*	38*	38*	38*	38*	38*	-	-
	100/112B5	180	215	250	-	28	28	28	28	28	28	28	28	28	28	28	28
	100/112B14	110	130	160													
110	90B5	130	165	200	-	-	-	-	-	24	24	24	24	24	24	24	24
	80B5	130	165	200	-	-	-	-	-	-	-	-	-	-	-	19	19
	132B5	230	265	300	-	38*	38*	38*	38*	38*	38*	38*	38*	38*	38*	-	-
	100/112B5	180	215	250	-	28	28	28	28	28	28	28	28	28	28	28	28
130	100/112B14	110	130	160													
	90B5	130	165	200	-	-	-	-	-	-	-	-	-	-	-	24	24
	132B5	230	265	300	-	38*	38*	38*	38*	38*	38*	38*	38*	38*	38*	38*	38*
	100/112B5	180	215	250	-	-	-	-	-	28	28	28	28	28	28	28	28
150	100/112B14	110	130	160													
	132B5	230	265	300	-	-	-	-	38	38	38	38	38	38	38	38	38
	132B14	130	165	200													
	100/112B5	180	215	250	-	-	-	-	-	-	-	-	-	28	28	28	28

- Daire içindeki ölçüler standart dışı olarak üretilebilir.
- In circle there are the diameters possible but they are not in the catalogue
- Im Kreis sind die möglichen Durchmesser dargestellt, können auch aussen standart grössen produziert werden.
- Nel Cerchio sono scritti i diametri disponibili, ma possono essere prodotti anche nelle misure fuori standart.
- Dans le cercle est un diamètre écrites disponibles, mais peuvent également être produits dans des tailles standart sur.
- En el Círculo es diámetros escritos disponibles, pero también se pueden producir en tamaños Standart cabo.

TR PPC+PMRV KOMBİNASYONLARI  
IT COMBINAZIONI

EN COMBINATIONS  
FR COMBINAISONS

DE KOMBINATIONEN  
ES COMBINACIONES

PMRV	i	PPC 063		PPC 071		PPC 080			PPC 090		
		105 / 11 i = 3	105 / 14 i = 3	120 / 14 i = 3	120 / 19 i = 3	160 / 19 i = 3	160 / 24 i = 3	160 / 28 i = 3	160 / 19 i = 2,42	160 / 24 i = 2,42	160 / 28 i = 2,42
040	25										
	30										
	40										
	50										
	60										
	80										
100											
050	25										
	30										
	40										
	50										
	60										
	80										
100											
063	25										
	30										
	40										
	50										
	60										
	80										
100											
075	25										
	30										
	40										
	50										
	60										
	80										
100											
090	25										
	30										
	40										
	50										
	60										
	80										
100											
105	25										
	30										
	40										
	50										
	60										
	80										
100											
110	25										
	30										
	40										
	50										
	60										
	80										
100											
130	25										
	30										
	40										
	50										
	60										
	80										
100											

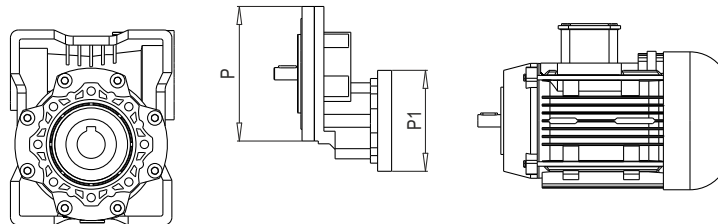

	P1	P	(P)
PPC 063	63B5 - 140 / 11	105 / 11	105 / 14
PPC 071	71B5 - 160 / 14	120 / 14	120 / 19
PPC 080	80B5 - 200 / 19	160 / 19	160 / 24 160 / 28
PPC 090	90B5 - 200 / 24	160 / 24	160 / 19 160 / 28

(..) Sadece talebe bağı olarak  
(..) Only on request  
(..) Auf Wunsch  
(..) Solo su richiesta  
(..) Seulement sur demande  
(..) Sólo bajo pedido

VERSİYONLAR / VERSIONS / AUSFÜHRUNGEN / VERSIONI / VERSIONS / VERSIONES

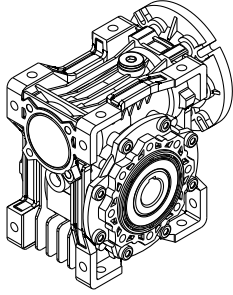

**PMRV 030-150**

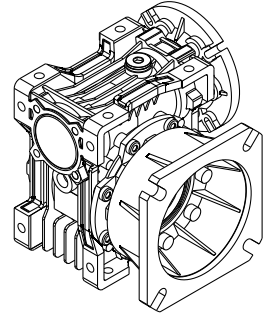

**PMRV 030-150 F**

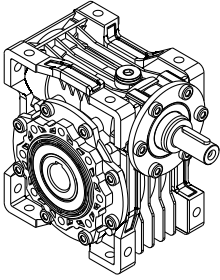

**PRV 030-150**

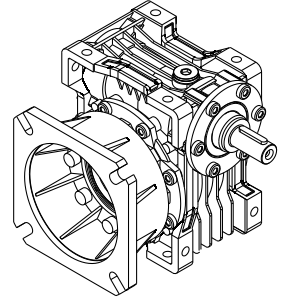

**PRV 030-150 F**

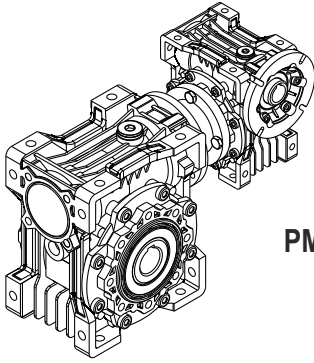

**PMRV+PMRV...**

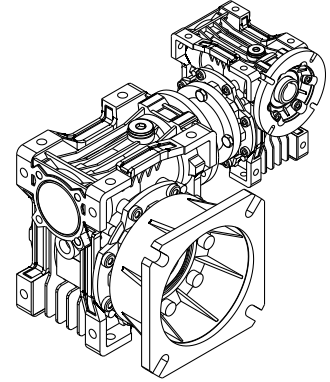

**PMRV+PMRV...F**

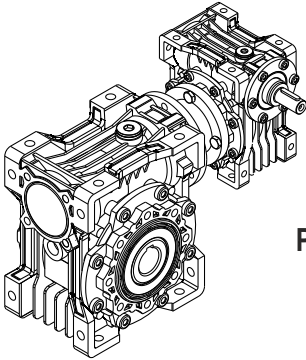

**PRV+PMRV...**

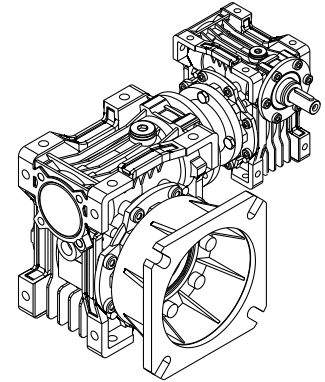

**PRV+PMRV...F**

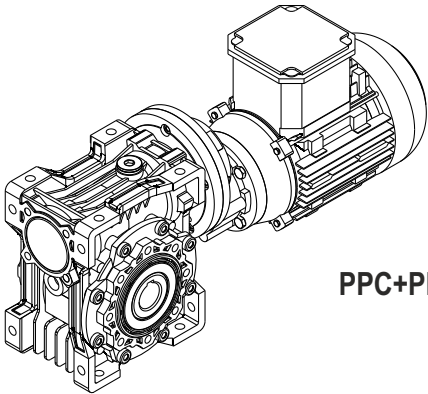

**PPC+PMRV...**

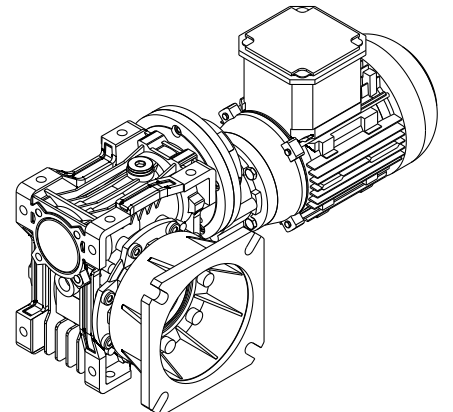

**PPC+PMRV...F**

## TR VERİMLİLİK

Etkinlik belirli uygulamalar üzerinde belirgin etki alanına sahip olan bir parametredir ve temel olarak çift dişli tasarımına göre değişkenlik gösterir. Konu ile ilgili olarak sayfa 30'da verilen bilgi dinamik etkinliği ( $n_1=1400$ ) ve statik etkinlik değerlerini gösterir. Bu değerlerin sadece makinanın çalıştığı sırada elde edildiğini aklınızdan çıkartmayın.

**DİNAMİK GERİ DÖNÜLMEZLİK (OTOBLOKAJ)**

Dinamik geri dönüşmezlik güç şaft dişlisi boyunca aktarıldığına göre bu sırada da çıkış şaftının durmasıyla elde edilir. Bu durum  $\eta_d < 0.5$  ölçüsünde dinamik etki gerektirir (sayfa 30'daki tabloya bakınız).

**STATİK GERİ DÖNÜLMEZLİK (OTOBLOKAJ)**

Statik geri dönüşmezlik dişli yavaşlatma takımı sabit konumda iken elde edilir, çıkış şaftına giden yük uygulaması dişli şaftı hare-ketinde oluşmaz. Bu durum  $\eta_s < 0.5$  ölçüğünde statik etkinlik gerektirir (sayfa 30'daki tabloya bakınız).

## EN EFFICIENCY

Efficiency is a parameter which has a major influence on the sizing of certain applications and basically depends on gear pair design elements.

The mesh data table on page 30 shows dynamic efficiency ( $n_1=1400$ ) and static efficiency values. Remember that these values are only achieved after the unit has been run in.

**DYNAMIC IRREVERSIBILITY**

Dynamic irreversibility is achieved when the output shaft stops instantly when drive is no longer through the worm shaft. This condition requires a dynamic efficiency of  $\eta_d < 0.5$  (see table on page 30).

**STATIC IRREVERSIBILITY**

Static irreversibility is achieved when, with the gear reducer at a standstill, the application of a load to the output shaft does not set in motion the worm shaft. This condition requires a static efficiency of  $\eta_s < 0.5$  (see table on page 30).

## DE WIRKUNGSGRAD

Der Wirkungsgrad ist für die Art der Anwendung wichtig. Er wird entscheidend von den Verzahnungsdaten beeinflusst. In der Übersicht der Verzahnungsdaten (S.30) finden Sie die Werte des dynamischen ( $n_1=1400$ ) und statischen Wirkungsgrades. Es wird darauf hingewiesen, daß diese Tabellenwerte erst nach der Einlaufzeit gültig sind.

**DYNAMISCHE SELBSTHEMMUNG**

Im Zustand dynamischer Selbsthemmung tritt sofortiger Stillstand der Abtriebswelle ein, wenn die Schneckenwelle nicht mehr angetrieben wird. Die theoretische Voraussetzung für dynamische Selbsthemmung ist ein dynamischer Wirkungsgrad  $\eta_d < 0.5$  (Tab. Seite 30).

**STATISCHE SELBSTHEMMUNG**

Bei statischer Selbsthemmung ist ein Anlauf aus dem Stillstand bei treibendem Schneckenrad nicht möglich. Statische Selbsthemmung liegt bei einem statischen Wirkungsgrad  $\eta_s < 0.5$  vor (Tab. Seite 30).

## IT RENDIMENTO

Un parametro che influisce in maniera determinante nella definizione di talune applicazioni è il rendimento.

Il rendimento dipende essenzialmente da elementi definiti dal progettista all'atto del progetto della coppia. La tabella dei dati di dentatura (pag.30) riporta i valori di rendimento dinamico ( $n_1=1400$ ) e rendimento statico. I valori indicati vengono raggiunti solo dopo la fase di rodaggio.

**IRREVERSIBILITÀ DINAMICA**

L'irreversibilità dinamica si realizza quando al venir meno del moto sull'asse della vite, si ha un arresto istantaneo del moto sull'asse dell'albero lento. Questa condizione si realizza quando il rendimento dinamico è  $\eta_d < 0.5$  (tab. pag.30).

**IRREVERSIBILITÀ STATICA**

L'irreversibilità statica si realizza quando, a riduttore fermo, l'applicazione di un carico all'albero lento non mette in movimento l'asse della vite. Questa condizione si realizza quando il rendimento statico è  $\eta_s < 0.5$  (tab. pag.30).

## FR RENDEMENT

Le rendement est un facteur qui influe considérablement sur la définition de certaines applications.

Le rendement dépend principalement d'éléments définis par le concepteur au moment de la réalisation du projet du couple. Le tableau des données de denture (page 30) montre les valeurs de rendement dynamique ( $n_1=1400$ ) et de rendement statique. Noter que les valeurs indiquées ne sont atteintes qu'après la phase de rodage.

**IRREVERSIBILITÉ DYNAMIQUE**

L'irreversibilité dynamique s'obtient lorsqu'à l'interruption du mouvement sur l'axe de la vis correspond un arrêt instantané du mouvement sur l'arbre PV. Cette condition se réalise lorsque le rendement dynamique est  $\eta_d < 0.5$  (Tabl. page 30).

**IRREVERSIBILITÉ STATIQUE**

L'irreversibilité statique s'obtient lorsque, réducteur arrêté, l'application d'une charge sur l'arbre PV ne met pas l'axe de la vis.

Cette condition se réalise lorsque le rendement statique est  $\eta_s < 0.5$  (tabl. page 30).

## ES RENDIMIENTO

Un parámetro que reviste importancia fundamental en la definición de algunas aplicaciones es el rendimiento.

El rendimiento depende esencialmente de variables definidas por el proyectista al momento de definir el par. La tabla de los datos del dentado (pág. 30) indica los valores de rendimiento dinámico ( $n_1=1400$ ) y rendimiento estático. Los valores indicados son alcanzados sólo una vez concluida la fase de rodaje.

**IRREVERSIBILIDAD DINAMICA**

La irreversibilidad dinámica se produce cuando, al faltar el movimiento en el eje del tornillo, se produce una detención instantánea en el eje del árbol lento. Esta situación se produce cuando el rendimiento dinámico es  $\eta_d < 0.5$  (Tab. pág.30).

**IRREVERSIBILIDAD ESTÁTICA**

La irreversibilidad estática se produce cuando, con el reductor detenido, la aplicación de una carga al árbol lento no pone en movimiento el eje del tornillo.

Esta situación se produce cuando el rendimiento estático es  $\eta_s < 0.5$  (tab. pág. 30).



TR VERİMLİLİK

EN EFFICIENCY

DE WIRKUNGSGRAD

IT RENDIMENTO

FR RENDEMENT

ES RENDIMIENTO

$\eta_d$	DİNAMİK GERİ DÖNÜLMEZLİK	DYNAMIC IRREVERSIBILITY	DYNAMISCHE SELBSTHEMMUNG	IRREVERSIBILITA' DINAMICA	IRREVERSIBILITE DYNAMIQUE	IRREVERSIBILIDAD DINAMICA
> 0.6	dinamik geri döndürme	dynamic reversibility	dynamische Reversierbarkeit	reversibilità dinamica	réversibilité dynamique	reversibilidad dinámica
0.5 - 0.6	düşük düzeyli dinamik geri döndürme	low dynamic reversibility	kaum dynamisch reversierbar	reversibilità dinamica incerta	réversibilité dynamique incertaine	reversibilidad dinámica incierta
0.4 - 0.5	iyi düzeyde dinamik geri dönülmelik	good dynamic irreversibility	schwache dynamische Selbsthemmung	buona irreversibilità dinamica	bonne irréversibilité dynamique	adecuada irreversibilidad dinámica
< 0.4	dinamik geri dönülmelik	dynamic irreversibility	dynamische Selbsthemmung	irréversibilité dinamica	irréversibilité dynamique	irreversibilidad dinámica

$\eta_s$	SİTATİK GERİ DÖNÜLMEZLİK	STATIC IRREVERSIBILITY	STATISCHE SELBSTHEMMUNG	IRREVERSIBILITA' STATICA	IRREVERSIBILITE STATIQUE	IRREVERSIBILIDAD ESTATICA
> 0.55	statik geri döndürme	static reversibility	statische Reversierbarkeit	reversibilità statica	réversibilité statique	reversibilidad estática
0.5 - 0.55	düşük statik geri döndürme	low static reversibility	kaum statisch reversierbar	reversibilità statica incerta	réversibilité statique incertaine	reversibilidad estática incierta
< 0.5	statik geri dönülmelik	static irreversibility	statische Selbsthemmung	irreversibilità statica	irréversibilité statique	irreversibilidad estática

Yukarıdaki tabloda yaklaşık geri dönülmelik değerleri verilmiştir. Vibrasyon (titreşim) ve şoklar dişli yavaşlatma takımının geri dönülmelik özelliğini etkileyebilir. Kombine bir dişli takımının geri dönülmelik koşulları için ürün bazında her bir dişli kademesi için verilen etkinlik grubu değerlendirilmelidir, örn:  $\eta_{tot} = \eta_1 \times \eta_2$

The table shows approximate irreversibility classes. Vibrations and shocks can affect a gear reducer's irreversibility. For the irreversibility conditions of a combined geared unit one must consider that the efficiency of the group is given by the product of the efficiencies of each single reducer, i.e.:  $\eta_{tot} = \eta_1 \times \eta_2$

In der Übersicht sind die Angaben zur Selbsthemmung nur als Richtwerte wiedergegeben. Die oben genannten Bedingungen können durch Vibrationen oder Stöße beeinträchtigt werden. Bei der Prüfung der Selbsthemmung zweistufiger Schneckengetriebe ist zu beachten, daß sich der Gesamtwirkungsgrad aus dem Produkt beider einzelnen Wirkungsgrade ergibt, d.h.  $\eta_{tot} = \eta_1 \times \eta_2$

La tabella riporta classificazioni indicative sul grado di irreversibilità. La presenza di vibrazioni o urti può modificare le condizioni sopra descritte. Per le condizioni di irreversibilità di un riduttore o combinato occorre considerare che il rendimento del gruppo è il prodotto dei rendimenti dei singoli riduttori, cioè:  $\eta_{tot} = \eta_1 \times \eta_2$

La tableau montre la classification indicative sur le degré d'irréversibilité. La présence de vibrations ou de chocs peut modifier les conditions susmentionnées. Pour ce qui concerne les conditions d'irréversibilité d'un réducteur combiné il faut considérer que le rendement du groupe est donné par le produit des rendements de chaque réducteur, c'est à dire:  $\eta_{tot} = \eta_1 \times \eta_2$

La tabla indica clasificaciones genéricas sobre el grado de irreversibilidad. La presencia de vibraciones o choques podría modificar estos valores. Para calcular las condiciones de irreversibilidad de un reductor combinado, es necesario considerar el rendimiento del grupo, que es dado por el producto de los rendimientos de cada reductor, es decir:  $\eta_{tot} = \eta_1 \times \eta_2$

**TR** DİŞLİ VERİSİ

**EN** MESH DATA

**DE** VERZÄHNUNGSDATEN

**IT** DATI INGRANAMENTO

**FR** DONNÉES DES ENGRANAGES

**ES** DATOS ENGRANE

PRV	i	5	7,5	10	15	20	25	30	40	50	60	80	100
030	Z1	6	4	3	2	2	1	1	1	1	1	1	-
	$\gamma$	27°04'	18°49'	14°20'	9°40'	7°42'	5°35'	4°52'	3°52'	3°12'	2°45'	2°07'	-
	Mx	1,44	1,44	1,44	1,44	1,09	1,7	1,44	1,09	0,89	0,74	0,56	-
	$\eta_d$ (1400)	0,87	0,85	0,82	0,77	0,73	0,68	0,65	0,59	0,55	0,51	0,44	-
	$\eta_s$	0,72	0,67	0,63	0,55	0,5	0,43	0,39	0,35	0,31	0,27	0,23	-
040	Z1	6	4	3	2	2	2	1	1	1	1	1	1
	$\gamma$	34°19'	24°28'	18°51'	12°49'	10°23'	8°43'	6°29'	5°14'	4°23'	3°47'	2°57'	2°25'
	Mx	2,06	2,06	2,06	2,06	1,57	1,27	2,06	1,57	1,27	1,06	0,81	0,65
	$\eta_d$ (1400)	0,89	0,87	0,85	0,82	0,78	0,75	0,7	0,65	0,62	0,58	0,52	0,47
	$\eta_s$	0,74	0,71	0,67	0,6	0,55	0,51	0,45	0,4	0,36	0,32	0,28	0,24
050	Z1	6	4	3	2	2	2	1	1	1	1	1	1
	$\gamma$	33°37'	23°54'	18°23'	12°30'	10°06'	8°29'	6°19'	5°06'	4°16'	3°40'	2°52'	2°21'
	Mx	2,56	2,56	2,56	2,56	1,95	1,58	2,56	1,95	1,58	1,32	1	0,8
	$\eta_d$ (1400)	0,89	0,88	0,86	0,82	0,79	0,76	0,72	0,67	0,63	0,59	0,53	0,49
	$\eta_s$	0,74	0,7	0,66	0,59	0,55	0,51	0,44	0,39	0,35	0,32	0,27	0,23
063	Z1	-	4	3	2	2	2	1	1	1	1	1	1
	$\gamma$	-	24°31'	18°53'	12°51'	10°25'	8°45'	6°30'	5°15'	4°24'	3°47'	2°58'	2°26'
	Mx	-	3,25	3,25	3,25	2,48	2	3,25	2,48	2	1,68	1,27	1,02
	$\eta_d$ (1400)	-	0,88	0,87	0,83	0,81	0,78	0,74	0,7	0,66	0,62	0,57	0,51
	$\eta_s$	-	0,71	0,67	0,6	0,55	0,51	0,45	0,4	0,36	0,33	0,28	0,24
075	Z1	-	4	3	2	2	2	1	1	1	1	1	1
	$\gamma$	-	26°17'	20°20'	13°52'	11°18'	9°32'	7°02'	5°42'	4°48'	4°08'	3°14'	2°40'
	Mx	-	3,94	3,94	3,94	3	2,42	3,94	3	2,42	2,03	1,54	1,24
	$\eta_d$ (1400)	-	0,89	0,88	0,85	0,82	0,80	0,76	0,72	0,69	0,65	0,60	0,55
	$\eta_s$	-	0,71	0,68	0,61	0,57	0,53	0,46	0,42	0,38	0,35	0,29	0,26
090	Z1	-	4	3	2	2	2	1	1	1	1	1	1
	$\gamma$	-	29°11'	22°44'	15°36'	12°50'	10°54'	7°57'	6°30'	5°30'	4°46'	3°45'	3°06'
	Mx	-	4,84	4,84	4,84	3,69	2,98	4,84	3,69	2,98	2,5	1,89	1,52
	$\eta_d$ (1400)	-	0,9	0,89	0,86	0,84	0,82	0,78	0,75	0,72	0,69	0,63	0,59
	$\eta_s$	-	0,73	0,7	0,64	0,6	0,56	0,49	0,45	0,41	0,38	0,32	0,28
105	Z1	-	4	3	2	2	2	1	1	1	1	1	1
	$\gamma$	-	28°15'	21°57'	15°02'	14°41'	12°34'	7°39'	7°28'	6°22'	5°32'	4°24'	3°39'
	Mx	-	5,875	5,875	5,875	4,62	3,73	5,875	4,62	3,73	3,13	2,37	1,91
	$\eta_d$ (1400)	-	0,9	0,89	0,86	0,85	0,84	0,79	0,78	0,75	0,72	0,67	0,63
	$\eta_s$	-	0,72	0,69	0,63	0,62	0,59	0,48	0,48	0,44	0,41	0,36	0,32
110	Z1	-	4	3	2	2	2	1	1	1	1	1	1
	$\gamma$	-	28°15'	21°57'	15°02'	14°41'	12°34'	7°39'	7°28'	6°22'	5°32'	4°24'	3°39'
	Mx	-	5,875	5,875	5,875	4,62	3,73	5,875	4,62	3,73	3,13	2,37	1,91
	$\eta_d$ (1400)	-	0,9	0,89	0,86	0,85	0,84	0,79	0,78	0,75	0,72	0,67	0,63
	$\eta_s$	-	0,72	0,69	0,63	0,62	0,59	0,48	0,48	0,44	0,41	0,36	0,32
130	Z1	-	4	3	2	2	2	1	1	1	1	1	1
	$\gamma$	-	28°41'	22°19'	15°18'	13°52'	11°49'	7°47'	7°02'	5°58'	5°11'	4°07'	3°24'
	Mx	-	6,97	6,97	6,97	5,4	4,37	6,97	5,4	4,37	3,67	2,77	2,23
	$\eta_d$ (1400)	-	0,91	0,89	0,87	0,86	0,84	0,8	0,78	0,75	0,72	0,68	0,64
	$\eta_s$	-	0,72	0,69	0,63	0,61	0,58	0,49	0,46	0,43	0,39	0,34	0,3
150	Z1	-	6	4	3	2	2	2	1	1	1	1	1
	$\gamma$	-	32°09'	24°35'	17°27'	12°53'	11°19'	9°50'	6°32'	5°43'	4°57'	3°55'	3°14'
	Mx	-	5,5	6,155	5,5	6,155	5	4,193	6,155	5	4,193	3,17	2,55
	$\eta_d$ (1400)	-	0,91	0,9	0,88	0,86	0,84	0,83	0,78	0,76	0,73	0,68	0,64
	$\eta_s$	-	0,73	0,71	0,66	0,6	0,57	0,54	0,45	0,42	0,39	0,33	0,29

TR

DÖNÜŞ YÖNÜ

EN

DIRECTION OF ROTATION

DE

DREHSINN

IT

SENSO DI ROTAZIONE

FR

SENS DE ROTATION

ES

SENTIDO DE ROTACION

### PMRV - PRV



Vida sağ elle kullanım içindir.  
The helix is right-handed.  
Die Schnecke ist rechtsgängig.  
Il senso dell'elica è destro.  
Le sens d'hélice est à droite.  
El sentido de la hélice es hacia la derecha.

### PMRV+PMRV - PRV+PMRV

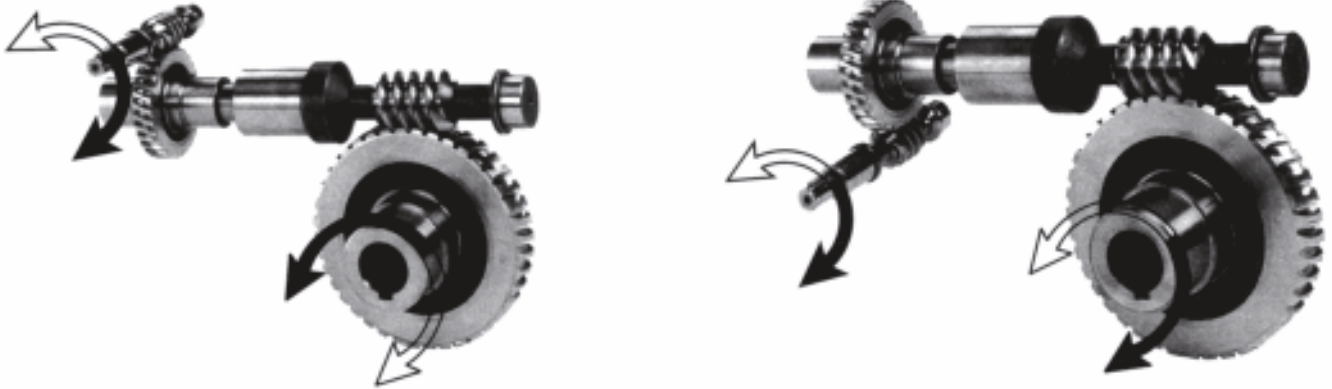

**TR TASARIM ÖZELLİKLERİ (PPC)**

PPC yapısı modüler niteliktedir ve herhangi tipte takılmış dişli motor (PAM) üzerine monte edilmek üzere ayrı bir takım olarak satılır. Bu bağlantıda flanş / çıkış şaftlarının değişik olasılıklarını sayfa 26'da görülebilir. Ana redüktörün üzerine ilk aşama helis kademeli modülünün monte edilmesi işlemi B14 tipi herhangi bir motor için kolaylıkla yapılabilir.

Ön helis kademe modülü tek başına kullanılamaz, takım sadece diğer bir akuplaj takımı ile birlikte kullanılabilir.

**Malzemeler**

Alüminyum alaşım gövde.

Dişliler sertleştirilmiş tavlanmış 20MnCr5 çelikten işlenmiş olup evolvent hassas bir şekilde taşlanmıştır.

**EN DESIGN FEATURES (PPC)**

The PPC construction is modular and therefore it can be supplied as a separate unit to mounted on any type fitted geared motor (PAM). In this connection, the various possibilities of flange/output shafts can be found on page 26. Fitting the pre-stage helical module on the main reduction unit is easily done as for any motor of type B14.

The pre-stage unit cannot be used by itself, but only coupled with another reduction unit.

**Materials**

Case in aluminium alloy.

Gears in case hardened, tempered steel 20MnCr5 (UNI7846) accurately ground on the involute.

**DE BAUEIGENSCHAFTEN (PPC)**

Die Bauweise der Übersetzungsvorstufe ist modular und kann daher als getrenntes Aggregat geliefert und auf einem Schneckengetriebe mit "PAM" Flansch montiert werden. Die unterschiedlichen Kombinationsmöglichkeiten von Flanschen/Wellen zeigt Seite 26. Die Montage der Vorstufe am Hauptgetriebe kann sehr einfach wie bei jedem Motor im Bauform B14 durchgeführt werden.

Die Vorstufe kann nicht einzeln, sondern nur zusammen mit einem anderen Getriebe eingesetzt werden.

**Werkstoffe**

Gehäuse aus Alulegierung.

Zahnräder aus Stahl 20MnCr5 (UNI7846), einsatzgehärtet und angelassen, Evoivente geschliffen.

**IT CARATTERISTICHE COSTRUTTIVE (PPC)**

La costruzione della precoppia è modulare e pertanto può essere fornita come gruppo separato da montare su qualsiasi tipo di motoriduttore predisposto (PAM). A tale proposito le varie possibilità di flange/alberi di uscita sono rilevabili a pag.26. Il montaggio della precoppia sul riduttore principale viene eseguito in maniera agevole come un qualsiasi motore in forma B14.

La precoppia non può essere utilizzata in maniera singola, ma solo accoppiata ad un altro riduttore.

**Materiali**

Cassa in lega alluminio.

Ingranaggi in acciaio 20MnCr5 (UNI7846) cementati, temprati, rinvenuti e accuratamente rettificati sull'evolvente.

**FR CARACTÉRISTIQUES DE CONSTRUCTION (PPC)**

La construction du pré couple est modulaire et il peut donc être livré comme groupe séparé à monter sur n'importe quel type de motoréducteur prédisposé (PAM). A cet égard, les différentes possibilités de brides/arbre de sortie sont mentionnées à la page 26. Le montage du pré couple sur le réducteur principal s'effectue très facilement, comme pour tout autre moteur de forme B14.

Le pré couple ne peut pas être utilisé tout seul, mais seulement accouplé à un autre réducteur.

**Matériaux**

Carcasse en alliage d'aluminium.

Engrenages en acier 20MnCr5 (UNI7846) cémentés, trempés, revenus et soigneusement rectifiés.

**ES CARACTERÍSTICAS DE CONSTRUCCIÓN (PPC)**

La construcción de la pre-reducción es modular y por lo tanto puede ser entregada como grupo separado de montar sobre cualquier tipo de motoreductor predisposto (PAM). Las distintas posibilidades de bridas/ejes de salida son indicadas en la página 26. El montaje de la pre-reducción sobre el reductor principal se efectúa muy facilmente, como para cualquier motor de forma B14.

El pre-reductor no puede ser utilizado directamente como reductor, solo puede ir acoplado a otro reductor.

**Materiales**

Caja de aleación de aluminio.

Engranajes de acero 20MnCr5 (UNI7846) cementados, templados, revenidos y cuidadosamente rectificado sobre la evolvente.

**TR ELEKTRİK MOTORUNA YAPILAN AKUPLAJ**

Giriş dişlisinin doğru bir şekilde elektrik motor şaftının üzerine oturtulması aşağıdaki talimatları uygulamanızı gerektirir.

- Elektrik motor şaftını boydan boya temizleyin.
  - Motor kamasını yuvasından çıkartın.
  - Burcu (1) giriş şaftına şekilde gösterildiği gibi tutturun. Bu işi kolaylaştırmak için burcu 70/80°C'ye kadar ısıtın.
  - Yerinden çıkartılmış olduğunuz eski kamanın yerine daha önceden verilmiş olan yenisini (3) takın.
  - Pinyon (c) maddesinde anlatılan önlemleri aralık yerleştirin.
  - Rondelayı (5) yerleştirip vida (6) ile sıkın.
  - Yağ keçesinin önünde bulunan yağ kapağını, indirgeyici gövdenin önceden yağlanmış olduğunu göz önünde tutarak çıkartın.
  - Yağ keçesini yerleştiriniz ve daha sonra motor montajlanırken keçe dudaklarına zarar gelmemesine dikkat ediniz.
- NOT: Doğru işlem yapmak için, yani gürültü veya titreşim olmadan çalıştırmak için iyi kalitede motor kullanmanız tavsiye edilir.

**EN COUPLING TO ELECTRIC MOTOR**

Correctly fitting the pinion on the electric motor shaft requires you keep to the following instructions:

- Thoroughly clean the electric motor shaft.
  - Remove the motor key from its seat.
  - Fit the bush (1) to the drive shaft as shown in the diagram. To make this easier, you can heat the bush to approximately 70/80°C.
  - Fit the new key (3) provided in place of the one removed beforehand.
  - Fit the pinion (4) taking the same precautions as described in point (c).
  - Fit the washer (5) and tighten with the screw (6).
  - Remove the rubber cap mounted on the seat of the oil seal, taking care since the pre-stage unit is already complete with lubricant.
  - Fit the oil seal (2) and then the motor assembly, taking care not to damage the lip of the oil seal.
- N.B: For correct operation, with no vibration or noise, it is recommended to use good quality motors.

**DE MONTAGE DES ELEKTROMOTORS**

Für eine einwandfreie montage des ritzels auf der welle des elektromotors sind nachstehende anweisungen zu beachten:

- Welle des elektromotors sorgfältig reinigen.
  - Motorseitige Paßfeder abnehmen.
  - Buchse (1) auf die motorwelle nach schema aufziehen, ggf. Hierzu buchse auf ca. 70/80°C erwärmen und aufschumpfen.
  - Neue Paßfeder (3) anstelle der ursprünglichen einsetzen.
  - Ritzel (4) montieren (ggf. erwärmen).
  - Scheibe (5) aufsetzen und mit Schraube (6) festziehen.
  - Gummi-Verschlusskappe am sitz des dichtrings vorsichtig entfernen, da die vorstufe mit schmieröl gefüllt ist (Öffnung nach oben).
  - Dichtring (2) und motor montieren; dabei ist darauf zu achten, daß die lippe des dichtrings nicht beschädigt wird.
- Anmerkung: Für eine schwingungsfreie und geräuscharme funktion sollten motoren mindestens mit toleranzen nach DIN 42955N eingesetzt werden.

**IT MONTAGGIO MOTORE ELETTRICO**

Per il corretto montaggio del pignone sull'albero del motore elettrico occorre attenersi alle seguenti istruzioni:

- Pulire accuratamente l'albero del motore elettrico.
  - Togliere la linguetta del motore dalla sede.
  - Montare la boccola (1) sull'albero motore secondo l'orientamento indicato nello schema. Per facilitare il montaggio si può riscaldare la boccola a circa 70/80°C.
  - Montare la nuova linguetta (3) fornita a corredo al posto di quella precedentemente tolta.
  - Montare il pignone (4) adottando gli stessi accorgimenti descritti al punto (c).
  - Montare la rondella (5) e serrare tramite la vite (6).
  - Togliere il tappo di chiusura in gomma montato sulla sede dell'anello di tenuta, facendo attenzione in quanto il gruppo precoppia è già completo di lubrificante.
  - Montare l'anello di tenuta (2) e quindi il gruppo motore curando l'inserimento affinché non si danneggi il labbro dell'anello di tenuta.
- N.B. Per un corretto funzionamento, esente de vibrazioni e rumorosità si consiglia di adottare motori di buona qualità.

**FR MONTAGE DU MOTEUR ÉLECTRIQUE**

Pour le montage correct du pignon sur l'arbre du moteur électrique, il faut respecter les instructions suivantes:

- Nettoyer soigneusement l'arbre du moteur électrique.
  - Enlever la clavette du moteur de son siège.
  - Monter la douille (1) sur l'arbre-moteur suivant l'orientation indiquée dans le schéma. Pour faciliter le montage, on peut chauffer la douille à environ 70/80°C.
  - Monter la nouvelle clavette (3) au lieu de celle précédemment enlevée.
  - Monter le pignon (4) en adoptant les mesures indiquées au point (c).
  - Monter la rondelle (5) et serrer à l'aide de la vis (6).
  - Enlever le bouchon en caoutchouc monté sur le siège de la bague d'étanchéité, en faisant attention, car le groupe précouple contient du lubrifiant.
  - Monter la bague d'étanchéité (2) et ensuite le groupe moteur avec beaucoup de soin, pour ne pas endommager la lèvre de la bague d'étanchéité.
- NOTE: Pour un fonctionnement correct, sans vibrations et bruits, on conseille d'utiliser des moteurs de bonne qualité.

**ES MONTAJE MOTOR ELECTRICO**

Para el correcto montaje del piñon sobre el eje del motor eléctrico, es necesario respetar las siguientes instrucciones:

- Limpiar con cuidado el eje del motor eléctrico.
  - Sacar la chaveta del motor.
  - Montar el casquillo (1) sobre el eje motor según la orientación indicada en el esquema. Para facilitar el montaje, se puede calentar el casquillo a aprox 70/80°C.
  - Montar la nueva chaveta (3) entregada en lugar de la anteriormente sacada.
  - Montar el piñon (4) adoptando las mismas precauciones indicadas al punto (c).
  - Montar la arandela (5) y apretar con el tornillo (6).
  - Sacar con cuidado el tapón de cierre de goma montado en el asiento del anillo de retén, porque el pre-reductor par está equipado de lubricante.
  - Montar el retén (2) y luego el grupo motor con mucho cuidado para no dañar el labio del retén.
- NOTA: Para un correcto funcionamiento sin vibraciones ni ruidos, se aconseja montar motores de buena calidad.

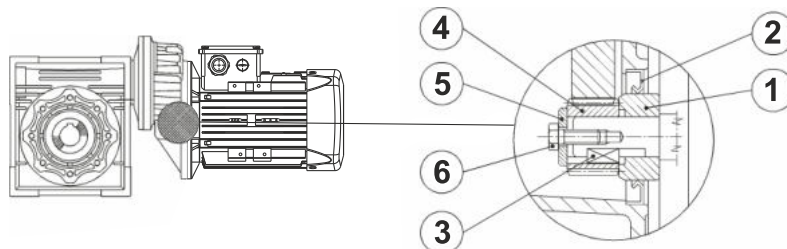

TR MONTAJ POZİSYONU

EN MOUNTING POSITIONS

DE EINBAULAGE

IT PIAZZAMENTO

FR POS. DE MONTAGE

ES POS. DE MONTAJE

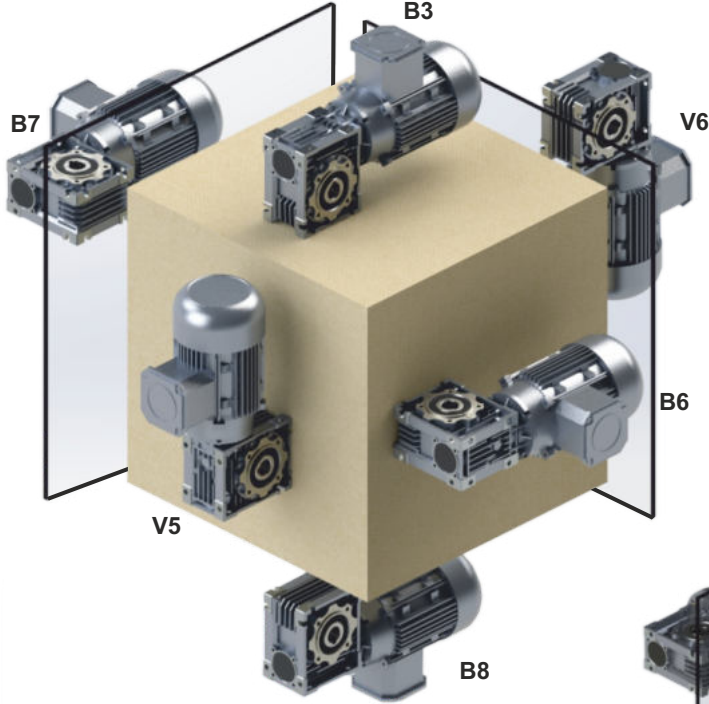
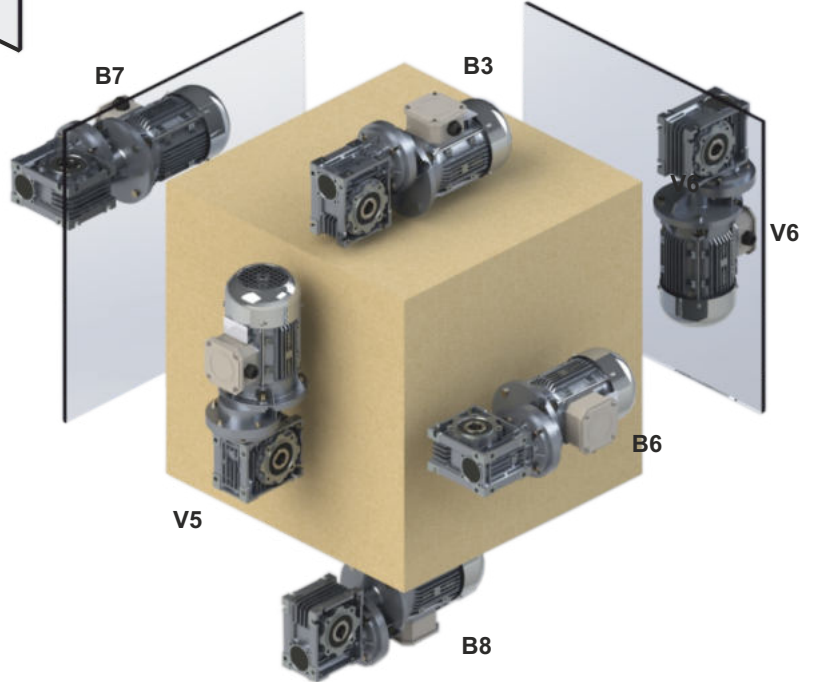
**PMRV - PRV**

**PPC - PMRV**

- "U" versiyonu 030 - 075 arası gövdeler için geçerlidir. Bu tipte ölçüler için montaj pozisyonu belirtmek gerekmez.
- Dikey pozisyonlar için, 6-7. sayfalarda verilen bilgileri kontrol ediniz.
- Herhangi bir seçenek sunulmazsa standart pozisyonumuz B3'tür.
- Farklı pozisyon belirtildiği takdirde, Teknik Servisimize başvurmanız gerekmektedir.

- "U" version is related to sizes from 030 to 075. For these sizes it is not necessary to specify mounting position.
- For vertical positions, check with pages 6-7.
- Unless specified otherwise, the standard positions are B3.
- For positions not envisaged, it is necessary to call our Technical Service.

- Die Ausführung "U" bezieht sich auf die Baugröße von 030 bis 075. Für diesen Baugrößen ist die Angabe der einbaulage nicht erforderlich zu spezifizieren.
- Für die vertikalen einbaulagen siehe seite 6-7.
- Falls nicht anders angegeben, sind B3 die standardeinbaulagen.
- Für nicht angegebene einbaulagen setzen sie sich bitte mit unserem kundendienst in verbindung.

- La versione "U" è relativa alle gr. 030 - 075. Per queste grandezze non è necessario specificare la posizione di piazzamento.
- Per le posizioni di piazzamento verticali verificare quanto detto a pag.10-11.
- Se non diversamente specificato le posizioni standard sono B3.
- Per le posizioni di piazzamento non previste occorre rivolgersi al ns. Servizio tecnico.

- La version "U" se réfère aux tailles de 030 à 075. Pour ces tailles il n'est pas nécessaire d'indiquer la position de montage.
- Pour les positions de montage verticales, voir pages 6 et 7.
- Si non spécifié, les positions standard sont B3.
- Pour les positions de montage non prévues, contacter notre S.se technique.

- La version "U" se refiere a los tamanos de 030 hasta 075. Para estos tamaño no es necesario especificar la posición de montaje.
- Para las posiciones de montaje verticales, ver las páginas 6-7.
- Si non se especifica el contrario, las posiciones estándar son B3.
- Para las posiciones de montaje no previstas, es necesario ponerse en contacto con nuestro Servicio técnico.

TR UYGULAMA  
IT ESECUZIONE

EN EXECUTION  
FR EXÉCUTION

DE PAARUNGSFORM  
ES EJECUCIÓN

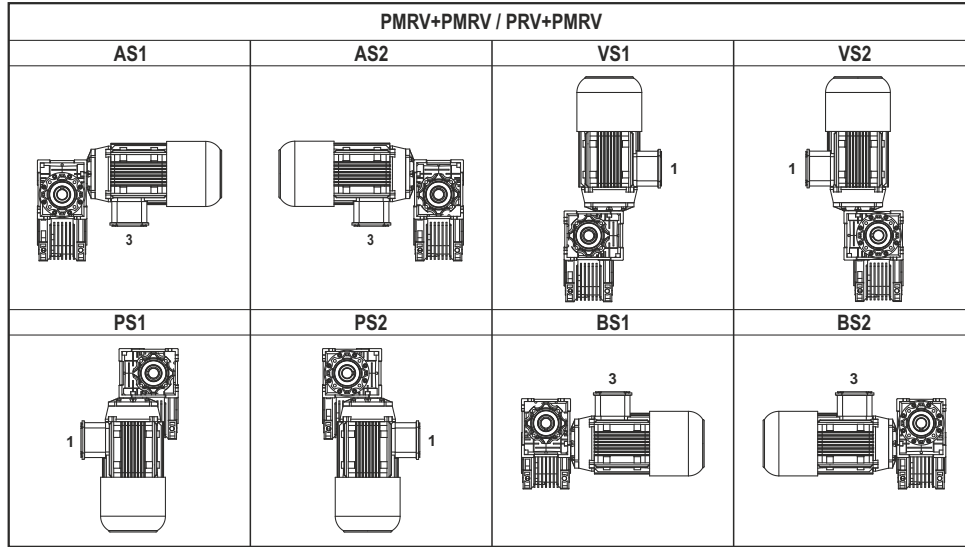

1. redüktörün 2. redüktöre göre montaj pozisyonu versiyona bağlıdır. Sipariş sırasında aksi bir şey talep edilmediği takdirde kombinasyon grupları BS2 de verilmiştir. 2. redüktör için belirtilen montaj pozisyonları sunulmuştur. Olası montaj pozisyonları için sayfa 34'e bakınız.

L'esecuzione determina la posizione di montaggio del 1° riduttore rispetto al 2° riduttore. Se non diversamente specificato in fase d'ordine il gruppo viene fornito in esecuzione BS2. La posizione di piazzamento va riferita al 2° riduttore, per le posizioni previste vedere a pag.34.

The position of the 1st reducer with respect to the 2nd gear reducer depend on the version. Unless otherwise specified at the time of order, combination groups are supplied in version BS2. The specified mounting position refers to the 2nd gear reducer. See page 34 for the possible mounting positions.

L'exécution détermine la position de montage du premier réducteur par rapport au second. Sauf indication contraire à la commande, l'ensemble est livré ex exécution BS2. La position de montage se rapporte au deuxième réducteur: pour les positions prévues, voir page 34.

Die paarungsform legt die einbauanordnung des 1. getriebe fest. Sofern nicht speziell in der bestellbezeichnung angeführt, wird das getriebe in BS2 form geliefert. Die baufom bezieht sich auf das 2. getriebe, siehe seite 34 die verschiedenen möglichkeiten.

La ejecucción determina la posición de montaje del primer reductor respecto del segundo. Salvo diversas especificaciones requeridas en el pedido, el grupo es suministrado en ejecución BS2. La posición de instalación se refiere al segundo reductor: en relación a las posiciones previstas ver pág. 34.

#### F-FL Flanşı / Flange F-FL / Flansch F-FL / Flangia F-FL / Flasque F-FL / Flasque-bride F-FL

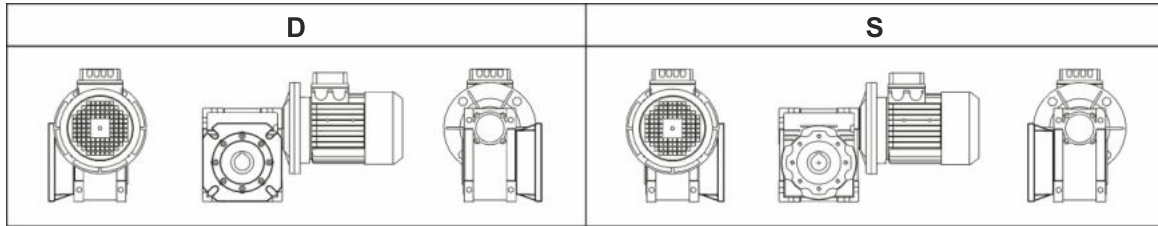

- Aksi yönde bir bildirim olmadığı takdirde yavaşlatma takımı B3 pozisyonunda olduğu gibi D pozisyonunda tedarik edilir.
- Unless specified otherwise, the reduction unit is supplied with the flange in pos. D referred to position B3.
- Falls nicht anders vereinbart, wird das getriebe mit flansch in position D, auf die B3-einbaulage bezogen, geliefert.
- Se non diversamente specificato il riduttore viene fornito con flangia in pos. D riferito alla posizione di piazzamento B3.
- Si non différemment spécifié, le réducteur est livré avec bride en pos. D correspondant à la position de montage B3.
- Si no diversamente especificado, el reductor se entrega con brida en pos. D, relacionado a la posición de montaje B3.

#### Terminal kutusunun pozisyonu / Pos. of terminal box / Klemmenkastenlage / Pos. morsettieria / Pos. du bornier / Pos. caja de bornes

- Sipariş sırasında özel istekleriniz olacaksa şekilde gösterildiği üzere terminal kutusunun pozisyonunu belirtiniz.
- In the case of specific requirements, when ordering, specify the position of the terminal box as shown in the diagram.
- Im falle von sonderanforderungen ist bei auftragserteilung die lage des klemmenkastens gemäß dem schema genau anzugeben.
- Nel caso di particolari esigenze specificare in fase di ordine la posizione della morsetteria come da schema.
- En cas d'exigences particulières, spécifier, lors de la commande, la position du bornier comme d'après le schéma.
- En caso de exigencias particulares, detallar en el pedido, la posición de la caja de bornes según el esquema.

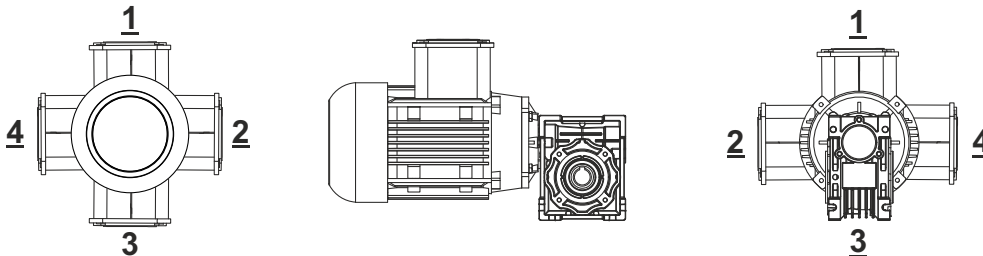



A large area of the page is filled with horizontal dotted lines, providing a template for writing or drawing.



## Motorlu Seçim Tabloları

Selection Tables of  
Gearedmotors

Auswahltabellen der  
Getriebemotoren

Tabelle di selezione dei  
motoriduttori

Tables de Gearedmotors de  
sélection

Tablas de selección de  
gearedmotors

**PMRV**  
**030...150**

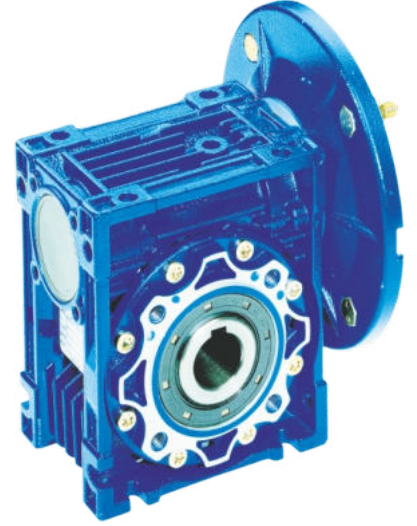

**PRV**  
**030...150**



**PMRV / PRV**

TR TEKNİK TANIMLAR

EN TECHNICAL DESCRIPTIONS

DE TECHNISCHE BESCHREIBUNGEN

IT DESCRIZIONI TECNICHE

FR DESCRIPTIONS TECHNIQUES

ES DESCRIPCIONES TECNICAS

**Motorlu redüktör performans tablolarının yapısı**

Notify about performance tables for Geared motor.

Mitteilung über Leistungstafeln für Getriebemotor

Notificare sulle tabelle di performance per i motoriduttori

Aviser sur les tableaux de performance pour le motoréducteur

Notificar sobre la tabla de performance para los motoreductores.

**0.37 kW** →**Redüktör motor gücü**Gear unit motor power  
Potenza motore riduttore  
Potencia del motor del reductor  
Réducteur puissance du moteur  
Getriebe Motorleistung**Motor gücü**Rated motor power  
Motormennleistung  
Potenza nominale del motore  
Puissance nominale du moteur  
Potencia nominal del motor**Servis faktörü**Service factor  
Factor de servicio  
Fattore di servizio  
Facteur de service  
Servicefaktor**Tahvil oranı**Reduction ratio  
Untersetzungsverhältnis  
Rapporto di riduzione  
Rapport de réduction  
Relación de reducción

P <sub>1</sub> [kW]	n <sub>2</sub> [Min <sup>-1</sup> ]	M <sub>2</sub> [Nm]	f <sub>B</sub>	i <sub>ges</sub>	FR [N]	Tip / Type / Typ Tipo / Type / Tipo	 mm
<b>0.18</b>	560.0	2.7	4.4	5	474	<b>PMRV030 - 63M/2A</b>	72
	373.3	4.0	3.2	7.5	542		
	280.0	5.2	2.5	10	597		
	186.7	7.5	1.7	15	683		
	140.0	10	1.3	20	752		
	112.0	11	1.4	25	810		
	93.3	13	1.1	30	861		
	70.0	16	0.9	40	948		

**Çıkış devri**  
Output speed  
Abtriebsdrehzahl  
Vitesse de sortie  
Velocità di uscita  
Velocidad de salida

**Çıkış momenti**  
Output torque  
Abtriebsdrehmoment  
Coppia di uscita  
Par de salida  
Couple de sortie

**Müsaade edilebilir radyal yükler**  
Permissible radial force  
Zulässige Radialkraft  
Force radiale admissible  
Fuerza radial admisible  
Forza radiale ammessa

**Redüktör tipi**  
Gear unit motor type  
Getriebe Motortyp  
Réducteur type de moteur  
Reductor tipo de motor  
Riduttore tipo di motore

**Ölçü sayfaları**  
Drawing page  
Zeichenblatt  
La page de dessin  
Página de dibujo  
Zeichenblatt

P <sub>1</sub> [kW]	n <sub>2</sub> [Min <sup>-1</sup> ]	M <sub>2</sub> [Nm]	f <sub>B</sub>	i <sub>ges</sub>	F <sub>R</sub> [N]	Tip / Type / Typ Tipo / Type / Tipo	 mm
<b>0.06</b>	280.0	1.8	10.1	5	597	<b>PMRV030 - 564A</b>	72
	186.7	2.6	6.9	7.5	683		
	140.0	3.4	5.4	10	752		
	93.3	4.7	3.8	15	861		
	70.0	6.0	3.0	20	948		
	56.0	7.0	3.0	25	1021		
	46.7	8.0	2.5	30	1085		
	35.0	9.7	1.9	40	1194		
	28.0	11	1.5	50	1286		
	23.3	13	1.3	60	1367		
17.5	14	0.9	80	1504			
15.0	18	0.9	60	1583	<b>PMRV030 - 56B6</b>	72	
18.0	18	2.3	50	2868	<b>PMRV040 - 56B6</b>	73	
15.0	21	1.9	60	3047			
11.3	24	1.4	80	3354			
9.0	27	1.2	100	3490			
4.7	57	1.3	300	3490	<b>PMRV030/040 - 564A</b>	87	
3.5	70	0.9	400	3490			
2.8	96	0.6	500	3490			
2.3	104	0.7	600	3490			
1.9	121	0.6	750	3490			
1.6	139	0.5	900	3490			
1.2	166	0.4	1200	3490			
0.9	196	0.4	1500	3490			
0.8	218	0.3	1800	3490			
0.58	261	0.2	2400	3490			
0.4	300	0.2	3200	3490			
0.4	279	0.1	4000	3490			
0.28	338	0.1	5000	3490			
1.6	141	1.0	900	4840	<b>PMRV030/050 - 564A</b>	87	
1.2	169	0.7	1200	4840			
0.93	199	0.7	1500	4840			
0.78	222	0.7	1800	4840			
0.6	266	0.5	2400	4840			
0.5	307	0.4	3000	4840			
0.35	288	0.3	4000	4840			
0.29	311	0.3	4800	4840			
0.9	204	1.1	1500	6270	<b>PMRV030/063 - 564A</b>	88	
0.78	225	0.9	1800	6270			
0.58	276	0.8	2400	6270			
0.47	319	0.7	3000	6270			
0.35	306	0.6	4000	6270			
0.28	360	0.4	5000	6270			
0.6	330	1.1	2400	7380	<b>PMRV040/075 - 564A</b>	88	
0.47	377	0.8	3000	7380			
0.35	355	0.7	4000	7380			
0.28	419	0.5	5000	7380			
0.5	406	1.4	3000	8180	<b>PMRV040/090 - 564A</b>	88	
0.35	365	1.3	4000	8180			
0.28	431	1.0	5000	8180			

P <sub>1</sub> [kW]	n <sub>2</sub> [Min <sup>-1</sup> ]	M <sub>2</sub> [Nm]	f <sub>B</sub>	i <sub>ges</sub>	F <sub>R</sub> [N]	Tip / Type / Typ Tipo / Type / Tipo	 mm
<b>0.09</b>	560.0	1.4	8.8	5	474	<b>PMRV030 - 562A</b>	72
	373.3	2.0	6.5	7.5	542		
	280.0	2.6	5.0	10	597		
	186.7	3.7	3.5	15	683		
	140.0	4.8	2.5	20	752		
	112.0	5.7	2.8	25	810		
	93.3	6.5	2.3	30	861		
	70.0	8.1	1.7	40	948		
	56.0	10	1.4	50	1021		
	46.7	11	1.1	60	1085		
35.0	13	0.9	80	1194			
	280.0	2.7	6.7	5	597	<b>PMRV030 - 564B</b>	72
	186.7	3.9	4.6	7.5	683		
	140.0	5.0	3.6	10	752		
	93.3	7.1	2.5	15	861		
	70.0	9.0	2.0	20	948		
	56.0	10	2.0	25	1021		
	46.7	12	1.7	30	1085		
	35.0	14	1.2	40	1194		
	28.0	17	1.0	50	1286		
	23.3	19	0.9	60	1367		
	180.0	4.1	4.9	5	692	<b>PMRV030 - 63A6</b>	72
	120.0	5.9	3.4	7.5	792		
	90.0	7.6	2.6	10	871		
	60.0	11	1.9	15	997		
	45.0	13	1.5	20	1098		
	36.0	15	1.5	25	1183		
	30.0	17	1.2	30	1257		
	22.5	21	1.0	40	1383		
18.0	24	0.7	50	1490			
	28.0	19	2.0	50	2475	<b>PMRV040 - 564B</b>	73
	23.3	21	1.7	60	2630		
	17.5	26	1.3	80	2895		
	14.0	29	1.0	100	3118		
	30.0	19	2.6	30	2419	<b>PMRV040 - 63A6</b>	73
	22.5	24	1.9	40	2662		
	18.0	27	1.5	50	2868		
	15.0	31	1.3	60	3047		
	11.3	37	1.0	80	3354		
	9.0	41	0.8	100	3490		
	12.0	47	1.3	75	3283	<b>PPC063/PMRV040 - 63A6</b>	82
	10.0	51	1.4	90	3488		
	7.5	62	1.1	120	3490		
	6.0	72	0.8	150	3490		
	5.0	79	0.7	180	3490		
4.7	88	0.8	300	3490	<b>PMRV030/040 - 564B</b>	87	
	15.0	32	2.3	60	4183	<b>PMRV050 - 63A6</b>	74
	11.3	37	1.8	80	4604		
	9.0	42	1.3	100	4840		
	6.0	73	1.6	150	4840	<b>PPC063/PMRV050 - 63A6</b>	82
	5.0	81	1.3	180	4840		
	3.8	94	0.9	240	4840		
	3.0	106	0.7	300	4840		

P <sub>1</sub> [kW]	n <sub>2</sub> [Min <sup>-1</sup> ]	M <sub>2</sub> [Nm]	f <sub>B</sub>	i <sub>ges</sub>	F <sub>R</sub> [N]	Tip / Type / Typ Tipo / Type / Tipo	 mm
0.09	3.5	107	1.2	400	4840	PMRV030/050 - 564B	87
	2.8	123	1.0	500	4840		
	2.3	159	0.9	600	4840		
	1.9	185	0.8	750	4840		
	1.6	212	0.7	900	4840		
	3.8	99	1.7	240	6270	PPC063/PMRV063 - 63A6	83
	3.0	109	1.4	300	6270		
	1.6	200	1.0	900	6270	PMRV030/063 - 564B	88
	1.2	263	0.9	1200	6270		
	0.93	305	0.7	1500	6270		
	0.9	360	1.1	1500	7380	PMRV040/075 - 564B	88
	0.78	404	1.0	1800	7380		
	0.58	496	0.7	2400	7380		
	0.5	609	0.9	3000	8180	PMRV040/090 - 564B	88
	0.35	548	0.8	4000	8180		
0.12	280.0	3.6	5.1	5	597	PMRV030 - 63M/4A	72
	186.7	5.2	3.4	7.5	683		
	140.0	6.7	2.7	10	752		
	93.3	9.5	1.9	15	861		
	70.0	12	1.5	20	948		
	56.0	14	1.5	25	1021		
	46.7	16	1.3	30	1085		
	35.0	19	0.9	40	1194		
	28.0	23	0.8	50	1286		
	180.0	5.4	3.7	5	692		
	120.0	7.9	2.5	7.5	792		
	90.0	10	2.0	10	871		
	60.0	14	1.4	15	997		
	45.0	18	1.1	20	1098		
	36.0	20	1.1	25	1183		
	30.0	23	0.9	30	1257		
	46.7	17	2.6	30	2087	PMRV040 - 63M/4A	73
	35.0	21	1.9	40	2298		
	28.0	25	1.5	50	2475		
	23.3	28	1.3	60	2630		
	17.5	34	1.0	80	2895		
	14.0	38	0.8	100	3118		
	30.0	25	1.9	30	2419	PMRV040 - 63M/6	73
	22.5	32	1.4	40	2662		
	18.0	36	1.2	50	2868		
	15.0	41	0.9	60	3047		
	18.7	42	1.2	75	2833	PPC063/PMRV040 - 63M/4A	82
	15.6	46	1.2	90	3011		
	11.7	57	0.9	120	3314		
	9.3	66	0.7	150	3490		
	7.8	74	0.6	180	3490		
	12.0	62	1.0	75	3283	PPC063/PMRV040 - 63M/6	82
	10.0	68	1.1	90	3488		
	7.5	83	0.8	120	3490		
	23.3	29	2.3	60	3610	PMRV050 - 63M/4A	74
	17.5	35	1.9	80	3973		
14.0	40	1.4	100	4280			

P <sub>1</sub> [kW]	n <sub>2</sub> [Min <sup>-1</sup> ]	M <sub>2</sub> [Nm]	f <sub>B</sub>	i <sub>ges</sub>	FR [N]	Tip / Type / Typ Tipo / Type / Tipo	 mm
<b>0.12</b>	22.5	32	2.6	40	3654	<b>PMRV050 - 63M/6</b>	74
	18.0	38	2.0	50	3936		
	15.0	42	1.7	60	4183		
	11.3	50	1.4	80	4604		
	9.0	56	1.0	100	4840		
	9.3	68	1.3	150	4840	<b>PPC063/PMRV050 - 63M/4A</b>	82
	7.8	75	1.1	180	4840		
	5.8	88	0.8	240	4840		
	4.7	98	0.7	300	4840		
	12.0	63	1.7	75	4506	<b>PPC063/PMRV050 - 63M/6</b>	82
	10.0	70	2.1	90	4788		
	7.5	84	1.5	120	4840		
	6.0	97	1.2	150	4840		
	5.0	108	1.0	180	4840		
	3.8	125	0.7	240	4840		
	4.7	119	1.2	300	4840	<b>PMRV030/050 - 63M/4A</b>	87
	3.5	142	0.9	400	4840		
	2.8	164	0.7	500	4840		
	5.8	92	1.5	240	6270	<b>PPC063/PMRV063 - 63M/4A</b>	83
	4.7	103	1.2	300	6270		
	6.0	101	2.1	150	6270	<b>PPC063/PMRV063 - 63M/6</b>	83
	5.0	112	1.8	180	6270		
	3.8	131	1.3	240	6270		
	3.0	145	1.0	300	6270		
2.8	171	1.3	500	6270			
2.3	208	1.1	600	6270	<b>PMRV030/063 - 63M/4A</b>	88	
1.9	241	0.9	750	6270			
1.6	325	1.2	900	7380			
1.2	399	0.9	1200	7380	<b>PMRV040/075 - 63M/4A</b>	88	
0.8	547	0.9	1800	8180	<b>PMRV040/090 - 63M/4A</b>	88	
0.58	695	0.9	2400	8180			
0.5	884	1.1	3000	10320	<b>PMRV050/105 - 63M/4A</b>	89	
0.35	784	1.0	4000	10320			
0.28	928	0.76	5000	10320			
0.5	884	1.2	3000	10320	<b>PMRV050/110 - 63M/4A</b>	89	
0.35	784	1.0	4000	10320			
0.28	928	0.8	5000	10320			
<b>0.15</b>	180.0	7	3.0	5	692	<b>PMRV030 - 63C6</b>	72
	120.0	10	2.0	7.5	792		
	90.0	13	1.6	10	871		
	60.0	18	1.1	15	997		
	45.0	22	0.9	20	1098		
	60.0	19	2.4	15	1920	<b>PMRV040 - 63C6</b>	73
	45.0	24	1.8	20	2113		
	36.0	29	1.5	25	2276		
	30.0	32	1.6	30	2419		
	22.5	39	1.1	40	2662		
	18.0	45	0.9	50	2868		
	18.0	47	1.6	50	3936	<b>PMRV050 - 63C6</b>	74
	15.0	53	1.4	60	4183		
	11.3	62	1.1	80	4604		
	10.0	87	1.7	90	4788	<b>PPC063/PMRV050 - 63C6</b>	82
	7.5	105	1.2	120	4840		
	6.0	127	1.7	150	6270	<b>PPC063/PMRV063 - 63C6</b>	83
	5.0	140	1.4	180	6270		

P <sub>1</sub> [kW]	n <sub>2</sub> [Min <sup>-1</sup> ]	M <sub>2</sub> [Nm]	f <sub>B</sub>	i <sub>ges</sub>	F <sub>R</sub> [N]	Tip / Type / Typ Tipo / Type / Tipo	 mm
0.18	560.0	2.7	4.4	5	474	PMRV030 - 63M/2A	72
	373.3	4.0	3.2	7.5	542		
	280.0	5.2	2.5	10	597		
	186.7	7.5	1.7	15	683		
	140.0	10	1.3	20	752		
	112.0	11	1.4	25	810		
	93.3	13	1.1	30	861		
	70.0	16	0.9	40	948		
	280.0	5.3	3.4	5	597	PMRV030 - 63M/4B	72
	186.7	7.8	2.3	7.5	683		
	140.0	10	1.8	10	752		
	93.3	14	1.3	15	861		
	70.0	18	1.0	20	948		
	56.0	21	1.0	25	1021		
	46.7	24	0.8	30	1085		
	93.3	14	2.4	30	1657	PMRV040 - 63M/2A	73
	70.0	18	1.8	40	1824		
	56.0	21	1.4	50	1964		
	70.0	19	2.0	20	1824	PMRV040 - 63M/4B	73
	56.0	23	1.7	25	1964		
	46.7	26	1.7	30	2087		
	35.0	32	1.3	40	2298		
	28.0	38	1.0	50	2475		
	23.3	43	0.8	60	2630		
	45.0	29	1.5	20	2113	PMRV040 - 71M/6A	73
	36.0	34	1.3	25	2276		
	30.0	38	1.3	30	2419		
	22.5	47	1.0	40	2662		
	18.7	64	0.8	75	2833	PPC063/PMRV040 - 63M/4B	82
	15.6	70	0.8	90	3011		
	11.7	85	0.6	120	3314		
	46.7	24	2.1	60	2865	PMRV050 - 63M/2A	74
	35.0	30	1.5	80	3153		
	28.0	34	1.2	100	3397		
	35.0	33	2.3	40	3153	PMRV050 - 63M/4B	74
	28.0	39	1.9	50	3397		
23.3	43	1.6	60	3610			
17.5	52	1.2	80	3973			
14.0	60	0.9	100	4280			
18.0	56	1.4	50	3936	PMRV050 - 71M/6A	74	
15.0	63	1.1	60	4183			
11.3	75	0.9	80	4604			
18.7	64	1.4	75	3889	PPC063/PMRV050 - 63M/4B	82	
15.6	71	1.5	90	4132			
11.7	87	1.1	120	4548			
9.3	101	0.9	150	4840			
7.8	113	0.7	180	4840			
5.8	133	0.6	240	4840			
12.0	95	1.2	75	4506	PPC071/PMRV050 - 71M/6A	83	
10.0	105	1.4	90	4788			
7.5	126	1.0	120	4840			
15.0	66	2.1	60	5467	PMRV063 - 71M/6A	75	
11.3	79	1.6	80	6018			
9.0	90	1.4	100	6270			

P <sub>1</sub> [kW]	n <sub>2</sub> [Min <sup>-1</sup> ]	M <sub>2</sub> [Nm]	f <sub>B</sub>	i <sub>ges</sub>	F <sub>R</sub> [N]	Tip / Type / Typ Tipo / Type / Tipo	 mm
0.18	9.3	103	1.7	150	6270	PPC063/PMRV063 - 63M/4B	83
	7.8	117	1.4	180	6270		
	5.8	139	1.0	240	6270		
	4.7	155	0.8	300	6270		
	12.0	97	2.2	75	5889	PPC071/PMRV063 - 71M/6A	83
	10.0	107	2.4	90	6259		
	7.5	131	1.8	120	6270		
	6.0	152	1.4	150	6270		
	5.0	168	1.2	180	6270		
	3.8	197	0.9	240	6270		
	3.0	218	0.7	300	6270		
	3.5	222	1.0	400	6270	PMRV030/063 - 63M/4B	88
	2.8	257	0.8	500	6270		
	5.0	179	1.7	180	7380	PPC071/PMRV075 - 71M/6A	84
	3.8	211	1.2	240	7380		
	3.0	235	1.0	300	7380		
2.3	362	1.1	600	7380	PMRV040/075 - 63M/4B	88	
1.9	435	0.9	750	7380			
1.6	487	0.8	900	7380			
1.2	629	1.0	1200	8180	PMRV040/090 - 63M/4B	88	
0.93	735	0.8	1500	8180			
0.8	861	1.3	1800	10320	PMRV050/105 - 63M/4B	89	
0.58	1113	0.9	2400	10320			
0.8	861	1.5	1800	10320	PMRV050/110 - 63M/4B	89	
0.58	1113	1.1	2400	10320			
0.22	280.0	7	2.8	5	597	PMRV030 - 63C4	72
	186.7	10	1.9	7.5	683		
	140.0	12	1.5	10	752		
	93.3	17	1.0	15	861		
	70.0	22	0.8	20	948		
	93.3	18	2.2	15	1657	PMRV040 - 63C4	73
	70.0	23	1.7	20	1824		
	56.0	28	1.4	25	1964		
	46.7	32	1.4	30	2087		
	35.0	39	1.1	40	2298		
	28.0	47	0.8	50	2475		
	28.0	47	1.5	50	3397	PMRV050 - 63C4	74
	23.3	53	1.3	60	3610		
	17.5	64	1.0	80	3973		
	18.7	78	1.2	75	3889	PPC063/PMRV050 - 63C4	82
	15.6	86	1.2	90	4132		
11.7	106	0.9	120	4548			
9.3	126	1.4	150	6270	PPC063/PMRV063 - 63C4	83	
7.8	143	1.1	180	6270			
4.7	210	1.1	300	6270	PMRV030/063 - 63C4	88	
3.5	271	0.8	400	6270			
0.25	560.0	3.8	3.2	5	474	PMRV030 - 63M/2B	72
	373.3	5.6	2.3	7.5	542		
	280.0	7.2	1.8	10	597		
	186.7	10	1.3	15	683		
	140.0	13	0.9	20	752		
	112.0	16	1.0	25	810		
	93.3	18	0.8	30	861		





P <sub>1</sub> [kW]	n <sub>2</sub> [Min <sup>-1</sup> ]	M <sub>2</sub> [Nm]	f <sub>B</sub>	i <sub>ges</sub>	FR [N]	Tip / Type / Typ Tipo / Type / Tipo	 mm		
0.25	280.0	8	4.5	5	1149	PMRV040 - 71M/4A	73		
	186.7	11	3.6	7.5	1315				
	140.0	14	2.8	10	1447				
	93.3	21	1.9	15	1657				
	70.0	27	1.5	20	1824				
	56.0	32	1.2	25	1964				
	46.7	36	1.3	30	2087				
	35.0	44	0.9	40	2298				
	180.0	12	3.5	5	1331			PMRV040 - 71M/6B	73
	120.0	17	2.6	7.5	1524				
	90.0	22	2.0	10	1677				
	60.0	31	1.4	15	1920				
	45.0	40	1.1	20	2113				
	36.0	48	0.9	25	2276				
	30.0	53	0.9	30	2419				
	35.0	42	1.1	80	3153	PMRV050 - 63M/2B	74		
	28.0	48	0.8	100	3397				
	70.0	27	2.7	20	2503	PMRV050 - 71M/4A	74		
	56.0	32	2.2	25	2696				
	46.7	37	2.3	30	2865				
	35.0	46	1.7	40	3153				
	28.0	54	1.4	50	3397				
	23.3	60	1.1	60	3610				
	17.5	72	0.9	80	3973				
	45.0	40	1.9	20	2900	PMRV050 - 71M/6B	74		
	36.0	48	1.5	25	3124				
	30.0	54	1.7	30	3320				
	22.5	67	1.2	40	3654				
	18.0	78	1.0	50	3936				
	15.0	88	0.8	60	4183				
	18.7	88	1.0	75	3889	PPC071/PMRV050 - 71M/4A	83		
	15.6	98	1.1	90	4132				
	11.7	121	0.8	120	4548				
	28.0	56	2.4	50	4440	PMRV063 - 71M/4A	75		
	23.3	63	2.0	60	4719				
	17.5	78	1.6	80	5193				
	14.0	87	1.4	100	5595				
	18.0	81	1.8	50	5145	PMRV063 - 71M/6B	75		
	15.0	92	1.5	60	5467				
	11.3	110	1.2	80	6018				
	9.0	125	1.0	100	6270				
	18.7	91	1.8	75	5083	PPC071/PMRV063 - 71M/4A	83		
	15.6	100	2.0	90	5401				
	11.7	125	1.5	120	5945				
	9.3	143	1.2	150	6270				
	7.8	163	1.0	180	6270				
	5.8	192	0.7	240	6270				
	4.7	215	0.6	300	6270				
12.0	135	1.6	75	5889	PPC071/PMRV063 - 71M/6B	83			
10.0	148	1.8	90	6259					
7.5	181	1.3	120	6270					
6.0	211	1.0	150	6270					
7.0	159	1.4	400	6270	PMRV030/063 - 63M/2B	88			
5.6	185	1.2	500	6270					
17.5	82	2.3	80	6130	PMRV075 - 71M/4A	76			
14.0	94	1.9	100	6603	PMRV075 - 71M/4A	76			
11.3	117	1.7	80	7103	PMRV075 - 71M/6B	76			
9.0	133	1.4	100	7380					
9.3	151	1.7	150	7380	PPC071/PMRV075 - 71M/4A	84			
7.8	172	1.4	180	7380					
5.8	201	1.1	240	7380					
4.7	230	0.9	300	7380					

P <sub>1</sub> [kW]	n <sub>2</sub> [Min <sup>-1</sup> ]	M <sub>2</sub> [Nm]	f <sub>B</sub>	i <sub>ges</sub>	F <sub>R</sub> [N]	Tip / Type / Typ Tipo / Type / Tipo	 mm
0.25	12.0	139	2.4	75	6952	PPC071/PMRV075 - 71M/6B	84
	10.0	155	2.5	90	7380		
	7.5	191	1.9	120	7380		
	6.0	219	1.5	150	7380		
	5.0	248	1.2	180	7380		
	3.5	336	1.1	400	7380	PMRV040/75 - 71M/4A	88
	2.8	384	0.8	500	7380		
	5.0	263	1.9	180	8180	PPC071/PMRV090 - 71M/6B	84
	3.8	318	1.4	240	8180		
	3.0	358	1.1	300	8180		
	2.3	512	1.2	600	8180	PMRV040/090 - 71M/4A	88
	1.9	598	0.9	750	8180		
	1.6	667	0.8	900	8180		
	1.2	943	1.1	1200	10320	PMRV050/105 - 71M/4A	89
	0.93	1064	1.0	1500	10320		
	0.78	1195	0.9	1800	10320		
1.2	943	1.3	1200	10320	PMRV050/110 - 71M/4A	89	
0.93	1064	1.2	1500	10320			
0.78	1195	1.1	1800	10320			
0.6	1624	1.0	2400	13500	PMRV063/130 - 71M/4A	89	
0.47	1935	0.8	3000	13500			
0.35	2046	0.6	4000	13500			
0.28	2430	0.5	5000	13500			
0.8	1199	1.8	1800	18000	PMRV063/150 - 71M/4A	90	
0.6	1446	1.8	2400	18000			
0.5	1713	1.4	3000	18000			
0.4	2026	0.9	4000	18000			
0.3	2251	0.7	5000	18000			
0.37	560.0	5.6	2.1	5	474	PMRV030 - 63M/2C	72
	373.3	8.2	1.6	7.5	542		
	280.0	11	1.2	10	597		
	186.7	15	0.8	15	683		
	560.0	5.7	4.2	5	912	PMRV040 - 71M/2A	73
	373.3	8.4	3.3	7.5	1044		
	280.0	11	2.6	10	1149		
	186.7	16	1.9	15	1315		
	140.0	21	1.4	20	1447		
	112.0	25	1.1	25	1559		
	280.0	11	3.0	5	1149	PMRV040 - 71M/4B	73
	186.7	16	2.4	7.5	1315		
	140.0	21	1.9	10	1447		
	93.3	31	1.3	15	1657		
	70.0	39	1.0	20	1824		
	56.0	47	0.8	25	1964		
	46.7	53	0.8	30	2087		
	112.0	25	2.0	25	2140	PMRV050 - 71M/2A	74
	93.3	29	2.2	30	2274		
70.0	37	1.6	40	2503			
56.0	44	1.2	50	2696			
46.7	50	1.0	60	2865			
35.0	62	0.7	80	3153			

P <sub>1</sub> [kW]	n <sub>2</sub> [Min <sup>-1</sup> ]	M <sub>2</sub> [Nm]	f <sub>B</sub>	i <sub>ges</sub>	F <sub>R</sub> [N]	Tip / Type / Typ Tipo / Type / Tipo	 mm
0.37	140.0	22	3.3	10	1987	PMRV050 - 71M/4B	74
	93.3	31	2.4	15	2274		
	70.0	40	1.8	20	2503		
	56.0	48	1.5	25	2696		
	46.7	55	1.5	30	2865		
	35.0	68	1.1	40	3153		
	28.0	80	0.9	50	3397		
	23.3	89	0.8	60	3610		
	180.0	17	4.3	5	1827	PMRV050 - 80M/6A	74
	120.0	25	3.3	7.5	2091		
	90.0	33	2.5	10	2302		
	60.0	47	1.8	15	2635		
	45.0	60	1.3	20	2900		
	36.0	72	1.0	25	3124		
	30.0	80	1.1	30	3320		
	35.0	71	2.1	40	4122	PMRV063 - 71M/4B	75
	28.0	83	1.6	50	4440		
	23.3	94	1.4	60	4719		
	17.5	115	1.1	80	5193		
	14.0	129	0.9	100	5595		
	45.0	60	2.4	20	3791	PMRV063 - 80M/6A	75
	36.0	74	1.9	25	4084		
	30.0	82	2.1	30	4339		
	22.5	102	1.6	40	4776		
	18.0	120	1.2	50	5145		
	15.0	137	1.0	60	5467		
	18.7	134	1.2	75	5083	PPC071/PMRV063 - 71M/4B	83
	15.6	148	1.4	90	5401		
	11.7	185	1.0	120	5945		
	9.3	212	0.8	150	6270		
	9.3	181	1.3	300	6270	PMRV030/063 - 63M/2C	88
	7.0	236	1.0	400	6270		
	23.3	98	2.0	60	5569	PMRV075 - 71M/4B	76
	17.5	121	1.6	80	6130		
	14.0	139	1.3	100	6603		
	18.0	126	1.8	50	6073	PMRV075 - 80M/6A	76
	15.0	144	1.5	60	6453		
	11.3	173	1.2	80	7103		
	9.0	196	1.0	100	7380		
	18.7	138	1.8	75	6000	PPC071/PMRV075 - 71M/4B	84
	15.6	154	1.9	90	6375		
	11.7	191	1.5	120	7017		
9.3	223	1.1	150	7380			
7.8	254	0.9	180	7380			
12.0	206	1.6	75	6952	PPC080/PMRV075 - 80M/6A	84	
10.0	230	1.7	90	7380			
7.5	283	1.3	120	7380			
6.0	324	1.0	150	7380			
4.7	405	1.0	300	7380	PMRV040/075 - 71M/4B	88	
3.5	498	0.7	400	7380			
11.3	185	1.7	80	7859	PMRV090 - 80M/6A	77	
9.0	212	1.3	100	8180			

P <sub>1</sub> [kW]	n <sub>2</sub> [Min <sup>-1</sup> ]	M <sub>2</sub> [Nm]	f <sub>B</sub>	i <sub>ges</sub>	F <sub>R</sub> [N]	Tip / Type / Typ Tipo / Type / Tipo	 mm
0.37	7.8	268	1.5	180	8180	PPC071/PMRV090 - 71M/4B	84
	5.8	321	1.1	240	8180		
	4.7	371	0.9	300	8180		
	6.0	347	1.6	150	8180	PPC080/PMRV090 - 80M/6A	85
	5.0	389	1.3	180	8180		
	3.8	471	1.0	240	8180		
	4.7	402	1.5	300	8180	PMRV040/090 - 71M/4B	88
	3.5	523	1.2	400	8180		
	2.8	611	0.9	500	8180		
	2.3	757	0.8	600	8180		
	3.8	509	1.5	240	10320	PPC080/PMRV105 - 80M/6A	85
	3.0	577	1.2	300	10320		
	1.9	950	1.2	750	10320	PMRV050/105 - 71M/4B	89
	1.6	1079	1.0	900	10320		
	1.2	1396	0.7	1200	10320		
	3.8	509	1.6	240	10320	PPC080/PMRV110 - 80M/6A	85
	3.0	577	1.3	300	10320		
	1.9	950	1.3	750	10320	PMRV050/110 - 71M/4B	89
1.6	1079	1.2	900	10320			
1.2	1396	0.8	1200	10320			
0.9	1674	1.1	1500	13500	PMRV063/130 - 71M/4B	89	
0.78	1887	0.9	1800	13500			
0.8	1775	1.2	1800	18000	PMRV063/150 - 71M/4B	90	
0.6	2141	1.2	2400	18000			
0.5	2535	0.9	3000	18000			
0.55	560.0	8.4	2.8	5	912	PMRV040 - 71M/2B	73
	373.3	13	2.2	7.5	1044		
	280.0	17	1.8	10	1149		
	186.7	24	1.3	15	1315		
	140.0	31	0.9	20	1447		
	112.0	37	0.8	25	1559		
	280.0	17	2.0	5	1149	PMRV040 - 71M/4C	73
	186.7	24	1.6	7.5	1315		
	140.0	32	1.3	10	1447		
	93.3	46	0.9	15	1657		
	140.0	31	1.7	20	1987	PMRV050 - 71M/2B	74
	112.0	38	1.4	25	2140		
	93.3	43	1.5	30	2274		
	70.0	55	1.1	40	2503		
	56.0	65	0.8	50	2696		
	46.7	74	0.7	60	2865		
	280.0	17	3.7	5	1577	PMRV050 - 80M/4A	74
	186.7	25	2.9	7.5	1805		
	140.0	32	2.2	10	1987		
	93.3	46	1.6	15	2274		
	70.0	59	1.2	20	2503		
	56.0	71	1.0	25	2696		
	46.7	81	1.0	30	2865		
	120.0	38	2.2	7.5	2091	PMRV050 - 80M/6B	74
90.0	49	1.7	10	2302			
60.0	69	1.2	15	2635			
45.0	89	0.9	20	2900			

P <sub>1</sub> [kW]	n <sub>2</sub> [Min <sup>-1</sup> ]	M <sub>2</sub> [Nm]	f <sub>B</sub>	i <sub>ges</sub>	F <sub>R</sub> [N]	Tip / Type / Typ Tipo / Type / Tipo	 mm
0.55	70.0	56	1.9	40	3272	PMRV063 - 71M/2B	75
	56.0	67	1.5	50	3524		
	46.7	77	1.2	60	3745		
	35.0	95	0.9	80	4122		
	28.0	109	0.7	100	4440		
	70.0	61	2.2	20	3272	PMRV063 - 80M/4A	75
	56.0	73	1.8	25	3524		
	46.7	83	1.9	30	3745		
	35.0	105	1.4	40	4122		
	28.0	124	1.1	50	4440		
	23.3	140	0.9	60	4719		
	60.0	71	2.2	15	3444	PMRV063 - 80M/6B	75
	45.0	90	1.6	20	3791		
	36.0	109	1.3	25	4084		
	30.0	123	1.4	30	4339		
	22.5	152	1.1	40	4776		
	18.7	200	0.8	75	5083	PPC071/PMRV063 - 71M/4C	83
	15.6	219	0.9	90	5401		
	35.0	99	1.3	80	4865	PMRV075 - 71M/2B	76
	28.0	114	1.0	100	5241		
	35.0	108	2.0	40	4865	PMRV075 - 80M/4A	76
	28.0	129	1.6	50	5241		
	23.3	146	1.4	60	5569		
	17.5	180	1.1	80	6130		
	14.0	206	0.9	100	6603		
	30.0	128	2.0	30	5122	PMRV075 - 80M/6B	76
	22.5	159	1.5	40	5637		
	18.0	187	1.2	50	6073		
	15.0	214	1.0	60	6453		
	18.7	205	1.2	75	6000	PPC071/PMRV075 - 71M/4C	84
	15.6	230	1.3	90	6375		
	11.7	284	1.0	120	7017		
	18.7	205	1.2	75	6000	PPC080/PMRV075 - 80M/4A	84
	15.6	230	1.3	90	6375		
	11.7	284	1.0	120	7017		
	9.3	332	0.8	150	7380		
	12.0	306	1.1	75	6952	PPC080/PMRV075 - 80M/6B	84
	10.0	341	1.1	90	7380		
	17.5	189	1.5	80	6783	PMRV090 - 80M/4A	77
	14.0	221	1.2	100	7306		
	18.0	198	2.0	50	6719	PMRV090 - 80M/6B	77
	15.0	224	1.6	60	7140		
11.3	275	1.1	80	7859			
9.0	315	0.9	100	8180			
15.6	240	2.3	90	7054	PPC080/PMRV090 - 80M/4A	85	
11.7	297	1.6	120	7764			
9.3	355	1.3	150	8180			
7.8	398	1.0	180	8180			
10.0	357	2.0	90	8174	PPC080/PMRV090 - 80M/6B	85	
7.5	441	1.4	120	8180			
6.0	516	1.1	150	8180			
5.0	578	0.9	180	8180			
9.3	306	2.0	300	8180	PMRV040/090 - 71M/2B	88	
7.0	403	1.5	400	8180			
5.6	470	1.2	500	8180			

P <sub>1</sub> [kW]	n <sub>2</sub> [Min <sup>-1</sup> ]	M <sub>2</sub> [Nm]	f <sub>B</sub>	i <sub>ges</sub>	F <sub>R</sub> [N]	Tip / Type / Typ Tipo / Type / Tipo	 mm	
<b>0.55</b>	17.5 14.0	201 236	2.4 1.9	80 100	8571 9232	PMRV105 - 80M/4A	78	
	11.3 9.0	294 338	1.8 1.4	80 100	9931 10320	PMRV105 - 80M/6B	78	
	7.8 5.8 4.7	425 513 597	1.7 1.2 1.0	180 240 300	10320 10320 10320	PPC080/PMRV105 - 80M/4A	85	
	7.5 6.0 5.0 3.8	462 552 620 756	2.2 1.8 1.5 1.0	120 150 180 240	10320 10320 10320 10320	PPC080/PMRV105 - 80M/6B	85	
	4.7 3.5 2.8 2.3 1.9	639 826 984 1181 1411	1.7 1.2 1.0 0.9 0.8	300 400 500 600 750	10320 10320 10320 10320 10320	PMRV050/105 - 80M/4A	89	
	17.5 14.0	201 236	2.6 2.0	80 100	8571 9232	PMRV110 - 80M/4A	79	
	11.3 9.0	294 338	1.9 1.5	80 100	9931 10320	PMRV110 - 80M/6B	79	
	7.8 5.8 4.7	425 513 597	1.8 1.3 1.0	180 240 300	10320 10320 10320	PPC080/PMRV110 - 80M/4A	85	
	7.5 6.0 5.0 3.8	462 552 620 756	2.6 2.0 1.6 1.1	120 150 180 240	10320 10320 10320 10320	PPC080/PMRV110 - 80M/6B	85	
	4.7 3.5 2.8 2.3 1.9	639 826 984 1181 1411	2.0 1.4 1.1 1.0 0.9	300 400 500 600 750	10320 10320 10320 10320 10320	PMRV050/110 - 80M/4A	89	
	3.8 3.0	756 858	1.6 1.3	240 300	13500 13500	PPC080/PMRV130 - 80M/6B	86	
	2.8 1.9 1.2	996 1471 2132	1.6 1.2 0.8	500 750 1200	13500 13500 13500	PMRV063/130 - 80M/4A	89	
	0.8 0.6	2638 3182	0.8 0.8	1800 2400	18000 18000	PMRV063/150 - 80M/4A	90	
	<b>0.75</b>	560.0 373.3 280.0 186.7	12 17 23 32	2.1 1.6 1.3 1.0	5 7.5 10 15	912 1044 1149 1315	PMRV040 - 71M/2C	73
		560.0 373.3 280.0 186.7 140.0 112.0 93.3	12 17 23 33 42 51 58	3.9 3.0 2.4 1.7 1.3 1.0 1.1	5 7.5 10 15 20 25 30	1251 1433 1577 1805 1987 2140 2274	PMRV050 - 80M/2A	74

P <sub>1</sub> [kW]	n <sub>2</sub> [Min <sup>-1</sup> ]	M <sub>2</sub> [Nm]	f <sub>B</sub>	i <sub>ges</sub>	F <sub>R</sub> [N]	Tip / Type / Typ Tipo / Type / Tipo	 mm
<b>0.75</b>	280.0	23	2.7	5	1577	<b>PMRV050 - 80M/4B</b>	74
	186.7	34	2.1	7.5	1805		
	140.0	44	1.6	10	1987		
	93.3	63	1.2	15	2274		
	70.0	81	0.9	20	2503		
	140.0	43	2.3	20	2597	<b>PMRV063 - 80M/2A</b>	75
	112.0	52	1.8	25	2797		
	93.3	60	2.0	30	2973		
	70.0	77	1.4	40	3272		
	56.0	91	1.1	50	3524		
	46.7	104	0.9	60	3745		
	93.3	64	2.2	15	2973	<b>PMRV063 - 80M/4B</b>	75
	70.0	83	1.6	20	3272		
	56.0	100	1.3	25	3524		
	46.7	114	1.4	30	3745		
	35.0	143	1.0	40	4122		
	120.0	52	2.9	7.5	2734	<b>PMRV063 - 90S/6A</b>	75
	90.0	68	2.3	10	3009		
	60.0	97	1.6	15	3444		
	45.0	123	1.2	20	3791		
36.0	149	0.9	25	4084			
30.0	167	1.0	30	4339			
46.7	109	1.3	60	4421	<b>PMRV075 - 80M/2A</b>	76	
28.0	156	0.8	100	5241			
56.0	102	2.0	25	4160	<b>PMRV075 - 80M/4B</b>	76	
46.7	117	2.0	30	4421			
35.0	147	1.5	40	4865			
28.0	177	1.2	50	5241			
23.3	200	1.0	60	5569			
60.0	98	2.4	15	4065	<b>PMRV075 - 90S/6A</b>	76	
45.0	126	1.9	20	4474			
36.0	153	1.4	25	4820			
30.0	174	1.5	30	5122			
22.5	216	1.1	40	5637			
18.7	280	0.9	75	6000	<b>PPC080/PMRV075 - 80M/4B</b>	84	
15.6	313	1.0	90	6375			
35.0	141	1.6	80	5383	<b>PMRV090 - 80M/2A</b>	77	
28.0	166	1.2	100	5799			
28.0	184	1.8	50	5799	<b>PMRV090 - 80M/4B</b>	77	
23.3	212	1.5	60	6163			
17.5	258	1.1	80	6783			
14.0	302	0.9	100	7306			
30.0	179	2.6	30	5667	<b>PMRV090 - 90S/6A</b>	77	
22.5	226	1.8	40	6238			
18.0	271	1.4	50	6719			
15.0	306	1.1	60	7140			
15.6	327	1.7	90	7054	<b>PPC080/PMRV090 - 80M/4B</b>	85	
11.7	405	1.2	120	7764			
9.3	483	0.9	150	8180			
7.8	543	0.7	180	8180			
7.0	549	1.1	400	8180	<b>PMRV040/090 - 71M/2C</b>	88	
5.6	642	0.9	500	8180			
17.5	274	1.8	80	8571	<b>PMRV105 - 80M/4B</b>	78	
14.0	322	1.4	100	9232			

P <sub>1</sub> [kW]	n <sub>2</sub> [Min <sup>-1</sup> ]	M <sub>2</sub> [Nm]	f <sub>B</sub>	i <sub>ges</sub>	F <sub>R</sub> [N]	Tip / Type / Typ Tipo / Type / Tipo	 mm
<b>0.75</b>	15.0	325	1.9	60	9023	<b>PMRV105 - 90S/6A</b>	78
	11.3	401	1.3	80	9931		
	9.0	462	1.1	100	10320		
	11.7	430	1.9	120	9811	<b>PPC080/PMRV105 - 80M/4B</b>	85
	9.3	506	1.6	150	10320		
	7.8	580	1.2	180	10320		
	5.8	700	0.9	240	10320		
	12.4	393	2.8	73	9614	<b>PPC090/PMRV105 - 90S/6A</b>	85
	9.3	508	2.0	96.8	10320		
	7.4	607	1.6	121	10320		
	6.2	682	1.3	145.2	10320		
	4.6	832	0.9	193.6	10320		
	9.3	446	2.5	300	10320	<b>PMRV050/105 - 80M/2A</b>	89
	7.0	563	1.8	400	10320		
	5.6	687	1.5	500	10320		
	4.7	871	1.3	300	10320	<b>PMRV050/105 - 80M/4B</b>	89
	3.5	1126	0.9	400	10320		
	17.5	274	1.9	80	8571	<b>PMRV110 - 80M/4B</b>	79
	14.0	322	1.5	100	9232		
	15.0	325	2.1	60	9023	<b>PMRV110 - 90S/6A</b>	79
	11.3	401	1.4	80	9931		
	9.0	462	1.1	100	10320		
	11.7	430	2.2	120	9811	<b>PPC080/PMRV110 - 80M/4B</b>	85
	9.3	506	1.7	150	10320		
	7.8	580	1.3	180	10320		
	5.8	700	0.9	240	10320		
	12.4	393	3.2	73	9614	<b>PPC090/PMRV110 - 90S/6A</b>	85
	9.3	508	2.3	96.8	10320		
	7.4	607	1.8	121	10320		
	6.2	682	1.5	145.2	10320		
	4.6	832	1.0	193.6	10320		
	9.3	446	2.8	300	10320	<b>PMRV050/110 - 80M/2A</b>	89
	7.0	563	2.1	400	10320		
	5.6	687	1.6	500	10320		
	4.7	871	1.5	300	10320	<b>PMRV050/110 - 80M/4B</b>	89
	3.5	1126	1.1	400	10320		
	11.3	407	2.1	80	12989	<b>PMRV130 - 90S/6A</b>	80
	9.0	470	1.7	100	13500		
	5.8	712	1.4	240	13500	<b>PPC080/PMRV130 - 80M/4B</b>	86
	4.7	813	1.1	300	13500		
	12.4	399	4.4	73	12575	<b>PPC090/PMRV130 - 90S/6A</b>	86
	9.3	508	3.2	96.8	13500		
	7.4	607	2.6	121	13500		
	6.2	682	2.1	145.2	13500		
	4.6	832	1.5	193.6	13500		
	3.7	944	1.2	242	13500		
	2.8	1358	1.1	500	13500	<b>PMRV063/130 - 80M/4B</b>	89
	2.3	1631	1.0	600	13500		
	1.9	2005	0.9	750	13500		
	1.6	2283	0.8	900	13500		





P <sub>1</sub> [kW]	n <sub>2</sub> [Min <sup>-1</sup> ]	M <sub>2</sub> [Nm]	f <sub>B</sub>	i <sub>ges</sub>	F <sub>R</sub> [N]	Tip / Type / Typ Tipo / Type / Tipo	 mm
<b>0.75</b>	2.8	1291	1.8	500	18000	<b>PMRV063/150 - 80M/4B</b>	90
	2.3	1529	1.7	600	18000		
	1.9	1783	1.3	750	18000		
	1.6	2215	0.9	900	18000		
	1.2	2680	1.0	1200	18000		
<b>0.92</b>	280.0	28	2.2	5	1577	<b>PMRV050 - 80C4</b>	74
	186.7	41	1.7	7.5	1805		
	140.0	54	1.3	10	1987		
	93.3	77	1.0	15	2274		
	140.0	55	2.4	10	2597	<b>PMRV063 - 80C4</b>	75
	93.3	78	1.8	15	2973		
	70.0	102	1.3	20	3272		
	56.0	122	1.1	25	3524		
	46.7	139	1.1	30	3745		
	35.0	176	0.8	40	4122		
	70.0	103	2.0	20	3862	<b>PMRV075 - 80C4</b>	76
	56.0	126	1.6	25	4160		
	46.7	143	1.6	30	4421		
	35.0	181	1.2	40	4865		
	28.0	217	1.0	50	5241		
	23.3	245	0.8	60	5569		
	18.7	344	0.7	75	6000	<b>PPC080/PMRV075 - 80C4</b>	84
	15.6	384	0.8	90	6375		
	28.0	226	1.5	50	5799	<b>PMRV090 - 80C4</b>	77
	23.3	260	1.2	60	6163		
	17.5	316	0.9	80	6783		
	15.6	401	1.4	90	7054	<b>PPC080/PMRV090 - 80C4</b>	85
	11.7	497	1.0	120	7764		
	9.3	593	0.8	150	8180		
	17.5	336	1.5	80	8571	<b>PMRV105 - 80C4</b>	78
	14.0	395	1.2	100	9232		
	18.7	367	2.2	75	8388	<b>PPC080/PMRV105 - 80C4</b>	85
	11.7	527	1.5	120	9811		
	9.3	621	1.3	150	10320		
	7.8	712	1.0	180	10320		
	4.7	1069	1.0	300	10320	<b>PMRV050/105 - 80C4</b>	89
	3.5	1382	0.7	400	10320		
17.5	336	1.5	80	8571	<b>PMRV110 - 80C4</b>	79	
14.0	395	1.2	100	9232			
18.7	367	2.5	75	8388	<b>PPC080/PMRV110 - 80C4</b>	85	
11.7	527	1.8	120	9811			
9.3	621	1.4	150	10320			
7.8	712	1.1	180	10320			
4.7	1069	1.2	300	10320	<b>PMRV050/110 - 80C4</b>	89	
3.5	1382	0.9	400	10320			
3.5	1398	1.2	400	13500	<b>PMRV063/130 - 80C4</b>	89	
2.8	1665	0.9	500	13500			
7.8	712	1.5	180	13500	<b>PPC080/PMRV130 - 80C4</b>	86	
5.8	874	1.1	240	13500			
4.7	998	0.9	300	13500			

P <sub>1</sub> [kW]	n <sub>2</sub> [Min <sup>-1</sup> ]	M <sub>2</sub> [Nm]	f <sub>B</sub>	i <sub>ges</sub>	F <sub>R</sub> [N]	Tip / Type / Typ Tipo / Type / Tipo	 mm
<b>0.92</b>	2.8	1583	1.5	500	18000	<b>PMRV063/150 - 80C4</b>	90
	2.3	1875	1.4	600	18000		
	1.9	2188	1.1	750	18000		
	1.6	2717	0.8	900	18000		
	1.2	3288	0.8	1200	18000		
<b>1.10</b>	560.0	17	2.6	5	1251	<b>PMRV050 - 80M/2B</b>	74
	373.3	25	2.1	7.5	1433		
	280.0	33	1.6	10	1577		
	186.7	48	1.2	15	1805		
	140.0	62	0.9	20	1987		
	186.7	48	2.1	15	2359	<b>PMRV063 - 80M/2B</b>	75
	140.0	63	1.6	20	2597		
	112.0	77	1.2	25	2797		
	93.3	88	1.4	30	2973		
	70.0	113	1.0	40	3272		
	120.0	76	2.0	7.5	2734	<b>PMRV063 - 90L/6B</b>	75
	90.0	99	1.5	10	3009		
	60.0	142	1.1	15	3444		
	45.0	180	0.8	20	3791		
	186.7	50	2.6	7.5	2359	<b>PMRV063 - 90S/4A</b>	75
	140.0	65	2.0	10	2597		
	93.3	93	1.5	15	2973		
	70.0	122	1.1	20	3272		
	56.0	146	0.9	25	3524		
	46.7	167	1.0	30	3745		
	112.0	78	1.9	25	3302	<b>PMRV075 - 80M/2B</b>	76
	93.3	90	1.9	30	3509		
	70.0	116	1.4	40	3862		
	56.0	139	1.1	50	4160		
	46.7	160	0.9	60	4421		
	90.0	100	2.3	10	3551	<b>PMRV075 - 90L/6B</b>	76
	60.0	144	1.6	15	4065		
	45.0	184	1.3	20	4474		
	36.0	225	1.0	25	4820		
	30.0	256	1.0	30	5122		
	93.3	96	2.1	15	3509	<b>PMRV075 - 90S/4A</b>	76
	70.0	123	1.7	20	3862		
56.0	150	1.3	25	4160			
46.7	171	1.3	30	4421			
35.0	216	1.0	40	4865			
35.0	207	1.1	80	5383	<b>PMRV090 - 80M/2B</b>	77	
28.0	244	0.8	100	5799			
36.0	231	1.6	25	5333	<b>PMRV090 - 90L/6B</b>	77	
30.0	263	1.8	30	5667			
22.5	331	1.2	40	6238			
18.0	397	1.0	50	6719			
15.0	448	0.8	60	7140			
35.0	225	1.6	40	5383	<b>PMRV090 - 90S/4A</b>	77	
28.0	270	1.3	50	5799			
23.3	311	1.0	60	6163			
22.5	345	2.0	40	7882	<b>PMRV105 - 90L/6B</b>	78	
18.0	414	1.6	50	8491			
15.0	476	1.3	60	9023			
11.3	588	0.9	80	9931			

P <sub>1</sub> [kW]	n <sub>2</sub> [Min <sup>-1</sup> ]	M <sub>2</sub> [Nm]	f <sub>B</sub>	i <sub>ges</sub>	F <sub>R</sub> [N]	Tip / Type / Typ Tipo / Type / Tipo	 mm
1.10	28.0	281	2.1	50	7328	PMRV105 - 90S/4A	78
	23.3	324	1.7	60	7787		
	17.5	402	1.2	80	8571		
	14.0	473	1.0	100	9232		
	12.4	576	1.9	73	9614	PPC090/PMRV105 - 90L/6B	85
	9.3	746	1.4	96.8	10320		
	7.4	890	1.1	121	10320		
	6.2	1000	0.9	145.2	10320		
	19.3	392	2.2	73	8298	PPC090/PMRV105 - 90S/4A	85
	14.5	508	1.6	96.8	9133		
	11.6	599	1.3	121	9838		
	9.6	686	1.0	145.2	10320		
	7.2	828	0.8	193.6	10320		
	9.3	654	1.7	300	10320	PMRV050/105 - 80M/2B	89
	7.0	845	1.2	400	10320		
	5.6	1007	1.0	500	10320		
	22.5	345	2.3	40	7882	PMRV110 - 90L/6B	79
	18.0	414	1.8	50	8491		
	15.0	476	1.4	60	9023		
	11.3	588	1.0	80	9931		
	28.0	281	2.3	50	7328	PMRV110 - 90S/4A	79
	23.3	324	1.9	60	7787		
	17.5	402	1.3	80	8571		
	14.0	473	1.0	100	9232		
	12.4	576	2.2	73	9614	PPC090/PMRV110 - 90L/6B	85
	9.3	746	1.6	96.8	10320		
	7.4	890	1.2	121	10320		
	6.2	1000	1.0	145.2	10320		
	19.3	392	2.5	73	8298		
	14.5	508	1.8	96.8	9133	PPC090/PMRV110 - 90S/4A	85
	11.6	599	1.5	121	9838		
	9.6	686	1.1	145.2	10320		
7.2	828	0.8	193.6	10320			
9.3	654	1.9	300	10320			
7.0	845	1.4	400	10320	PMRV050/110 - 80M/2B	89	
5.6	1007	1.1	500	10320			
11.3	598	1.4	80	12989			
9.0	689	1.1	100	13500	PMRV130 - 90L/6B	80	
17.5	408	2.1	80	11210	PMRV130 - 90S/4A	80	
14.0	480	1.5	100	12076			
12.4	585	3.0	73	12575	PPC090/PMRV130 - 90L/6B	86	
9.3	746	2.2	96.8	13500			
7.4	890	1.7	121	13500			
6.2	1000	1.4	145.2	13500			
4.6	1220	1.0	193.6	13500			
19.3	398	3.5	73	10853			PPC090/PMRV130 - 90S/4A
14.5	508	2.6	96.8	11945			
11.6	608	2.0	121	12868			
9.6	686	1.6	145.2	13500			
7.2	843	1.2	193.6	13500			
5.8	962	0.9	242	13500			

P <sub>1</sub> [kW]	n <sub>2</sub> [Min <sup>-1</sup> ]	M <sub>2</sub> [Nm]	f <sub>B</sub>	i <sub>ges</sub>	F <sub>R</sub> [N]	Tip / Type / Typ Tipo / Type / Tipo	 mm	
1.10	4.7	1312	1.3	300	13500	PMRV063/130 - 90S/4A	89	
	3.5	1671	1.0	400	13500			
	2.8	1991	0.8	500	13500			
	9.3	753	3.1	150	18000	PMRV063/150 - 90S/4A	90	
	7.0	966	2.4	200	18000			
	5.6	1175	1.7	250	18000			
	4.7	1364	1.7	300	18000			
	3.5	1619	1.6	400	18000			
	2.8	1893	1.2	500	18000			
	2.3	2242	1.2	600	18000			
	1.9	2616	0.9	750	18000			
	1.50	560.0	23	1.9	5	1251	PMRV050 - 80M/2C	74
		373.3	35	1.5	7.5	1433		
		280.0	45	1.2	10	1577		
186.7		65	0.9	15	1805			
186.7		68	1.9	7.5	2359	PMRV063 - 90L/4A	75	
140.0		89	1.5	10	2597			
93.3		127	1.1	15	2973			
70.0		166	0.8	20	3272			
373.3		35	2.7	7.5	1873	PMRV063 - 90S/2A	75	
280.0		46	2.1	10	2061			
186.7		66	1.6	15	2359			
140.0		86	1.2	20	2597			
112.0		105	0.9	25	2797			
93.3		120	1.0	30	2973			
120.0		105	2.0	7.5	3227	PMRV075 - 100L/6A	76	
90.0		137	1.7	10	3551			
60.0		196	1.2	15	4065			
56.0		189	0.8	50	4160	PMRV075 - 90S/2A	76	
46.7		218	0.7	60	4421			
140.0		90	2.2	10	3065	PMRV075 - 90L/4A	76	
93.3		130	1.5	15	3509			
70.0		168	1.3	20	3862			
56.0		205	1.0	25	4160			
46.7		233	1.0	30	4421			
280.0		46	3.1	10	2433	PMRV075 - 90S/2A	76	
186.7		67	2.2	15	2785			
140.0		87	1.8	20	3065			
112.0		106	1.4	25	3302			
93.3		123	1.4	30	3509			
70.0		158	1.0	40	3862			
90.0	138	2.7	10	3929	PMRV090 - 100L/6A	77		
60.0	201	2.1	15	4498				
45.0	258	1.5	20	4951				
36.0	314	1.2	25	5333				
30.0	358	1.3	30	5667				
70.0	172	2.1	20	4273	PMRV090 - 90L/4A	77		
56.0	210	1.6	25	4603				
46.7	239	1.7	30	4891				
35.0	307	1.2	40	5383				
28.0	368	0.9	50	5799				
23.3	424	0.8	60	6163				
56.0	194	1.4	50	4603	PMRV090 - 90S/2A	77		
46.7	227	1.1	60	4891				

P <sub>1</sub> [kW]	n <sub>2</sub> [Min <sup>-1</sup> ]	M <sub>2</sub> [Nm]	f <sub>B</sub>	i <sub>ges</sub>	F <sub>R</sub> [N]	Tip / Type / Typ Tipo / Type / Tipo	 mm
<b>1.50</b>	45.0	264	2.4	20	6256	<b>PMRV105 - 100L/6A</b>	78
	36.0	322	2.0	25	6739		
	30.0	363	2.0	30	7161		
	22.5	471	1.5	40	7882		
	18.0	565	1.2	50	8491		
	15.0	649	1.0	60	9023		
	35.0	319	1.9	40	6803	<b>PMRV105 - 90L/4A</b>	78
	28.0	384	1.6	50	7328		
	23.3	442	1.3	60	7787		
	17.5	548	0.9	80	8571		
	46.7	236	1.8	60	6181	<b>PMRV105 - 90S/2A</b>	78
	35.0	299	1.3	80	6803		
	28.0	353	1.0	100	7328		
	19.3	535	1.6	73	8298	<b>PPC090/PMRV105 - 90L/4A</b>	85
	14.5	693	1.2	96.8	9133		
	11.6	817	1.0	121	9838		
	9.6	936	0.8	145.2	10320		
	9.3	891	1.2	300	10320	<b>PMRV050/105- 80M/2C</b>	89
	7.0	1153	0.9	400	10320		
	5.6	1373	0.7	500	10320		
	45.0	264	2.7	20	6256	<b>PMRV110 - 100L/6A</b>	79
	36.0	322	2.4	25	6739		
	30.0	363	2.3	30	7161		
	22.5	471	1.7	40	7882		
	18.0	565	1.3	50	8491		
	15.0	649	1.1	60	9023		
	35.0	319	2.2	40	6803	<b>PMRV110 - 90L/4A</b>	79
	28.0	384	1.7	50	7328		
	23.3	442	1.4	60	7787		
	17.5	548	0.9	80	8571		
	46.7	236	2.0	60	6181	<b>PMRV110 - 90S/2A</b>	79
	35.0	299	1.3	80	6803		
	28.0	353	1.0	100	7328		
	19.3	535	1.9	73	8298	<b>PPC090/PMRV110 - 90L/4A</b>	85
	14.5	693	1.3	96.8	9133		
	11.6	817	1.1	121	9838		
9.6	936	0.8	145.2	10320			
9.3	891	1.4	300	10320	<b>PMRV050/110 - 80M/2C</b>	89	
7.0	1153	1.0	400	10320			
5.6	1373	0.8	500	10320			
22.5	478	2.3	40	10309	<b>PMRV130 - 100L/6A</b>	80	
18.0	573	1.8	50	11105			
15.0	659	1.4	60	11801			
11.3	815	1.1	80	12989			
17.5	557	1.5	80	11210	<b>PMRV130 - 90L/4A</b>	80	
14.0	655	1.1	100	12076			
19.3	542	2.6	73	10853	<b>PPC090/PMRV130 - 90L/4A</b>	86	
14.5	693	1.9	96.8	11945			
11.6	830	1.5	121	12868			
9.6	936	1.1	145.2	13500			
7.2	1149	0.8	194	13500			
9.3	915	1.9	300	13500			
7.0	1166	1.4	400	13500	<b>PMRV063/130 - 90S/2A</b>	89	
5.6	1389	1.1	500	13500			

P <sub>1</sub> [kW]	n <sub>2</sub> [Min <sup>-1</sup> ]	M <sub>2</sub> [Nm]	f <sub>B</sub>	i <sub>ges</sub>	F <sub>R</sub> [N]	Tip / Type / Typ Tipo / Type / Tipo	 mm
1.50	4.7	1789	1.0	300	13500	PMRV063/130 - 90L/4A	89
	3.5	2279	0.7	400	13500		
	9.3	1026	2.3	150	18000	PMRV063/150 - 90L/4A	90
	7.0	1317	1.8	200	18000		
	5.6	1602	1.3	250	18000		
	4.7	1860	1.3	300	18000		
	3.5	2208	1.2	400	18000		
	2.8	2582	0.9	500	18000		
2.3	3057	0.9	600	18000			
1.84	186.7	83	1.5	7.5	2359	PMRV063 - 90LL4	75
	140.0	109	1.2	10	2597		
	93.3	156	0.9	15	2973		
	186.7	84	2.2	7.5	2785	PMRV075 - 90LL4	76
	140.0	110	1.8	10	3065		
	93.3	160	1.2	15	3509		
	70.0	206	1.0	20	3862		
	56.0	251	0.8	25	4160		
	46.7	286	0.8	30	4421		
	70.0	211	1.7	20	4273	PMRV090 - 90LL4	77
	56.0	257	1.3	25	4603		
	46.7	294	1.4	30	4891		
	35.0	377	1.0	40	5383		
	28.0	452	0.8	50	5799		
	56.0	264	2.2	25	5816	PMRV105 - 90LL4	78
	35.0	392	1.6	40	6803		
	28.0	471	1.3	50	7328		
	23.3	542	1.0	60	7787		
	19.3	656	1.3	73	8298	PPC090/PMRV105 - 90LL4	85
	14.5	850	1.0	96.8	9133		
	11.6	1002	0.8	121	9838		
	56.0	264	2.6	25	5816	PMRV110 - 90LL4	79
	35.0	392	1.8	40	6803		
	28.0	471	1.4	50	7328		
	23.3	542	1.1	60	7787		
	19.3	656	1.5	73	8298	PPC090/PMRV110 - 90LL4	85
	14.5	850	1.1	96.8	9133		
	11.6	1002	0.9	121	9838		
17.5	683	1.2	80	11210	PMRV130 - 90LL4	80	
14.0	803	0.9	100	12076			
19.3	665	2.1	73	10853	PPC090/PMRV130 - 90LL4	86	
14.5	850	1.5	96.8	11945			
11.6	1018	1.2	121	12868			
9.6	1148	0.9	145.2	13500			
9.3	1259	1.9	150	18000	PMRV063/150 - 90LL4	90	
7.0	1616	1.4	200	18000			
5.6	1966	1.0	250	18000			
4.7	2281	1.0	300	18000			
3.5	2708	1.0	400	18000			
2.8	3167	0.7	500	18000			

P <sub>1</sub> [kW]	n <sub>2</sub> [Min <sup>-1</sup> ]	M <sub>2</sub> [Nm]	f <sub>B</sub>	i <sub>ges</sub>	F <sub>R</sub> [N]	Tip / Type / Typ Tipo / Type / Tipo	 mm
<b>2.20</b>	373.3	51	1.8	7.5	1873	<b>PMRV063 - 90L/2A</b>	75
	280.0	67	1.5	10	2061		
	186.7	97	1.1	15	2359		
	186.7	100	1.8	7.5	2785	<b>PMRV075 - 100L/4A</b>	76
	140.0	132	1.5	10	3065		
	93.3	191	1.0	15	3509		
	373.3	51	2.5	7.5	2210	<b>PMRV075 - 90L/2A</b>	76
	280.0	68	2.1	10	2433		
	186.7	98	1.5	15	2785		
	140.0	128	1.3	20	3065		
	112.0	156	1.0	25	3302		
	93.3	180	0.9	30	3509		
	186.7	101	2.9	7.5	3081	<b>PMRV090 - 100L/4A</b>	77
	140.0	134	2.3	10	3391		
	93.3	194	1.9	15	3882		
	70.0	252	1.4	20	4273		
	56.0	308	1.1	25	4603		
	46.7	351	1.2	30	4891		
	120.0	156	2.2	7.5	3570	<b>PMRV090 - 112M/6A</b>	77
	90.0	203	1.8	10	3929		
60.0	294	1.4	15	4498			
45.0	378	1.0	20	4951			
140.0	131	2.0	20	3391	<b>PMRV090 - 90L/2A</b>	77	
112.0	159	1.6	25	3653			
93.3	185	1.7	30	3882			
70.0	237	1.2	40	4273			
56.0	285	0.9	50	4603			
70.0	255	2.2	20	5399	<b>PMRV105 - 100L/4A</b>	78	
56.0	315	1.9	25	5816			
46.7	356	1.8	30	6181			
35.0	468	1.3	40	6803			
28.0	563	1.1	50	7328			
23.3	648	0.9	60	7787			
90.0	205	3.0	10	4965	<b>PMRV105 - 112M/6A</b>	78	
60.0	298	2.2	15	5684			
45.0	388	1.6	20	6256			
36.0	473	1.4	25	6739			
30.0	532	1.4	30	7161			
112.0	163	2.7	25	4616	<b>PMRV105 - 90L/2A</b>	78	
93.3	187	2.6	30	4905			
70.0	246	1.9	40	5399			
56.0	296	1.5	50	5816			
46.7	347	1.2	60	6181			
38.6	398	1.8	73	6586	<b>PPC090/PMRV105 - 90L/2A</b>	85	
28.9	516	1.3	96.8	7249			
23.1	617	1.1	121	7809			
70.0	255	2.5	20	5399	<b>PMRV110 - 100L/4A</b>	79	
56.0	315	2.2	25	5816			
46.7	356	2.0	30	6181			
35.0	468	1.5	40	6803			
28.0	563	1.2	50	7328			
23.3	648	1.0	60	7787			

P <sub>1</sub> [kW]	n <sub>2</sub> [Min <sup>-1</sup> ]	M <sub>2</sub> [Nm]	f <sub>B</sub>	i <sub>ges</sub>	F <sub>R</sub> [N]	Tip / Type / Typ Tipo / Type / Tipo	 mm
<b>2.20</b>	90.0	205	3.5	10	4965	<b>PMRV110 - 112M/6A</b>	79
	60.0	298	2.6	15	5684		
	45.0	388	1.9	20	6256		
	36.0	473	1.6	25	6739		
	30.0	532	1.6	30	7161		
	112.0	163	3.1	25	4616	<b>PMRV110 - 90L/2A</b>	79
	93.3	187	3.0	30	4905		
	70.0	246	2.1	40	5399		
	56.0	296	1.7	50	5816		
	46.7	347	1.4	60	6181		
	38.6	398	2.1	73	6586	<b>PPC090/PMRV110 - 90L/2A</b>	85
	28.9	516	1.5	96.8	7249		
	23.1	617	1.2	121	7809		
	35.0	468	2.2	40	8897	<b>PMRV130 - 100L/4A</b>	80
	28.0	563	1.7	50	9584		
	23.3	648	1.4	60	10185		
	17.5	816	1.0	80	11210		
	36.0	479	2.2	25	8814	<b>PMRV130 - 112M/6A</b>	80
	30.0	546	2.1	30	9366		
	22.5	700	1.6	40	10309		
	18.0	840	1.2	50	11105		
	15.0	966	1.0	60	11801		
	35.0	438	1.3	80	8897	<b>PMRV130 - 90L/2A</b>	80
	28.0	525	1.0	100	9584		
38.6	409	2.9	73	8614	<b>PPC090/PMRV130 - 90L/2A</b>	86	
28.9	545	2.0	96.8	9481			
23.1	654	1.6	121	10213			
19.3	752	1.3	145.2	10853			
28.0	570	2.5	50	13103	<b>PMRV150 - 100L/4A</b>	81	
23.3	657	1.9	60	13924			
17.5	816	1.4	80	15325			
14.0	960	1.0	100	16508			
<b>3.00</b>	373.3	70	1.9	7.5	2210	<b>PMRV075 - 100L/2A</b>	76
	280.0	92	1.6	10	2433		
	186.7	137	1.4	7.5	2785	<b>PMRV075 - 100L/4B</b>	76
	140.0	180	1.1	10	3065		
	93.3	261	0.8	15	3509		
	373.3	71	3.0	7.5	2446	<b>PMRV090 - 100L/2A</b>	77
	280.0	92	2.6	10	2692		
	186.7	138	2.1	7.5	3081	<b>PMRV090 - 100L/4B</b>	77
	140.0	182	1.7	10	3391		
	93.3	264	1.4	15	3882		
	70.0	344	1.0	20	4273		
	56.0	420	0.8	25	4603		
	46.7	479	0.9	30	4891		
	93.3	264	2.2	15	4905	<b>PMRV105 - 100L/4B</b>	78
70.0	348	1.6	20	5399			
56.0	430	1.4	25	5816			
46.7	485	1.3	30	6181			
35.0	638	1.0	40	6803			
28.0	767	0.8	50	7328			



P <sub>1</sub> [kW]	n <sub>2</sub> [Min <sup>-1</sup> ]	M <sub>2</sub> [Nm]	f <sub>B</sub>	i <sub>ges</sub>	F <sub>R</sub> [N]	Tip / Type / Typ Tipo / Type / Tipo	 mm
3.00	120.0	212	2.7	7.5	4511	PMRV105 - 132S/6B	78
	90.0	280	2.2	10	4965		
	60.0	406	1.6	15	5684		
	45.0	528	1.2	20	6256		
	93.3	264	2.5	15	4905	PMRV110 - 100L/4B	79
	70.0	348	1.9	20	5399		
	56.0	430	1.6	25	5816		
	46.7	485	1.5	30	6181		
	35.0	638	1.1	40	6803		
	28.0	767	0.9	50	7328		
	120.0	212	3.1	7.5	4511	PMRV110 - 132S/6B	79
	90.0	280	2.5	10	4965		
	60.0	406	1.9	15	5684		
	45.0	528	1.4	20	6256		
	56.0	430	2.2	25	7607	PMRV130 - 100L/4B	80
	46.7	491	2.1	30	8084		
35.0	638	1.6	40	8897			
28.0	767	1.3	50	9584			
23.3	884	1.0	60	10185			
17.5	1113	0.8	80	11210			
90.0	280	3.4	10	6494	PMRV130 - 132S/6B	80	
60.0	406	2.6	15	7434			
45.0	535	1.9	20	8182			
36.0	653	1.6	25	8814			
30.0	745	1.6	30	9366			
22.5	955	1.2	40	10309			
28.0	778	1.8	50	13103	PMRV150 - 100L/4B	81	
23.3	896	1.4	60	13924			
17.5	1113	1.0	80	15325			
14.0	1310	0.8	100	16508			
4.00	373.3	93	1.4	7.5	2210	PMRV075 - 112M/2A	76
	280.0	123	1.2	10	2433		
	186.7	182	1.0	7.5	2785	PMRV075 - 112M/4B	76
	140.0	240	0.8	10	3065		
	373.3	94	2.2	7.5	2446	PMRV090 - 112M/2A	77
	280.0	123	1.9	10	2692		
	186.7	184	1.6	7.5	3081	PMRV090 - 112M/4B	77
	140.0	243	1.3	10	3391		
	93.3	352	1.0	15	3882		
	70.0	458	0.8	20	4273		
	140.0	243	2.1	10	4285	PMRV105 - 112M/4B	78
	93.3	352	1.6	15	4905		
	70.0	464	1.2	20	5399		
	56.0	573	1.0	25	5816		
	46.7	647	1.0	30	6181		
120.0	283	2.0	7.5	4511	PMRV105 - 132M/6A	78	
90.0	374	1.7	10	4965			
60.0	541	1.2	15	5684			
140.0	243	2.5	10	4285	PMRV110 - 112M/4B	79	
93.3	352	1.9	15	4905			
70.0	464	1.4	20	5399			
56.0	573	1.2	25	5816			
46.7	647	1.1	30	6181			

P <sub>1</sub> [kW]	n <sub>2</sub> [Min <sup>-1</sup> ]	M <sub>2</sub> [Nm]	f <sub>B</sub>	i <sub>ges</sub>	F <sub>R</sub> [N]	Tip / Type / Typ Tipo / Type / Tipo	 mm
<b>4.00</b>	120.0	283	2.3	7.5	4511	<b>PMRV110 - 132M/6A</b>	79
	90.0	374	1.9	10	4965		
	60.0	541	1.4	15	5684		
	<b>PMRV130 - 112M/4B</b>	56.0	573	1.6	25	7607	80
		46.7	655	1.6	30	8084	
		35.0	851	1.2	40	8897	
		28.0	1023	1.0	50	9584	
		23.3	1179	0.8	60	10185	
		120.0	287	3.1	7.5	5901	
	90.0	374	2.6	10	6494		
	60.0	541	2.0	15	7434		
	45.0	713	1.5	20	8182		
	36.0	870	1.2	25	8814		
	<b>PMRV150 - 112M/4B</b>	28.0	1037	1.4	50	13103	81
		23.3	1195	1.1	60	13924	
17.5		1484	0.8	80	15325		
<b>4.80</b>	186.7	221	1.3	7.5	3081	<b>PMRV090 - 112MS4</b>	77
	140.0	291	1.1	10	3391		
	93.3	422	0.9	15	3882		
	<b>PMRV105 - 112MS4</b>	186.7	221	2.2	7.5	3893	78
		140.0	291	1.8	10	4285	
		93.3	422	1.3	15	4905	
		70.0	557	1.0	20	5399	
	<b>PMRV110 - 112MS4</b>	56.0	688	0.9	25	5816	79
		186.7	221	2.5	7.5	3893	
		140.0	291	2.1	10	4285	
		93.3	422	1.6	15	4905	
	<b>PMRV130 - 112MS4</b>	70.0	557	1.2	20	5399	80
		56.0	688	1.0	25	5816	
		56.0	688	1.4	25	7607	
		46.7	786	1.3	30	8084	
35.0		1022	1.0	40	8897		
28.0		1228	0.8	50	9584		
23.3		1434	0.9	60	13924		
<b>5.50</b>	186.7	253	1.9	7.5	3893	<b>PMRV105 - 132S/4C</b>	78
	140.0	334	1.6	10	4285		
	93.3	484	1.2	15	4905		
	70.0	638	0.9	20	5399		
	<b>PMRV110 - 132S/4C</b>	186.7	253	2.2	7.5	3893	79
		140.0	334	1.8	10	4285	
		93.3	484	1.4	15	4905	
		70.0	638	1.0	20	5399	
	<b>PMRV130 - 132S/4C</b>	140.0	334	2.5	10	5605	80
		93.3	490	1.9	15	6416	
		70.0	645	1.4	20	7062	
		56.0	788	1.2	25	7607	
		46.7	900	1.2	30	8084	
		35.0	1171	0.9	40	8897	

P <sub>1</sub> [kW]	n <sub>2</sub> [Min <sup>-1</sup> ]	M <sub>2</sub> [Nm]	f <sub>B</sub>	i <sub>ges</sub>	F <sub>R</sub> [N]	Tip / Type / Typ Tipo / Type / Tipo	 mm
<b>5.50</b>	70.0	645	2.0	20	9654	<b>PMRV150 - 132S/4C</b>	81
	56.0	788	1.5	25	10400		
	46.7	934	1.3	30	11051		
	35.0	1171	1.3	40	12163		
	28.0	1426	1.0	50	13103		
	23.3	1643	0.8	60	13924		
<b>7.50</b>	186.7	345	1.4	7.5	3893	<b>PMRV105 - 132M/4B</b>	78
	140.0	455	1.1	10	4285		
	93.3	660	0.9	15	4905		
	186.7	345	1.6	7.5	3893	<b>PMRV110 - 132M/4B</b>	79
	140.0	455	1.3	10	4285		
	93.3	660	1.0	15	4905		
	186.7	349	2.1	7.5	5092	<b>PMRV130 - 132M/4B</b>	80
	140.0	455	1.8	10	5605		
	93.3	668	1.4	15	6416		
	70.0	880	1.0	20	7062		
	56.0	1074	0.9	25	7607		
	46.7	1228	0.8	30	8084		
35.0	1596	0.7	40	8897			
70.0	880	1.5	20	9654	<b>PMRV150 - 132M/4B</b>	81	
56.0	1074	1.1	25	10400			
46.7	1274	0.9	30	11051			
35.0	1596	1.0	40	12163			
<b>9.20</b>	186.7	424	1.3	7.5	3893	<b>PMRV110 - 132M/4</b>	79
	186.7	428	1.8	7.5	5092	<b>PMRV130 - 132M/4</b>	80
	140.0	559	1.5	10	5605		
	93.3	819	1.1	15	6416		
	70.0	1079	0.8	20	7062		
	56.0	1318	0.7	25	7607		
	70.0	1079	1.2	20	9654	<b>PMRV150 - 132M/4</b>	81
	56.0	1318	0.9	25	10400		
46.7	1563	0.8	30	11051			
35.0	1958	0.8	40	12163			
<b>11.0</b>	186.7	512	2.3	7.5	6962	<b>PMRV150 - 160M/4B</b>	81
	140.0	675	1.8	10	7663		
	93.3	990	1.3	15	8771		
	70.0	1291	1.0	20	9654		
	56.0	1576	0.8	25	10400		
<b>15.0</b>	186.7	698	1.7	7.5	6962	<b>PMRV150 - 160L/4A</b>	81
	140.0	921	1.3	10	7663		
	93.3	1351	0.9	15	8771		
	70.0	1760	0.7	20	9654		

(n1=2800 min<sup>-1</sup>)

P <sub>1</sub> [kW]	n <sub>2</sub> [Min <sup>-1</sup> ]	M <sub>2</sub> [Nm]	i <sub>ges</sub>	F <sub>r1</sub> [N]	F <sub>r2</sub> [N]	Tip / Type / Typ Tipo / Type / Tipo			
0.79	560.0	12	5	115	474	PRV030	93		
0.58	373.3	13	7.5	125	542				
0.45	280.0	13	10	140	597				
0.31	186.7	13	15	140	683				
0.23	140.0	12	20	146	752				
0.25	112.0	16	25	210	810				
0.21	93.3	15	30	210	861				
0.16	70.0	14	40	127	948				
0.12	56.0	13	50	128	1021				
0.10	46.7	12	60	126	1085				
0.08	35.0	11	80	130	1194				
1.6	560.0	24	5	200	912	PRV040	93		
1.2	373.3	28	7.5	233	1044				
1.0	280.0	29	10	272	1149				
0.72	186.7	31	15	291	1315				
0.52	140.0	29	20	204	1447				
0.42	112.0	28	25	236	1559				
0.44	93.3	34	30	350	1657				
0.32	70.0	31	40	350	1824				
0.26	56.0	30	50	350	1964				
0.21	46.7	28	60	350	2087				
0.16	35.0	25	80	350	2298				
0.12	28.0	23	100	350	2475				
2.9	560.0	45	5	280	1251			PRV050	93
2.3	373.3	52	7.5	324	1433				
1.8	280.0	54	10	378	1577				
1.3	186.7	57	15	399	1805				
0.95	140.0	53	20	417	1987				
0.75	112.0	51	25	482	2140				
0.82	93.3	64	30	490	2274				
0.59	70.0	59	40	490	2503				
0.45	56.0	53	50	490	2696				
0.37	46.7	50	60	490	2865				
0.27	35.0	45	80	490	3153				
0.21	28.0	40	100	490	3397				
4.0	373.3	93	7.5	395	1873	PRV063	93		
3.2	280.0	97	10	463	2061				
2.3	186.7	103	15	492	2359				
1.7	140.0	100	20	538	2597				
1.3	112.0	92	25	593	2797				
1.5	93.3	120	30	700	2973				
1.1	70.0	108	40	700	3272				
0.83	56.0	100	50	700	3524				
0.68	46.7	95	60	700	3745				
0.49	35.0	85	80	700	4122				
0.37	28.0	74	100	700	4440				
5.6	373.3	130	7.5	560	2210			PRV075	93
4.7	280.0	145	10	703	2433				
3.4	186.7	150	15	727	2785				
2.8	140.0	160	20	872	3065				
2.1	112.0	150	25	980	3302				
2.1	93.3	170	30	980	3509				
1.6	70.0	165	40	980	3862				
1.2	56.0	150	50	980	4160				
1.0	46.7	145	60	980	4421				
0.72	35.0	130	80	980	4865				
0.58	28.0	120	100	980	5241				

(n1=2800 min-1)

<b>P1</b> <b>[kW]</b>	<b>n2</b> <b>[Min<sup>-1</sup>]</b>	<b>M2</b> <b>[Nm]</b>	<b>iges</b>	<b>Fr1</b> <b>[N]</b>	<b>Fr2</b> <b>[N]</b>	<b>Tip / Type / Typ</b> <b>Tipo / Type / Tipo</b>	 <b>mm</b>
8.9	373.3	<b>210</b>	7.5	715	2446	<b>PRV090</b>	93
7.7	280.0	<b>235</b>	10	900	2692		
6.0	186.7	<b>270</b>	15	1034	3081		
4.4	140.0	<b>260</b>	20	1120	3391		
3.4	112.0	<b>250</b>	25	1270	3653		
3.7	93.3	<b>310</b>	30	1270	3882		
2.6	70.0	<b>275</b>	40	1270	4273		
2.0	56.0	<b>265</b>	50	1270	4603		
1.6	46.7	<b>245</b>	60	1270	4891		
1.2	35.0	<b>225</b>	80	1270	5383		
0.9	28.0	<b>200</b>	100	1270	5799		
14.4	373.3	<b>340</b>	7.5	950	3090	<b>PRV105</b>	93
12.2	280.0	<b>380</b>	10	1194	3401		
9.3	186.7	<b>425</b>	15	1336	3893		
7.0	140.0	<b>420</b>	20	1485	4285		
5.9	112.0	<b>440</b>	25	1700	4616		
5.7	93.3	<b>480</b>	30	1700	4905		
4.1	70.0	<b>460</b>	40	1700	5399		
3.3	56.0	<b>450</b>	50	1700	5816		
2.7	46.7	<b>430</b>	60	1700	6181		
1.9	35.0	<b>380</b>	80	1700	6803		
1.5	28.0	<b>350</b>	100	1700	7328		
16.6	373.3	<b>391</b>	7.5	950	3090	<b>PRV110</b>	93
14.1	280.0	<b>437</b>	10	1194	3401		
10.7	186.7	<b>489</b>	15	1337	3893		
8.0	140.0	<b>483</b>	20	1485	4285		
6.8	112.0	<b>506</b>	25	1700	4616		
6.5	93.3	<b>552</b>	30	1700	4905		
4.7	70.0	<b>529</b>	40	1700	5399		
3.7	56.0	<b>495</b>	50	1700	5816		
3.0	46.7	<b>473</b>	60	1700	6181		
2.0	35.0	<b>399</b>	80	1700	6803		
1.6	28.0	<b>368</b>	100	1700	7328		
22.1	373.3	<b>520</b>	7.5	1190	4042	<b>PRV130</b>	93
18.7	280.0	<b>580</b>	10	1493	4449		
14.7	186.7	<b>670</b>	15	1725	5092		
11.0	140.0	<b>660</b>	20	1912	5605		
9.0	112.0	<b>670</b>	25	2100	6038		
9.0	93.3	<b>770</b>	30	2100	6416		
6.5	70.0	<b>730</b>	40	2100	7062		
5.1	56.0	<b>700</b>	50	2100	7607		
4.0	46.7	<b>640</b>	60	2100	8084		
3.0	35.0	<b>590</b>	80	2100	8897		
2.2	28.0	<b>520</b>	100	2100	9584		
35.7	373.3	<b>840</b>	7.5	1550	5526	<b>PRV150</b>	93
28.4	280.0	<b>890</b>	10	1848	6082		
19.8	186.7	<b>910</b>	15	1889	6962		
16.1	140.0	<b>980</b>	20	2289	7663		
12.0	112.0	<b>890</b>	25	2494	8254		
10.5	93.3	<b>920</b>	30	2800	8771		
10.6	70.0	<b>1200</b>	40	2800	9654		
8.1	56.0	<b>1100</b>	50	2800	10400		
6.2	46.7	<b>990</b>	60	2800	11051		
4.6	35.0	<b>920</b>	80	2800	12163		
3.3	28.0	<b>810</b>	100	2800	13103		

(n1=1400 min<sup>-1</sup>)

P <sub>1</sub> [kW]	n <sub>2</sub> [Min <sup>-1</sup> ]	M <sub>2</sub> [Nm]	iges	F <sub>r1</sub> [N]	F <sub>r2</sub> [N]	Tip / Type / Typ Tipo / Type / Tipo	 mm
0.61	280.0	18	5	150	597	PRV030	93
0.41	186.7	18	7.5	150	683		
0.32	140.0	18	10	169	752		
0.23	93.3	18	15	169	861		
0.18	70.0	18	20	190	948		
0.18	56.0	21	25	210	1021		
0.15	46.7	20	30	210	1085		
0.11	35.0	18	40	210	1194		
0.09	28.0	17	50	210	1286		
0.08	23.3	16	60	210	1367		
0.05	17.5	13	80	210	1504		
1.1	280.0	34	5	250	1149	PRV040	93
0.90	186.7	40	7.5	294	1315		
0.69	140.0	40	10	331	1447		
0.48	93.3	40	15	331	1657		
0.37	70.0	39	20	350	1824		
0.30	56.0	38	25	350	1964		
0.31	46.7	45	30	350	2087		
0.23	35.0	41	40	350	2298		
0.18	28.0	39	50	350	2475		
0.15	23.3	36	60	350	2630		
0.12	17.5	33	80	350	2895		
0.09	14.0	29	100	350	3118		
2.0	280.0	62	5	350	1577	PRV050	93
1.6	186.7	71	7.5	401	1805		
1.2	140.0	72	10	490	1987		
0.88	93.3	74	15	490	2274		
0.68	70.0	73	20	490	2503		
0.54	56.0	70	25	490	2696		
0.57	46.7	84	30	490	2865		
0.42	35.0	76	40	490	3153		
0.34	28.0	73	50	490	3397		
0.28	23.3	68	60	490	3610		
0.22	17.5	65	80	490	3973		
0.16	14.0	55	100	490	4280		
2.8	186.7	128	7.5	500	2359	PRV063	93
2.2	140.0	130	10	571	2597		
1.6	93.3	140	15	615	2973		
1.2	70.0	135	20	667	3272		
1.0	56.0	130	25	700	3524		
1.1	46.7	160	30	700	3745		
0.76	35.0	145	40	700	4122		
0.60	28.0	135	50	700	4440		
0.51	23.3	130	60	700	4719		
0.39	17.5	122	80	700	5193		
0.34	14.0	118	100	700	5595		
4.1	186.7	185	7.5	700	2785	PRV075	93
3.2	140.0	195	10	830	3065		
2.3	93.3	200	15	851	3509		
1.9	70.0	210	20	980	3862		
1.5	56.0	200	25	980	4160		
1.5	46.7	230	30	980	4421		
1.1	35.0	220	40	980	4865		
0.89	28.0	210	50	980	5241		
0.75	23.3	200	60	980	5569		
0.58	17.5	190	80	980	6130		
0.48	14.0	180	100	980	6603		

(n1=1400 min-1)

P1 [kW]	n2 [Min <sup>-1</sup> ]	M2 [Nm]	iges	Fr1 [N]	Fr2 [N]	Tip / Type / Typ Tipo / Type / Tipo	
6.3	186.7	<b>290</b>	7.5	900	3081	<b>PRV090</b>	93
5.1	140.0	<b>310</b>	10	1082	3391		
4.1	93.3	<b>360</b>	15	1257	3882		
3.1	70.0	<b>355</b>	20	1270	4273		
2.4	56.0	<b>340</b>	25	1270	4603		
2.6	46.7	<b>410</b>	30	1270	4891		
1.8	35.0	<b>360</b>	40	1270	5383		
1.4	28.0	<b>340</b>	50	1270	5799		
1.1	23.3	<b>320</b>	60	1270	6163		
0.83	17.5	<b>285</b>	80	1270	6783		
0.67	14.0	<b>270</b>	100	1270	7306		
10.4	186.7	<b>480</b>	7.5	1200	3893	<b>PRV105</b>	93
8.6	140.0	<b>520</b>	10	1463	4285		
6.5	93.3	<b>570</b>	15	1603	4905		
4.8	70.0	<b>560</b>	20	1700	5399		
4.1	56.0	<b>590</b>	25	1700	5816		
3.9	46.7	<b>630</b>	30	1700	6181		
2.9	35.0	<b>610</b>	40	1700	6803		
2.3	28.0	<b>600</b>	50	1700	7328		
1.9	23.3	<b>560</b>	60	1700	7787		
1.3	17.5	<b>490</b>	80	1700	8571		
1.1	14.0	<b>460</b>	100	1700	9232		
12.0	186.7	<b>552</b>	7.5	1200	3893	<b>PRV110</b>	93
9.8	140.0	<b>598</b>	10	1463	4285		
7.5	93.3	<b>656</b>	15	1604	4905		
5.6	70.0	<b>644</b>	20	1700	5399		
4.7	56.0	<b>679</b>	25	1700	5816		
4.5	46.7	<b>725</b>	30	1700	6181		
3.3	35.0	<b>702</b>	40	1700	6803		
2.6	28.0	<b>660</b>	50	1700	7328		
2.1	23.3	<b>616</b>	60	1700	7787		
1.4	17.5	<b>515</b>	80	1700	8571		
1.1	14.0	<b>483</b>	100	1700	9232		
16.1	186.7	<b>750</b>	7.5	1500	5092	<b>PRV130</b>	93
13.5	140.0	<b>820</b>	10	1845	5605		
10.3	93.3	<b>920</b>	15	2070	6416		
7.8	70.0	<b>910</b>	20	2100	7062		
6.5	56.0	<b>930</b>	25	2100	7607		
6.4	46.7	<b>1040</b>	30	2100	8084		
4.9	35.0	<b>1050</b>	40	2100	8897		
3.8	28.0	<b>980</b>	50	2100	9584		
3.1	23.3	<b>900</b>	60	2100	10185		
2.3	17.5	<b>840</b>	80	2100	11210		
1.7	14.0	<b>740</b>	100	2100	12076		
25.8	186.7	<b>1200</b>	7.5	1950	6962	<b>PRV150</b>	93
20.2	140.0	<b>1240</b>	10	2267	7663		
13.9	93.3	<b>1250</b>	15	2285	8771		
11.1	70.0	<b>1300</b>	20	2674	9654		
8.4	56.0	<b>1200</b>	25	2800	10400		
7.1	46.7	<b>1200</b>	30	2800	11051		
7.3	35.0	<b>1550</b>	40	2800	12163		
5.4	28.0	<b>1400</b>	50	2800	13103		
4.2	23.3	<b>1260</b>	60	2800	13924		
3.1	17.5	<b>1150</b>	80	2800	15325		
2.3	14.0	<b>1000</b>	100	2800	16508		

(n1=900 min-1)

P <sub>1</sub> [kW]	n <sub>2</sub> [Min <sup>-1</sup> ]	M <sub>2</sub> [Nm]	i <sub>ges</sub>	F <sub>r1</sub> [N]	F <sub>r2</sub> [N]	Tip / Type / Typ Tipo / Type / Tipo	 mm
0.44	180.0	20	5	175	692	PRV030	93
0.30	120.0	20	7.5	175	792		
0.24	90.0	20	10	197	871		
0.17	60.0	20	15	197	997		
0.13	45.0	20	20	210	1098		
0.14	36.0	23	25	210	1183		
0.11	30.0	21	30	210	1257		
0.09	22.5	20	40	210	1383		
0.07	18.0	18	50	210	1490		
0.06	15.0	17	60	210	1583		
0.04	11.3	15	80	210	1743		
0.87	180.0	40	5	290	1331	PRV040	93
0.65	120.0	44	7.5	319	1524		
0.50	90.0	44	10	350	1677		
0.36	60.0	45	15	350	1920		
0.28	45.0	44	20	350	2113		
0.23	36.0	43	25	350	2276		
0.23	30.0	49	30	350	2419		
0.17	22.5	45	40	350	2662		
0.14	18.0	42	50	350	2868		
0.11	15.0	39	60	350	3047		
0.09	11.3	35	80	350	3354		
0.07	9.0	32	100	350	3490		
1.6	180.0	75	5	400	1827	PRV050	93
1.2	120.0	84	7.5	448	2091		
0.94	90.0	84	10	490	2302		
0.67	60.0	84	15	490	2635		
0.48	45.0	77	20	490	2900		
0.39	36.0	75	25	490	3124		
0.42	30.0	90	30	490	3320		
0.31	22.5	82	40	490	3654		
0.25	18.0	77	50	490	3936		
0.21	15.0	72	60	490	4183		
0.16	11.3	68	80	490	4604		
0.12	9.0	56	100	490	4840		
2.2	120.0	151	7.5	580	2734	PRV063	93
1.7	90.0	153	10	661	3009		
1.2	60.0	155	15	670	3444		
0.91	45.0	148	20	700	3791		
0.69	36.0	137	25	700	4084		
0.79	30.0	175	30	700	4339		
0.58	22.5	160	40	700	4776		
0.45	18.0	145	50	700	5145		
0.37	15.0	138	60	700	5467		
0.29	11.3	128	80	700	6018		
0.25	9.0	124	100	700	6270		
3.1	120.0	215	7.5	810	3227	PRV075	93
2.5	90.0	230	10	975	3551		
1.8	60.0	235	15	980	4065		
1.4	45.0	235	20	980	4474		
1.1	36.0	215	25	980	4820		
1.1	30.0	260	30	980	5122		
0.83	22.5	240	40	980	5637		
0.65	18.0	220	50	980	6073		
0.54	15.0	210	60	980	6453		
0.43	11.3	200	80	980	7103		
0.36	9.0	190	100	980	7380		



(n1=900 min<sup>-1</sup>)

P <sub>1</sub> [kW]	n <sub>2</sub> [Min <sup>-1</sup> ]	M <sub>2</sub> [Nm]	i <sub>ges</sub>	F <sub>r1</sub> [N]	F <sub>r2</sub> [N]	Tip / Type / Typ Tipo / Type / Tipo	
4.8	120.0	<b>340</b>	7.5	1040	3570	<b>PRV090</b>	93
4.0	90.0	<b>370</b>	10	1270	3929		
3.1	60.0	<b>420</b>	15	1270	4498		
2.3	45.0	<b>390</b>	20	1270	4951		
1.8	36.0	<b>370</b>	25	1270	5333		
1.9	30.0	<b>460</b>	30	1270	5667		
1.4	22.5	<b>410</b>	40	1270	6238		
1.1	18.0	<b>390</b>	50	1270	6719		
0.86	15.0	<b>350</b>	60	1270	7140		
0.63	11.3	<b>315</b>	80	1270	7859		
0.49	9.0	<b>280</b>	100	1270	8180		
8.0	120.0	<b>565</b>	7.5	1390	4511	<b>PRV105</b>	93
6.6	90.0	<b>620</b>	10	1700	4965		
4.9	60.0	<b>660</b>	15	1700	5684		
3.6	45.0	<b>630</b>	20	1700	6256		
3.1	36.0	<b>660</b>	25	1700	6739		
3.0	30.0	<b>730</b>	30	1700	7161		
2.2	22.5	<b>690</b>	40	1700	7882		
1.8	18.0	<b>680</b>	50	1700	8491		
1.4	15.0	<b>620</b>	60	1700	9023		
1.0	11.3	<b>540</b>	80	1700	9931		
0.8	9.0	<b>490</b>	100	1700	10320		
9.2	120.0	<b>650</b>	7.5	1390	4511	<b>PRV110</b>	93
7.6	90.0	<b>713</b>	10	1700	4965		
5.6	60.0	<b>759</b>	15	1700	5684		
4.1	45.0	<b>725</b>	20	1700	6256		
3.5	36.0	<b>759</b>	25	1700	6739		
3.5	30.0	<b>840</b>	30	1700	7161		
2.5	22.5	<b>794</b>	40	1700	7882		
2.0	18.0	<b>748</b>	50	1700	8491		
1.6	15.0	<b>682</b>	60	1700	9023		
1.1	11.3	<b>567</b>	80	1700	9931		
0.84	9.0	<b>515</b>	100	1700	10320		
12.3	120.0	<b>880</b>	7.5	1740	5901	<b>PRV130</b>	93
10.3	90.0	<b>960</b>	10	2100	6494		
7.8	60.0	<b>1060</b>	15	2100	7434		
5.8	45.0	<b>1040</b>	20	2100	8182		
4.8	36.0	<b>1050</b>	25	2100	8814		
4.7	30.0	<b>1170</b>	30	2100	9366		
3.5	22.5	<b>1100</b>	40	2100	10309		
2.7	18.0	<b>1050</b>	50	2100	11105		
2.1	15.0	<b>940</b>	60	2100	11801		
1.6	11.3	<b>860</b>	80	2100	12989		
1.2	9.0	<b>780</b>	100	2100	13500		
19.5	120.0	<b>1400</b>	7.5	2270	8067	<b>PRV150</b>	93
15.7	90.0	<b>1480</b>	10	2700	8878		
10.5	60.0	<b>1450</b>	15	2645	10163		
8.4	45.0	<b>1500</b>	20	2800	11186		
6.3	36.0	<b>1380</b>	25	2800	12050		
5.4	30.0	<b>1400</b>	30	2800	12805		
5.7	22.5	<b>1800</b>	40	2800	14094		
4.1	18.0	<b>1600</b>	50	2800	15182		
3.2	15.0	<b>1440</b>	60	2800	16133		
2.4	11.3	<b>1300</b>	80	2800	17757		
1.8	9.0	<b>1150</b>	100	2800	18000		

(n1=500 min-1)

P <sub>1</sub> [kW]	n <sub>2</sub> [Min <sup>-1</sup> ]	M <sub>2</sub> [Nm]	i <sub>ges</sub>	F <sub>r1</sub> [N]	F <sub>r2</sub> [N]	Tip / Type / Typ Tipo / Type / Tipo	
0.30	100.0	<b>24</b>	5	210	841	<b>PRV030</b>	93
0.21	66.7	<b>24</b>	7.5	210	963		
0.16	50.0	<b>24</b>	10	210	1060		
0.12	33.3	<b>24</b>	15	210	1213		
0.09	25.0	<b>23</b>	20	210	1336		
0.10	20.0	<b>29</b>	25	210	1439		
0.08	16.7	<b>26</b>	30	210	1529		
0.06	12.5	<b>23</b>	40	210	1683		
0.05	10.0	<b>21</b>	50	210	1813		
0.04	8.3	<b>19</b>	60	210	1830		
0.03	6.3	<b>17</b>	80	210	1830		
0.60	100.0	<b>49</b>	5	350	1619	<b>PRV040</b>	93
0.45	66.7	<b>54</b>	7.5	350	1853		
0.35	50.0	<b>54</b>	10	350	2040		
0.26	33.3	<b>55</b>	15	350	2335		
0.19	25.0	<b>52</b>	20	350	2570		
0.15	20.0	<b>49</b>	25	350	2769		
0.16	16.7	<b>58</b>	30	350	2942		
0.12	12.5	<b>53</b>	40	350	3238		
0.10	10.0	<b>49</b>	50	350	3488		
0.08	8.3	<b>46</b>	60	350	3490		
0.06	6.3	<b>40</b>	80	350	3490		
0.05	5.0	<b>36</b>	100	350	3490		
1.1	100.0	<b>92</b>	5	490	2222	<b>PRV050</b>	93
0.86	66.7	<b>103</b>	7.5	490	2544		
0.67	50.0	<b>103</b>	10	490	2800		
0.47	33.3	<b>103</b>	15	490	3205		
0.33	25.0	<b>93</b>	20	490	3528		
0.28	20.0	<b>91</b>	25	490	3800		
0.29	16.7	<b>108</b>	30	490	4038		
0.22	12.5	<b>98</b>	40	490	4445		
0.17	10.0	<b>91</b>	50	490	4788		
0.14	8.3	<b>83</b>	60	490	4840		
0.11	6.3	<b>75</b>	80	490	4840		
0.09	5.0	<b>65</b>	100	490	4840		
1.5	66.7	<b>184</b>	7.5	700	3325	<b>PRV063</b>	93
1.2	50.0	<b>185</b>	10	700	3660		
0.85	33.3	<b>187</b>	15	700	4190		
0.63	25.0	<b>178</b>	20	700	4611		
0.48	20.0	<b>164</b>	25	700	4967		
0.54	16.7	<b>200</b>	30	700	5279		
0.40	12.5	<b>185</b>	40	700	5810		
0.32	10.0	<b>173</b>	50	700	6259		
0.26	8.3	<b>160</b>	60	700	6270		
0.19	6.3	<b>137</b>	80	700	6270		
0.16	5.0	<b>128</b>	100	700	6270		
2.1	66.7	<b>260</b>	7.5	980	3925		
1.7	50.0	<b>270</b>	10	980	4320		
1.2	33.3	<b>280</b>	15	980	4945		
0.98	25.0	<b>285</b>	20	980	5443		
0.73	20.0	<b>255</b>	25	980	5863		
0.77	16.7	<b>300</b>	30	980	6231		
0.58	12.5	<b>280</b>	40	980	6858		
0.44	10.0	<b>250</b>	50	980	7380		
0.37	8.3	<b>240</b>	60	980	7380		
0.29	6.3	<b>215</b>	80	980	7380		
0.24	5.0	<b>210</b>	100	980	7380		

(n1=500 min-1)

P <sub>1</sub> [kW]	n <sub>2</sub> [Min <sup>-1</sup> ]	M <sub>2</sub> [Nm]	i <sub>ges</sub>	F <sub>r1</sub> [N]	F <sub>r2</sub> [N]	Tip / Type / Typ Tipo / Type / Tipo	 mm
3.3	66.7	410	7.5	1270	4343	PRV090	93
2.7	50.0	435	10	1270	4780		
2.1	33.3	490	15	1270	5472		
1.6	25.0	470	20	1270	6022		
1.2	20.0	440	25	1270	6487		
1.4	16.7	550	30	1270	6894		
0.95	12.5	480	40	1270	7588		
0.75	10.0	450	50	1270	8174		
0.59	8.3	400	60	1270	8180		
0.45	6.3	365	80	1270	8180		
0.35	5.0	330	100	1270	8180		
5.5	66.7	690	7.5	1700	5488		
4.6	50.0	740	10	1700	6040		
3.4	33.3	790	15	1700	6914		
2.5	25.0	750	20	1700	7610		
2.1	20.0	790	25	1700	8198		
2.1	16.7	870	30	1700	8711		
1.5	12.5	810	40	1700	9588		
1.3	10.0	800	50	1700	10320		
0.98	8.3	710	60	1700	10320		
0.72	6.3	630	80	1700	10320		
0.56	5.0	570	100	1700	10320		
6.4	66.7	794	7.5	1700	5488	PRV110	93
5.2	50.0	851	10	1700	6040		
3.9	33.3	909	15	1700	6914		
2.8	25.0	863	20	1700	7610		
2.4	20.0	909	25	1700	8198		
2.4	16.7	1000	30	1700	8711		
1.7	12.5	932	40	1700	9588		
1.4	10.0	880	50	1700	10320		
1.1	8.3	781	60	1700	10320		
0.76	6.3	662	80	1700	10320		
0.59	5.0	599	100	1700	10320		
8.6	66.7	1080	7.5	2100	7178		
7.1	50.0	1160	10	2100	7900		
5.5	33.3	1300	15	2100	9043		
4.0	25.0	1230	20	2100	9953		
3.2	20.0	1200	25	2100	10722		
3.3	16.7	1400	30	2100	11394		
2.4	12.5	1300	40	2100	12540		
1.9	10.0	1220	50	2100	13500		
1.5	8.3	1070	60	2100	13500		
1.1	6.3	970	80	2100	13500		
0.85	5.0	860	100	2100	13500		
13.5	66.7	1700	7.5	2800	9812	PRV150	93
10.7	50.0	1780	10	2800	10800		
7.2	33.3	1730	15	2800	12363		
5.9	25.0	1820	20	2800	13607		
4.3	20.0	1630	25	2800	14658		
3.8	16.7	1670	30	2800	15576		
3.9	12.5	2120	40	2800	17144		
2.9	10.0	1870	50	2800	18000		
2.3	8.3	1680	60	2800	18000		
1.7	6.3	1530	80	2800	18000		
1.3	5.0	1350	100	2800	18000		

PRV/PMRV (n1=1400 min-1)

P <sub>1</sub> [kW]	n <sub>2</sub> [Min <sup>-1</sup> ]	M <sub>2</sub> [Nm]	i <sub>ges</sub>	F <sub>r1</sub> [N]	F <sub>r2</sub> [N]	Tip / Type / Typ Tipo / Type / Tipo	 mm
0.08	4.7	73	300	210	3490	PRV030/040	87
0.06	3.5	65	400	210	3490		
0.04	2.8	61	500	210	3490		
0.04	2.3	73	600	210	3490		
0.04	1.9	73	750	210	3490		
0.03	1.6	73	900	210	3490		
0.02	1.2	65	1200	210	3490		
0.02	0.9	73	1500	210	3490		
0.02	0.8	73	1800	210	3490		
0.01	0.58	65	2400	210	3490		
0.01	0.4	65	3200	210	3490		
0.01	0.4	33	4000	210	3490		
0.01	0.28	29	5000	210	3490		
0.15	4.7	145	300	210	4840		
0.10	3.5	124	400	210	4840		
0.09	2.8	120	500	210	4840		
0.08	2.3	145	600	210	4840		
0.07	1.9	145	750	210	4840		
0.06	1.6	145	900	210	4840		
0.04	1.2	124	1200	210	4840		
0.04	0.93	145	1500	210	4840		
0.04	0.78	145	1800	210	4840		
0.03	0.6	124	2400	210	4840		
0.02	0.5	120	3000	210	4840		
0.02	0.35	82	4000	210	4840		
0.02	0.29	82	4800	210	4840		
0.24	4.7	230	300	210	6270	PRV030/063	88
0.19	3.5	230	400	210	6270		
0.15	2.8	216	500	210	6270		
0.13	2.3	230	600	210	6270		
0.11	1.9	216	750	210	6270		
0.09	1.6	198	900	210	6270		
0.08	1.2	230	1200	210	6270		
0.06	0.93	216	1500	210	6270		
0.05	0.78	198	1800	210	6270		
0.05	0.58	230	2400	210	6270		
0.04	0.47	216	3000	210	6270		
0.03	0.35	172	4000	210	6270		
0.02	0.28	150	5000	210	6270		
0.36	4.7	390	300	350	7380		
0.27	3.5	360	400	350	7380		
0.21	2.8	320	500	350	7380		
0.19	2.3	390	600	350	7380		
0.16	1.9	390	750	350	7380		
0.14	1.6	390	900	350	7380		
0.11	1.2	360	1200	350	7380		
0.10	0.93	390	1500	350	7380		
0.09	0.78	390	1800	350	7380		
0.07	0.58	360	2400	350	7380		
0.05	0.47	320	3000	350	7380		
0.04	0.35	250	4000	350	7380		
0.03	0.28	230	5000	350	7380		
0.56	4.7	610	300	350	8180	PRV040/090	88
0.43	3.5	610	400	350	8180		
0.34	2.8	560	500	350	8180		
0.30	2.3	610	600	350	8180		
0.23	1.9	560	750	350	8180		
0.19	1.6	505	900	350	8180		
0.17	1.2	610	1200	350	8180		
0.14	0.93	560	1500	350	8180		

**PRV/PMRV (n1=1400 min-1)**

<b>P<sub>1</sub></b> [kW]	<b>n<sub>2</sub></b> [Min <sup>-1</sup> ]	<b>M<sub>2</sub></b> [Nm]	<b>i<sub>ges</sub></b>	<b>F<sub>r1</sub></b> [N]	<b>F<sub>r2</sub></b> [N]	<b>Tip / Type / Typ</b> <b>Tipo / Type / Tipo</b>	 mm
0.11	0.78	<b>505</b>	1800	350	8180	<b>PRV040/090</b>	88
0.11	0.58	<b>610</b>	2400	350	8180		
0.08	0.47	<b>560</b>	3000	350	8180		
0.08	0.35	<b>460</b>	4000	350	8180		
0.06	0.28	<b>410</b>	5000	350	8180		
0.95	4.7	<b>1100</b>	300	490	10320	<b>PRV050/105</b>	89
0.69	3.5	<b>1030</b>	400	490	10320		
0.56	2.8	<b>1000</b>	500	490	10320		
0.48	2.3	<b>1030</b>	600	490	10320		
0.43	1.9	<b>1100</b>	750	490	10320		
0.38	1.6	<b>1100</b>	900	490	10320		
0.27	1.2	<b>1030</b>	1200	490	10320		
0.26	0.93	<b>1100</b>	1500	490	10320		
0.23	0.78	<b>1100</b>	1800	490	10320		
0.17	0.58	<b>1030</b>	2400	490	10320		
0.14	0.47	<b>1000</b>	3000	490	10320		
0.12	0.35	<b>780</b>	4000	490	10320		
0.09	0.28	<b>710</b>	5000	490	10320		
1.1	4.7	<b>1265</b>	300	490	10320	<b>PRV050/110</b>	89
0.79	3.5	<b>1185</b>	400	490	10320		
0.61	2.8	<b>1100</b>	500	490	10320		
0.55	2.3	<b>1185</b>	600	490	10320		
0.49	1.9	<b>1265</b>	750	490	10320		
0.43	1.6	<b>1265</b>	900	490	10320		
0.31	1.2	<b>1185</b>	1200	490	10320		
0.30	0.93	<b>1265</b>	1500	490	10320		
0.26	0.78	<b>1265</b>	1800	490	10320		
0.19	0.58	<b>1185</b>	2400	490	10320		
0.15	0.47	<b>1100</b>	3000	490	10320		
0.13	0.35	<b>819</b>	4000	490	10320		
0.10	0.28	<b>746</b>	5000	490	10320		
1.5	4.7	<b>1760</b>	300	700	13500	<b>PRV063/130</b>	89
1.1	3.5	<b>1650</b>	400	700	13500		
0.86	2.8	<b>1550</b>	500	700	13500		
0.76	2.3	<b>1650</b>	600	700	13500		
0.66	1.9	<b>1760</b>	750	700	13500		
0.58	1.6	<b>1760</b>	900	700	13500		
0.43	1.2	<b>1650</b>	1200	700	13500		
0.39	0.93	<b>1760</b>	1500	700	13500		
0.35	0.78	<b>1760</b>	1800	700	13500		
0.25	0.58	<b>1650</b>	2400	700	13500		
0.20	0.47	<b>1550</b>	3000	700	13500		
0.15	0.35	<b>1220</b>	4000	700	13500		
0.11	0.28	<b>1100</b>	5000	700	13500		
3.4	9.3	<b>2340</b>	150	700	18000	<b>PRV063/150</b>	90
2.7	7.0	<b>2340</b>	200	700	18000		
1.9	5.6	<b>2050</b>	250	700	18000		
1.9	4.7	<b>2340</b>	300	700	18000		
1.8	3.5	<b>2670</b>	400	700	18000		
1.4	2.8	<b>2330</b>	500	700	18000		
1.3	2.3	<b>2670</b>	600	700	18000		
0.98	1.9	<b>2330</b>	750	700	18000		
0.71	1.6	<b>2100</b>	900	700	18000		
0.75	1.2	<b>2670</b>	1200	700	18000		
0.44	0.8	<b>2100</b>	1800	700	18000		
0.46	0.6	<b>2670</b>	2400	700	18000		
0.34	0.5	<b>2330</b>	3000	700	18000		
0.23	0.4	<b>1880</b>	4000	700	18000		
0.18	0.3	<b>1650</b>	5000	700	18000		



A large area of the page is filled with horizontal dotted lines, serving as a template for writing or drawing.

Ölçü Tabloları

Dimensions

Abmessungen

Dimensioni

Encombrements

Dimensiones

**PMRV**  
**030...150**

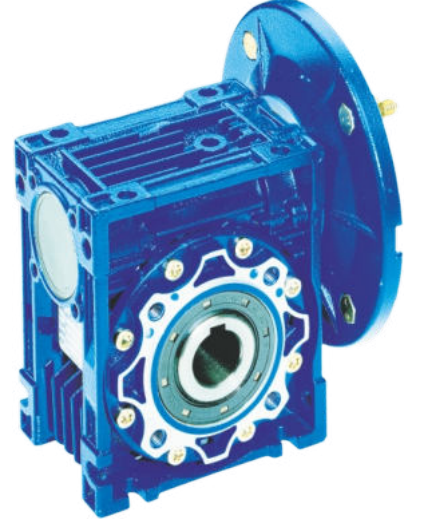

**PRV**  
**030...150**



**PMRV / PRV**



A large area of the page is filled with horizontal dotted lines, serving as a template for writing or drawing.



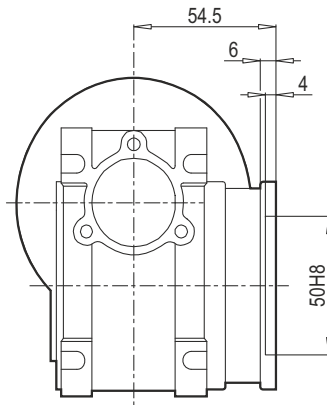
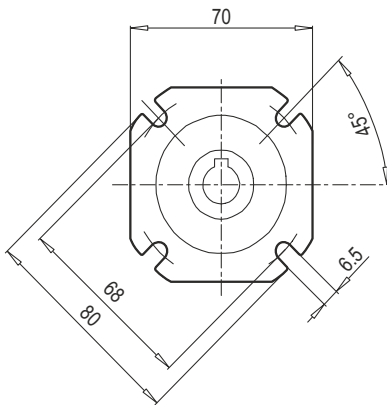
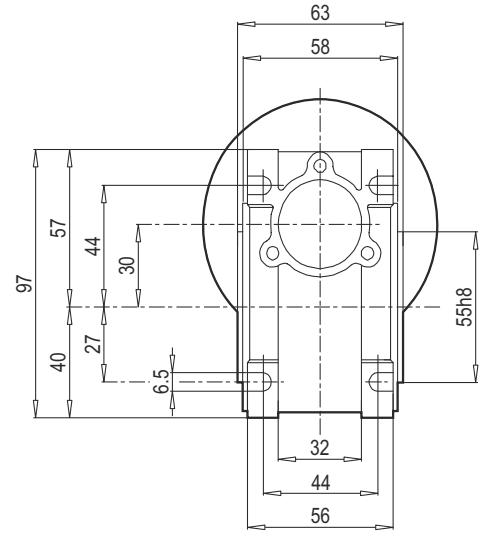
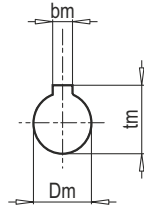
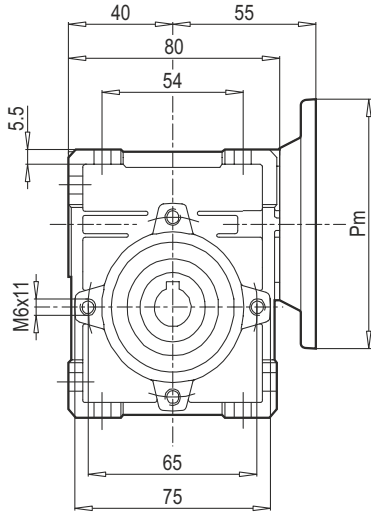

**FA**

- Motorsuz ağırlık ~1.2 kg
- Weight without motor ~1.2 kg
- Gewicht ohne motor ~1.2 kg
- Peso senza motore ~1.2 kg
- Poids sans moteur ~1.2 kg
- Peso sin motor ~1.2 kg

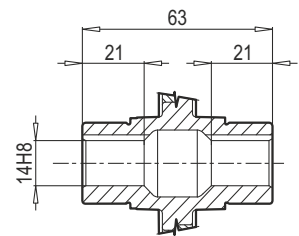
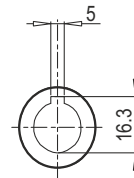
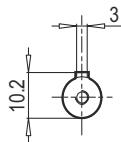
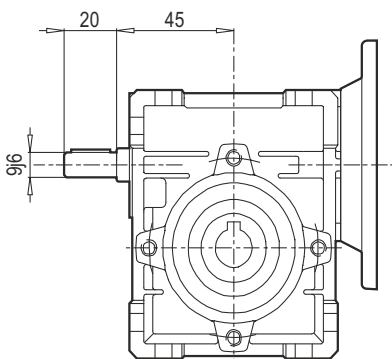

**VS**

Motor bağlantı flanşının boyutları için (Pm, Dm, bm, tm) sayfa 94'de verilen tabloya bakınız.  
 For the dimensions concerning the motor connection area (Pm, Dm, bm, tm) please refer to the table shown at page 94.  
 Zu den Abmessungen des Motoranschlußflansches (Pm, Dm, bm, tm) siehe tabella auf seite 94.  
 Per le dimensioni relative alla zona attacco motore (Pm, Dm, bm, tm) fare riferimento alla tabella di pag.94.  
 Pour les dimensions concernant la zone de montage du moteur (Pm, Dm, bm, tm) lire SVP le tableau à la page 94.  
 Para las magnitudes correspondientes a la zona del motor (Pm, Dm, bm, tm) consulte la tabla de la página 94.

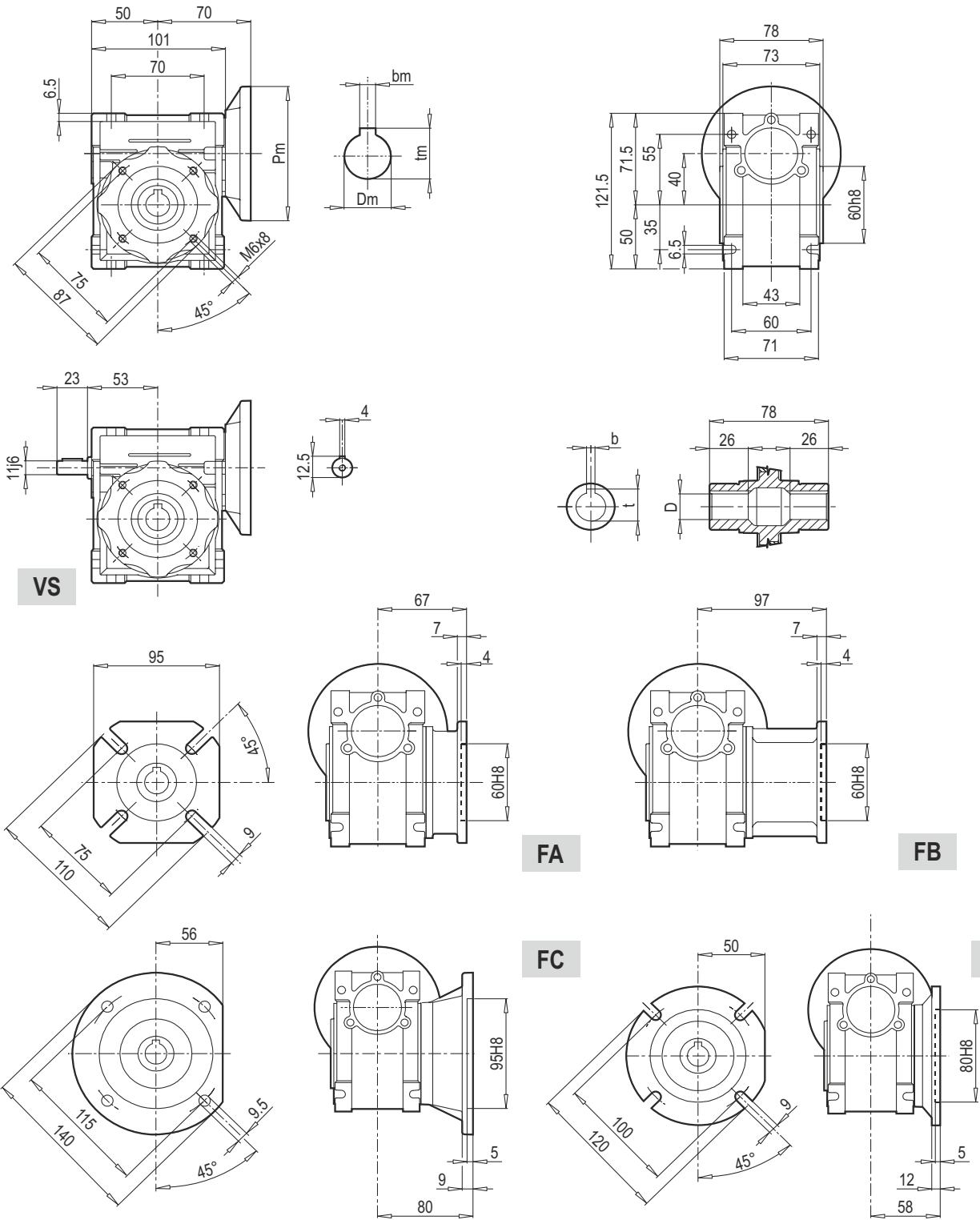

- |                                |                        |         |
|--------------------------------|------------------------|---------|
| (.) Sadece talebe bağlı olarak | - Motorsuz ağırlık     | ~2.3 kg |
| (..) Only on request           | - Weight without motor | ~2.3 kg |
| (..) Auf Wunsch                | - Gewicht ohne motor   | ~2.3 kg |
| (..) Solo su richiesta         | - Peso senza motore    | ~2.3 kg |
| (..) Seulement sur demande     | - Poids sans moteur    | ~2.3 kg |
| (..) Sólo bajo pedido          | - Peso sin motor       | ~2.3 kg |

Çıkış Şaftı / Output / Abtrieb / Uscita / Sortie / Salida		
D H7	b	t
18	6	20,8
(19)	(6)	(21,8)

Motor bağlantı flanşının boyutları için (Pm, Dm, bm, tm) sayfa 94'de verilen tabloya bakınız.  
 For the dimensions concerning the motor connection area (Pm, Dm, bm, tm) please refer to the table shown at page 94.  
 Zu den Abmessungen des Motoranschlußflansches (Pm, Dm, bm, tm) siehe tabella auf seite 94.  
 Per le dimensioni relative alla zona attacco motore (Pm, Dm, bm, tm) fare riferimento alla tabella di pag. 94.  
 Pour les dimensions concernant la zone de montage du moteur (Pm, Dm, bm, tm) lire SVP le tableau à la page 94.  
 Para las magnitudes correspondientes a la zona del motor (Pm, Dm, bm, tm) consulte la tabla de la página 94.

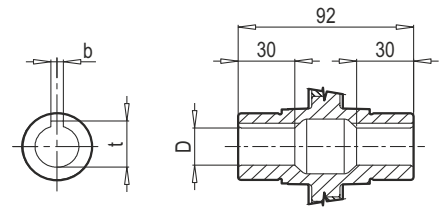
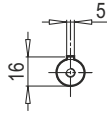
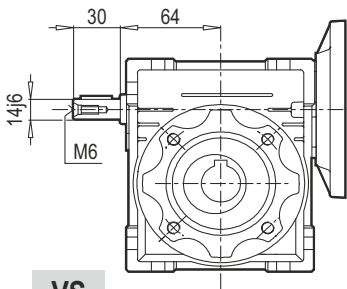
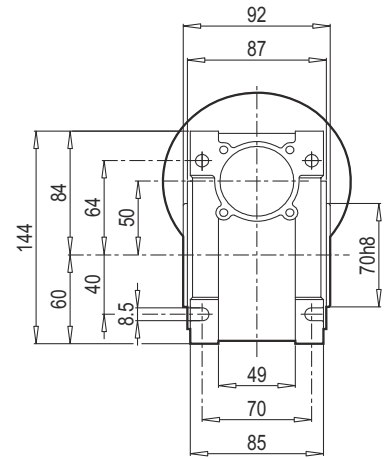
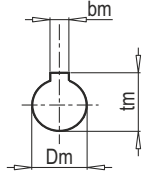
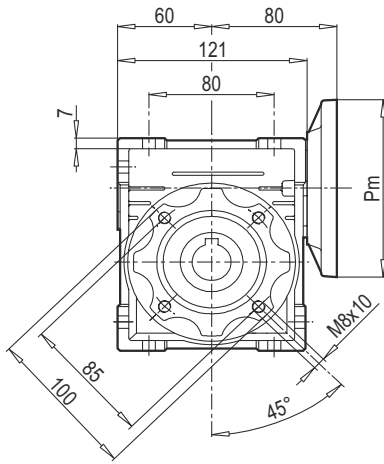

VS

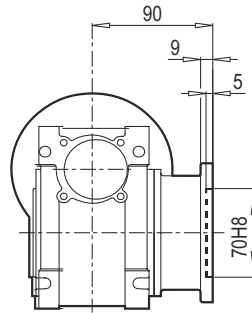
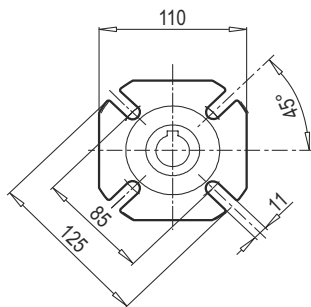

FA

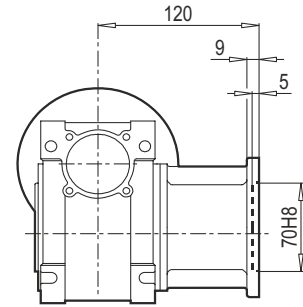

FB

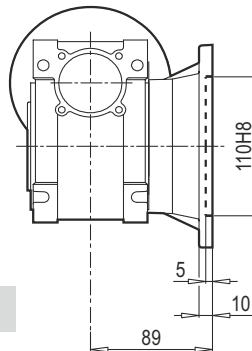
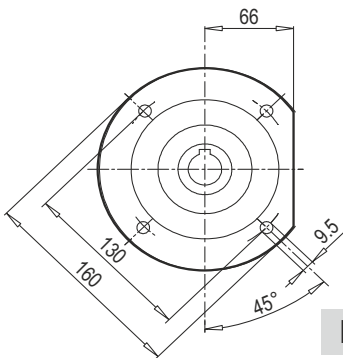

FC

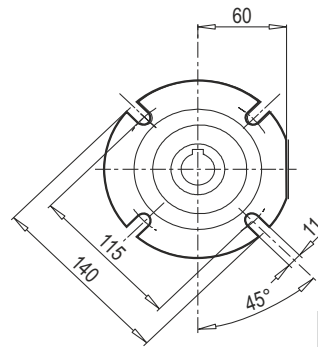

FD

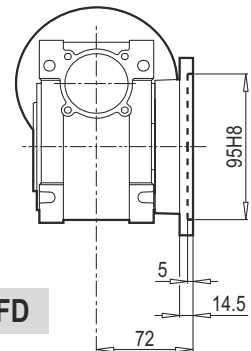

(..) Sadece talebe bağıli olarak  
(..) Only on request  
(..) Auf Wunsch  
(..) Solo su richiesta  
(..) Seulement sur demande  
(..) Sólo bajo pedido

- Motorsuz ağırlık ~3.5 kg  
- Weight without motor ~3.5 kg  
- Gewicht ohne motor ~3.5 kg  
- Peso senza motore ~3.5 kg  
- Poids sans moteur ~3.5 kg  
- Peso sin motor ~3.5 kg

Çıkış Şaftı / Output / Abtrieb / Uscita / Sortie / Salida		
D H7	b	t
25	8	28,3
(24)	(8)	(27,3)

Motor bağlantı flanşının boyutları için (Pm, Dm, bm, tm) sayfa 94'de verilen tabloya bakınız.  
For the dimensions concerning the motor connection area (Pm, Dm, bm, tm) please refer to the table shown at page 94.  
Zu den Abmessungen des Motorschlusflansches (Pm, Dm, bm, tm) siehe tabella auf seite 94.  
Per le dimensioni relative alla zona attacco motore (Pm, Dm, bm, tm) fare riferimento alla tabella di pag.94.  
Pour les dimensions concernant la zone de montage du moteur (Pm, Dm, bm, tm) lire SVP le tableau à la page 94.  
Para las magnitudes correspondientes a la zona del motor (Pm, Dm, bm, tm) consulte la tabla de la página 94.

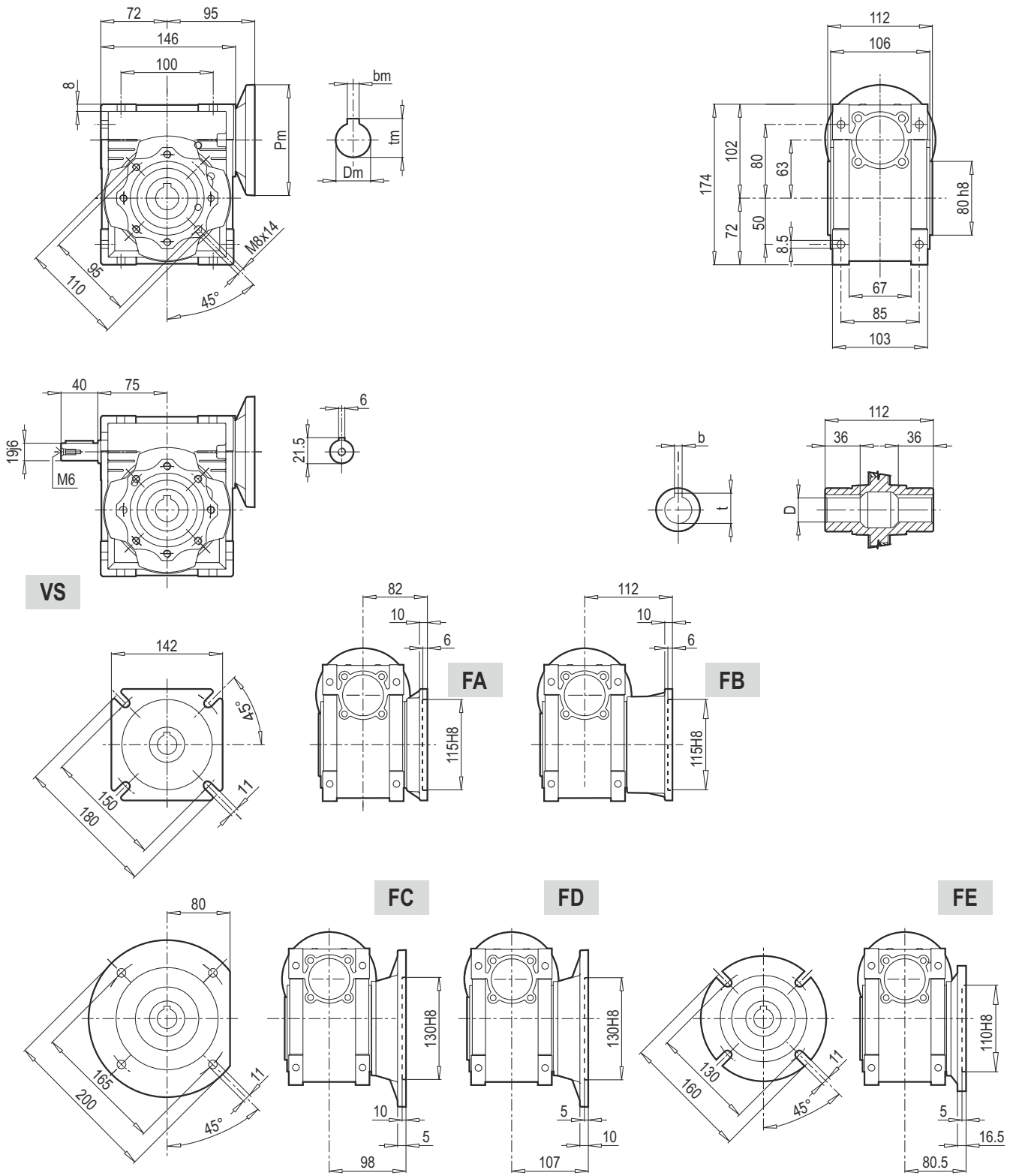

Çıkış Şaftı / Output / Abtrieb/ Uscita / Sortie / Salida		
D H7	b	t
25	8	28,3
(28)	(8)	(31,3)

(..) Sadece talebe bağlı olarak  
 (..) Only on request  
 (..) Auf Wunsch  
 (..) Solo su richiesta  
 (..) Seulement sur demande  
 (..) Sólo bajo pedido

- Motorsuz ağırlık ~6.2 kg  
 - Weight without motor ~6.2 kg  
 - Gewicht ohne motor ~6.2 kg  
 - Peso senza motore ~6.2 kg  
 - Poids sans moteur ~6.2 kg  
 - Peso sin motor ~6.2 kg

Motor bağlantı flanşının boyutları için (Pm, Dm, bm, tm) sayfa 94'de verilen tabloya bakınız.  
 For the dimensions concerning the motor connection area (Pm, Dm, bm, tm) please refer to the table shown at page 94.  
 Zu den Abmessungen des Motoranschlußflansches (Pm, Dm, bm, tm) siehe tabella auf seite 94.  
 Per le dimensioni relative alla zona attacco motore (Pm, Dm, bm, tm) fare riferimento alla tabella di pag. 94.  
 Pour les dimensions concernant la zone de montage du moteur (Pm, Dm, bm, tm) lire SVP le tableau à la page 94.  
 Para las magnitudes correspondientes a la zona del motor (Pm, Dm, bm, tm) consulte la tabla de la página 94.

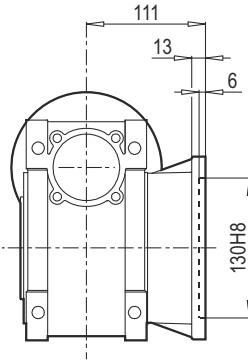
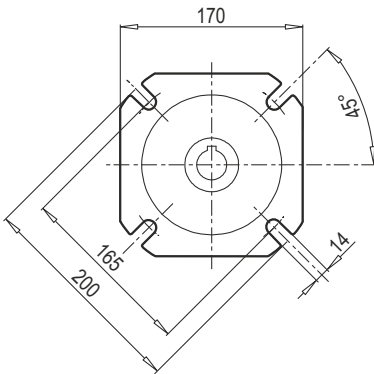
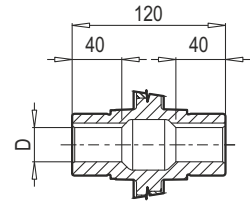
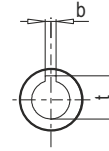
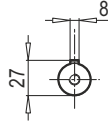
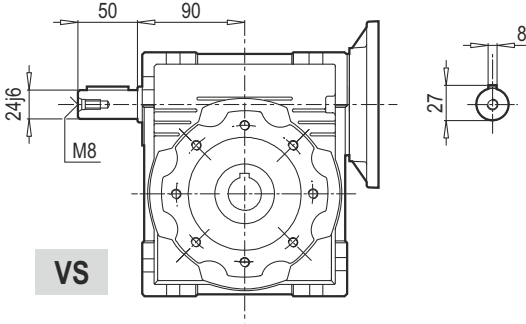
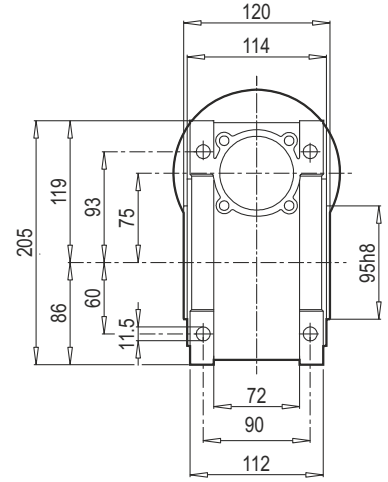
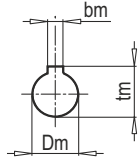
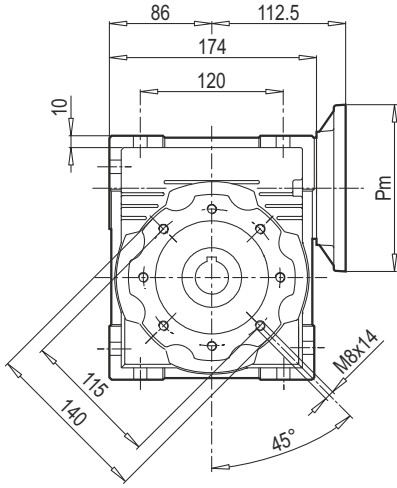

FA

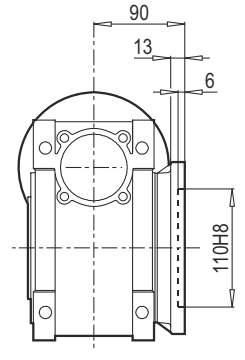
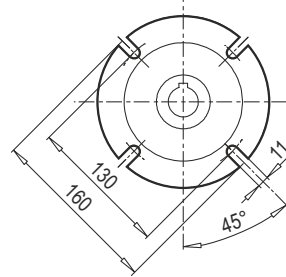

FB

Çıkış Şaftı / Output / Abtrieb / Uscita / Sortie / Salida		
D H7	b	t
28	8	31,3
(35)	(10)	(38,3)

(..) Sadece talebe bağlı olarak  
(..) Only on request  
(..) Auf Wunsch  
(..) Solo su richiesta  
(..) Seulement sur demande  
(..) Sólo bajo pedido

- Motorsuz ağırlık ~9 kg  
- Weight without motor ~9 kg  
- Gewicht ohne motor ~9 kg  
- Peso senza motore ~9 kg  
- Poids sans moteur ~9 kg  
- Peso sin motor ~9 kg

Motor bağlantı flanşının boyutları için (Pm, Dm, bm, tm) sayfa 94'de verilen tabloya bakınız.  
For the dimensions concerning the motor connection area (Pm, Dm, bm, tm) please refer to the table shown at page 94.  
Zu den Abmessungen des Motoranschlußflansches (Pm, Dm, bm, tm) siehe tabella auf seite 94.  
Per le dimensioni relative alla zona attacco motore (Pm, Dm, bm, tm) fare riferimento alla tabella di pag. 94.  
Pour les dimensions concernant la zone de montage du moteur (Pm, Dm, bm, tm) lire SVP le tableau à la page 94.  
Para las magnitudes correspondientes a la zona del motor (Pm, Dm, bm, tm) consulte la tabla de la página 94.

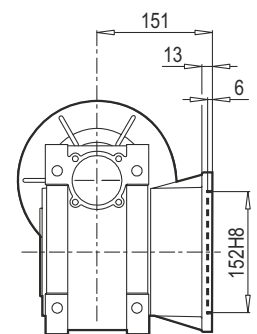
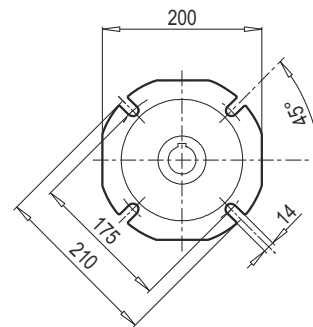
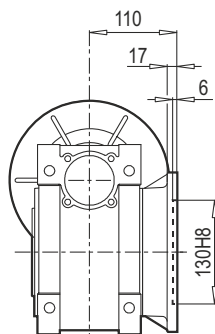
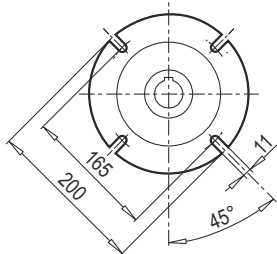
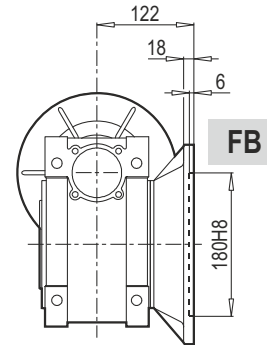
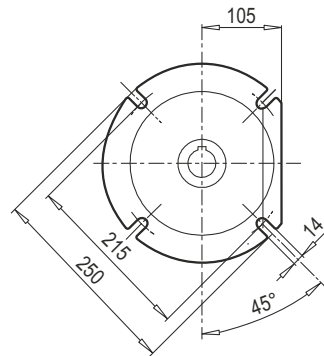
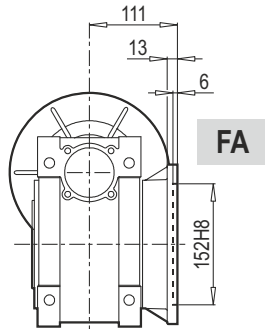
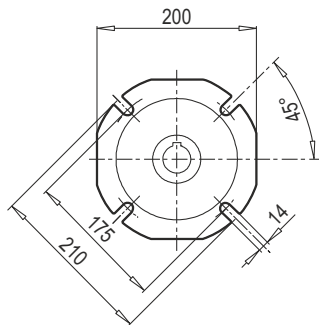
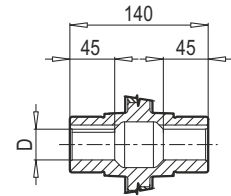
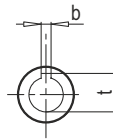
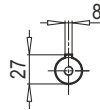
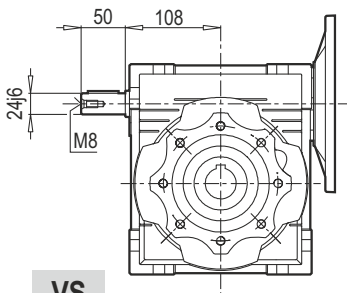
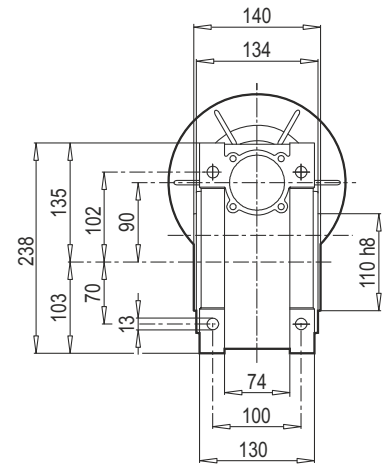
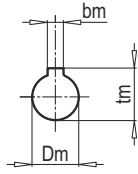
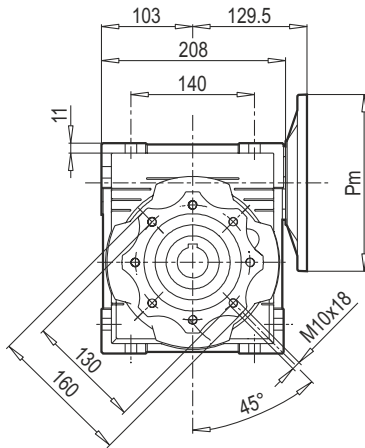

Çıkış Şaftı / Output / Abtrieb / Uscita / Sortie / Salida		
D H7	b	t
35	10	38,3
(38)	(10)	(41,3)

(..) Sadece talebe bağlı olarak  
 (..) Only on request  
 (..) Auf Wunsch  
 (..) Solo su richiesta  
 (..) Seulement sur demande  
 (..) Sólo bajo pedido

- Motorsuz ağırlık ~13 kg  
 - Weight without motor ~13 kg  
 - Gewicht ohne motor ~13 kg  
 - Peso senza motore ~13 kg  
 - Poids sans moteur ~13 kg  
 - Peso sin motor ~13 kg

Motor bağlantı flanşının boyutları için (Pm, Dm, bm, tm) sayfa 94'de verilen tabloya bakınız.  
 For the dimensions concerning the motor connection area (Pm, Dm, bm, tm) please refer to the table shown at page 94.  
 Zu den Abmessungen des Motoranschlusßflansches (Pm, Dm, bm, tm) siehe tabella auf seite 94.  
 Per le dimensioni relative alla zona attacco motore (Pm, Dm, bm, tm) fare riferimento alla tabella di pag. 94.  
 Pour les dimensions concernant la zone de montage du moteur (Pm, Dm, bm, tm) lire SVP le tableau à la page 94.  
 Para las magnitudes correspondientes a la zona del motor (Pm, Dm, bm, tm) consulte la tabla de la página 94.

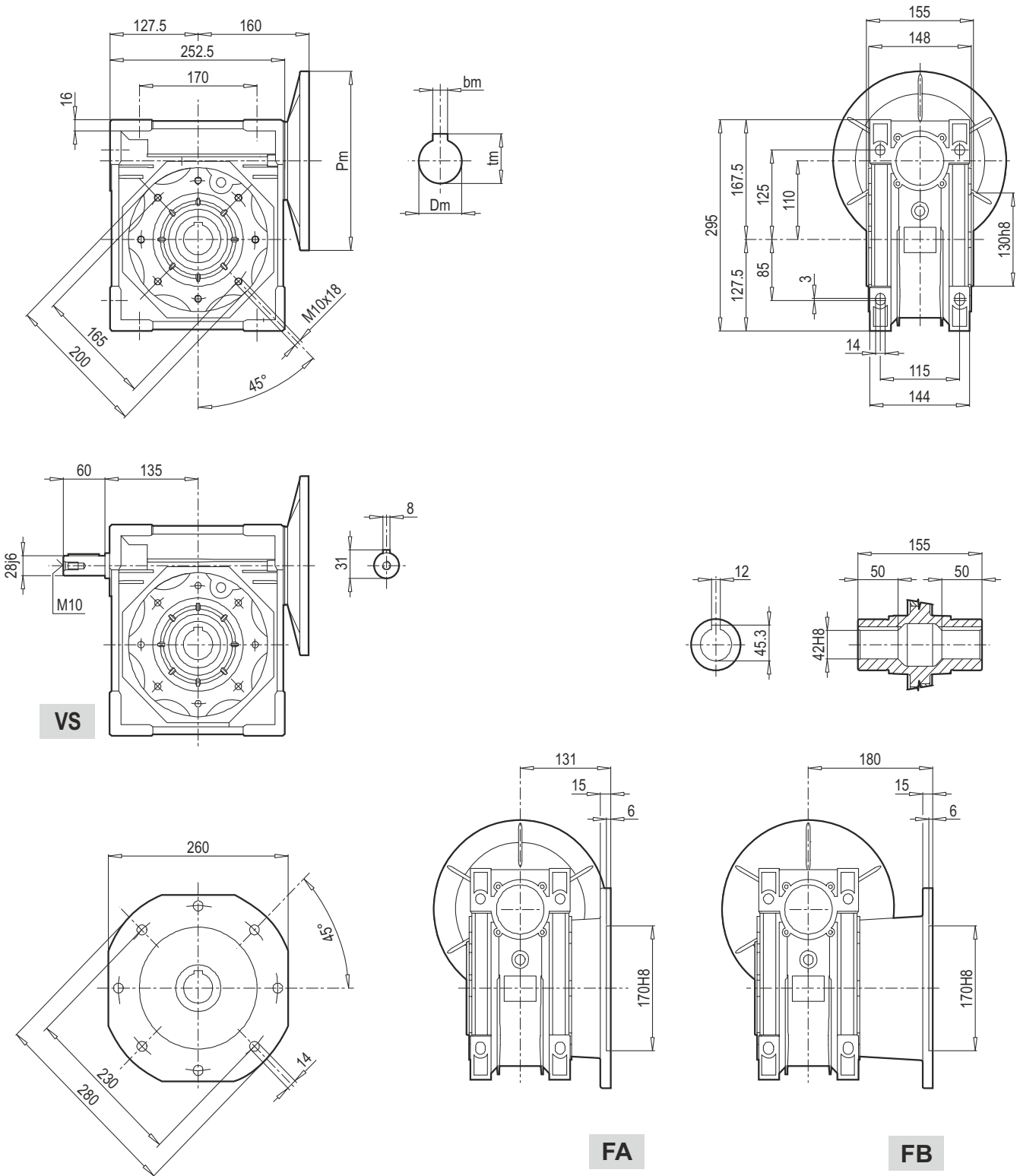

- Motorsuz ağırlık ~21 kg
- Weight without motor ~21 kg
- Gewicht ohne motor ~21 kg
- Peso senza motore ~21 kg
- Poids sans moteur ~21 kg
- Peso sin motor ~21 kg

Motor bağlantı flanşının boyutları için (Pm, Dm, bm, tm) sayfa 94'de verilen tabloya bakınız.  
 For the dimensions concerning the motor connection area (Pm, Dm, bm, tm) please refer to the table shown at page 94.  
 Zu den Abmessungen des Motoranschlußflansches (Pm, Dm, bm, tm) siehe tabella auf seite 94.  
 Per le dimensioni relative alla zona attacco motore (Pm, Dm, bm, tm) fare riferimento alla tabella di pag. 94.  
 Pour les dimensions concernant la zone de montage du moteur (Pm, Dm, bm, tm) lire SVP le tableau à la page 94.  
 Para las magnitudes correspondientes a la zona del motor (Pm, Dm, bm, tm) consulte la tabla de la página 94.

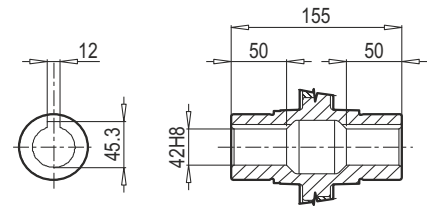
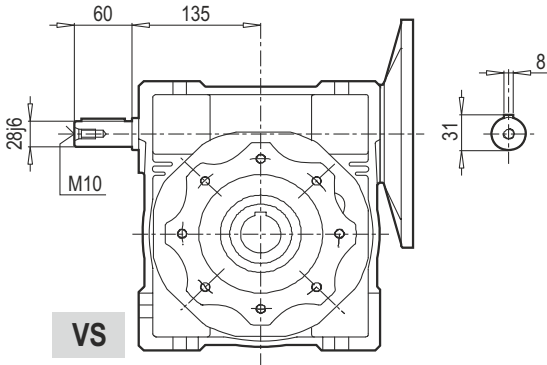
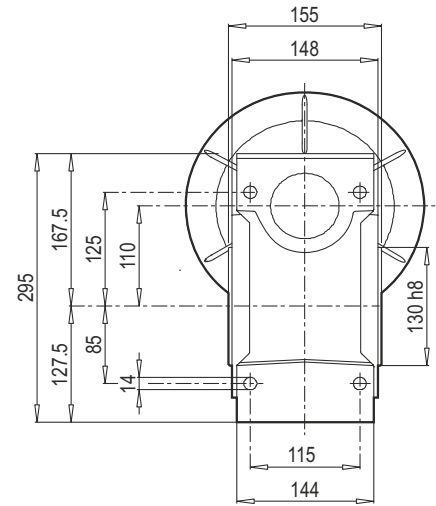
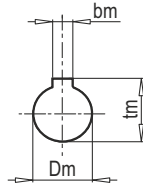
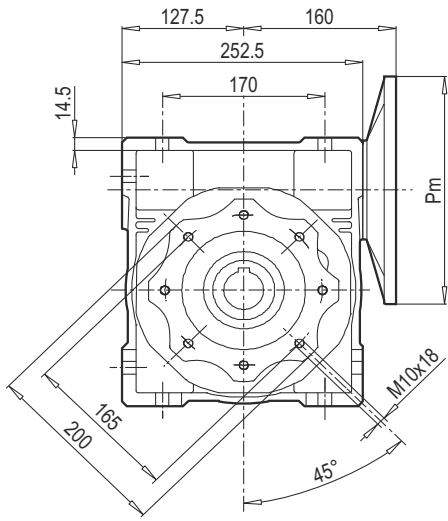

**VS**

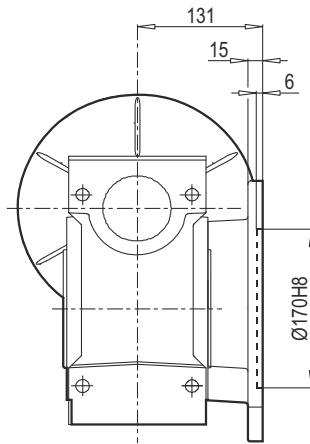
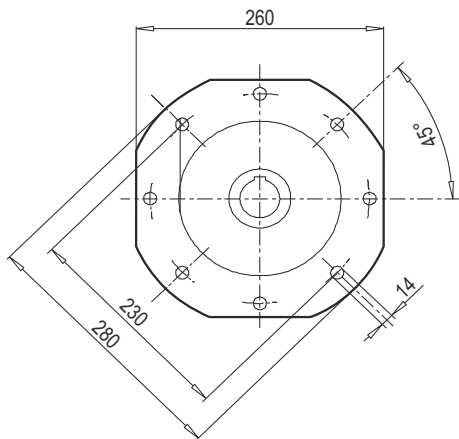

**FA**

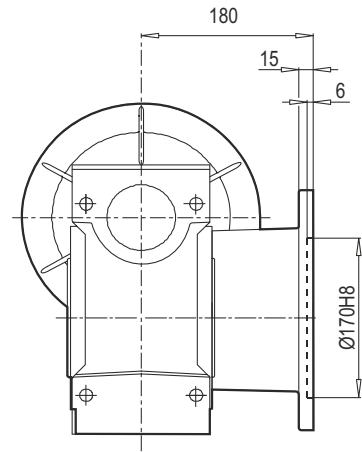

**FB**

- Motorsuz ağırlık ~35 kg
- Weight without motor ~35 kg
- Gewicht ohne motor ~35 kg
- Peso senza motore ~35 kg
- Poids sans moteur ~35 kg
- Peso sin motor ~35 kg

Motor bağlantı flanşının boyutları için (Pm, Dm, bm, tm) sayfa 94'de verilen tabloya bakınız.  
 For the dimensions concerning the motor connection area (Pm, Dm, bm, tm) please refer to the table shown at page 94.  
 Zu den Abmessungen des Motoranschlußflansches (Pm, Dm, bm, tm) siehe tabella auf seite 94.  
 Per le dimensioni relative alla zona attacco motore (Pm, Dm, bm, tm) fare riferimento alla tabella di pag. 94.  
 Pour les dimensions concernant la zone de montage du moteur (Pm, Dm, bm, tm) lire SVP le tableau à la page 94.  
 Para las magnitudes correspondientes a la zona del motor (Pm, Dm, bm, tm) consulte la tabla de la página 94.



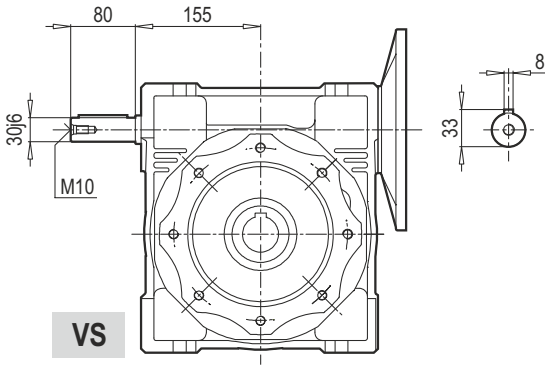
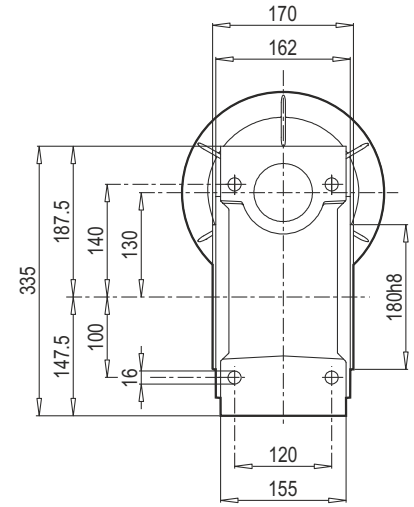
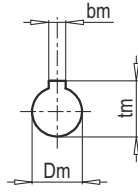
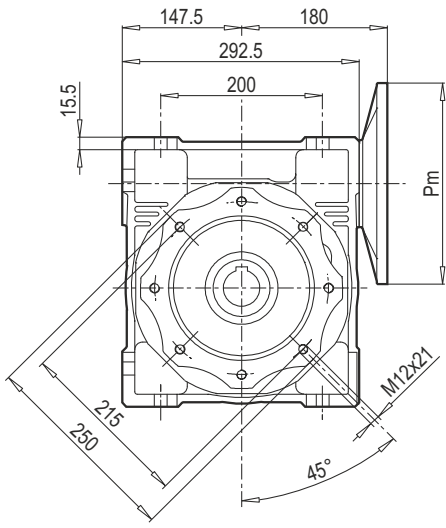

**VS**

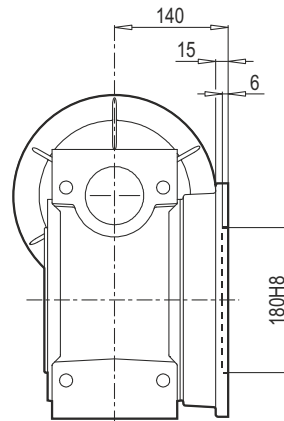
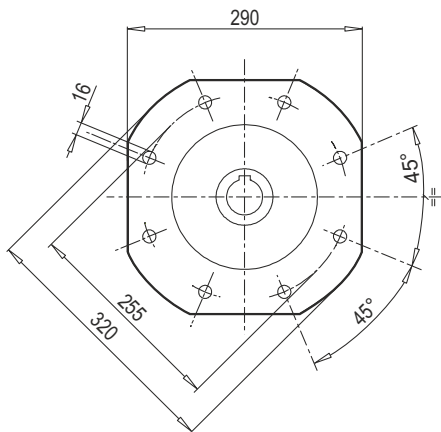
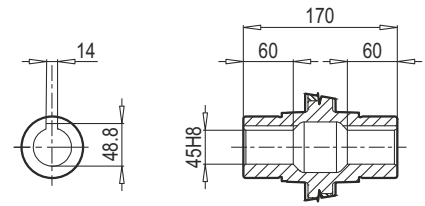

**FA**

- Motorsuz ağırlık ~48 kg
- Weight without motor ~48 kg
- Gewicht ohne motor ~48 kg
- Peso senza motore ~48 kg
- Poids sans moteur ~48 kg
- Peso sin motor ~48 kg

Motor bağlantı flanşının boyutları için (Pm, Dm, bm, tm) sayfa 94'de verilen tabloya bakınız.  
For the dimensions concerning the motor connection area (Pm, Dm, bm, tm) please refer to the table shown at page 94.  
Zu den Abmessungen des Motoranschlußflansches (Pm, Dm, bm, tm) siehe tabella auf seite 94.  
Per le dimensioni relative alla zona attacco motore (Pm, Dm, bm, tm) fare riferimento alla tabella di pag. 94.  
Pour les dimensions concernant la zone de montage du moteur (Pm, Dm, bm, tm) lire SVP le tableau à la page 94.  
Para las magnitudes correspondientes a la zona del motor (Pm, Dm, bm, tm) consulte la tabla de la página 94.

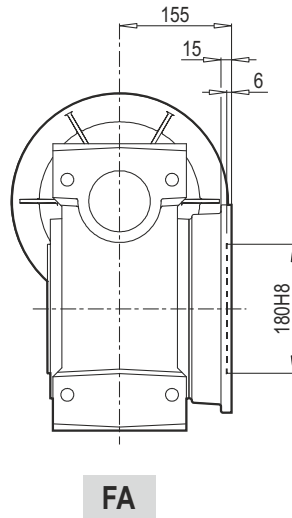
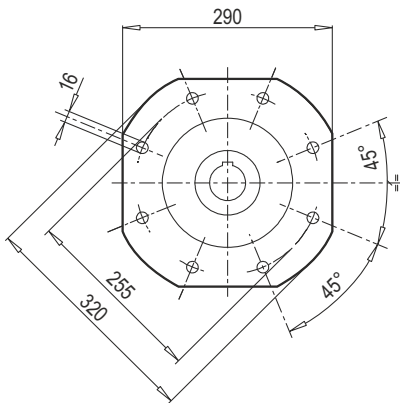
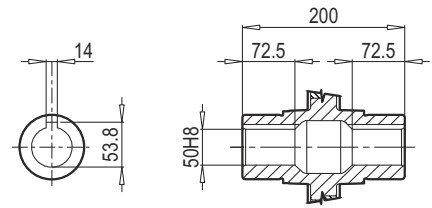
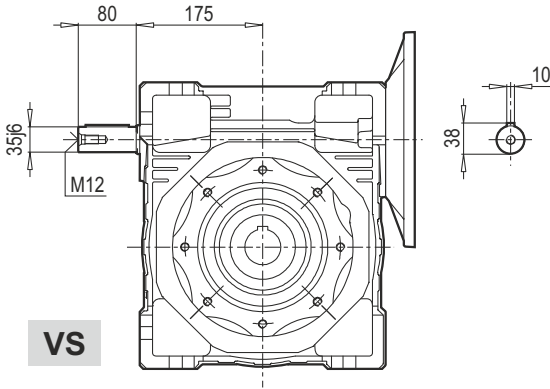
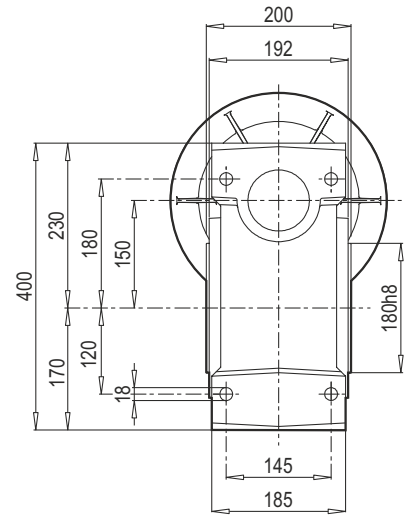
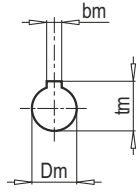
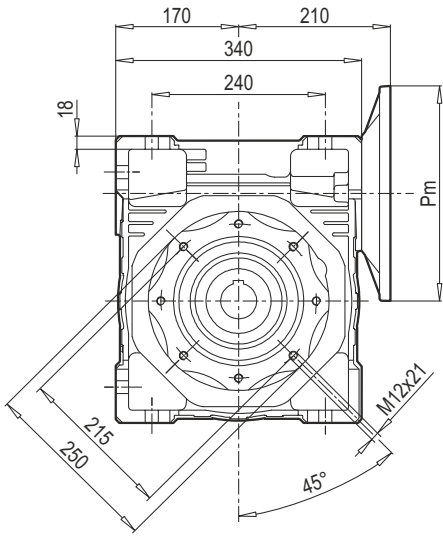

- Motorsuz ağırlık ~84 kg
- Weight without motor ~84 kg
- Gewicht ohne motor ~84 kg
- Peso senza motore ~84 kg
- Poids sans moteur ~84 kg
- Peso sin motor ~84 kg

Motor bağlantı flanşının boyutları için (Pm, Dm, bm, tm) sayfa 94'de verilen tabloya bakınız.  
 For the dimensions concerning the motor connection area (Pm, Dm, bm, tm) please refer to the table shown at page 94.  
 Zu den Abmessungen des Motoranschlußflansches (Pm, Dm, bm, tm) siehe tabella auf seite 94.  
 Per le dimensioni relative alla zona attacco motore (Pm, Dm, bm, tm) fare riferimento alla tabella di pag.94.  
 Pour les dimensions concernant la zone de montage du moteur (Pm, Dm, bm, tm) lire SVP le tableau à la page 94.  
 Para las magnitudes correspondientes a la zona del motor (Pm, Dm, bm, tm) consulte la tabla de la página 94.

- Çıkış flanşının ölçüleri için PMRV ölçüleri ile ilgili çizimlere bakınız.
- For the dimensions of the output flanges, please consider the drawing of relevant PMRV size.
- Die Maße der Abtriebsflansche, sind der Maßzeichnung des PMRV der entsprechenden Größe zu entnehmen.
- Per le dimensioni relative alla flangia di uscita, fare riferimento al dimensionale PMRV della grandezza relativa.
- Pour les dimensions relatives aux brides de sortie, nous vous prions de vous référer au dessin PMRV dans la taille désirée.
- Paras las cotas correspondientes a la brida de salida, hacer referencia a las dimensiones PMRV del tamaño correspondiente.

- Opsiyonel olarak kullanılan delik millilerin ölçüleri için PMRV ölçüleri ile ilgili çizimlere bakınız.
- For the dimensions of the hollow shafts in option, please consider the drawing of relevant PMRV size.
- Die Maße der auf Anfrage lieferbaren Hohlwellen sind der Maßzeichnung des PMRV der entsprechenden Größe zu entnehmen.
- Per le dimensioni relative agli alberi cavi in versione opzionale, fare riferimento al dimensionale PMRV della grandezza relativa.
- Pour les dimensions relatives aux arbres creux en version optionnelle, nous vous prions de vous référer au dessin PMRV dans la taille désirée.
- Paras las cotas correspondientes a los ejes huecos en la version opcional, hacer referencia a las dimensiones PMRV del tamaño correspondiente.

- Çift çıkışlı şaft ölçüleri için PMRV ölçüleri ile ilgili çizimlere bakınız.
- For the dimensions of the double extention worm shafts, please consider the drawing of relevant PMRV size.
- Die Maße des doppelten Schneckenwellenendes sind der Maßzeichnung des PMRV der entsprechenden Größe zu entnehmen.
- Per le dimensioni relative alla vite bisporgente, fare riferimento al dimensionale PMRV della grandezza relativa.
- Pour les dimensions relatives aux vis sans fin avec double sorties, nous vous prions de vous référer au dessin PMRV dans la taille désirée.
- Para las cotas correspondientes al tornillo sinfin prolongado, hacer referencia a las dimensiones PMRV del tamaño correspondiente.

### PPC 063 - PMRV 040

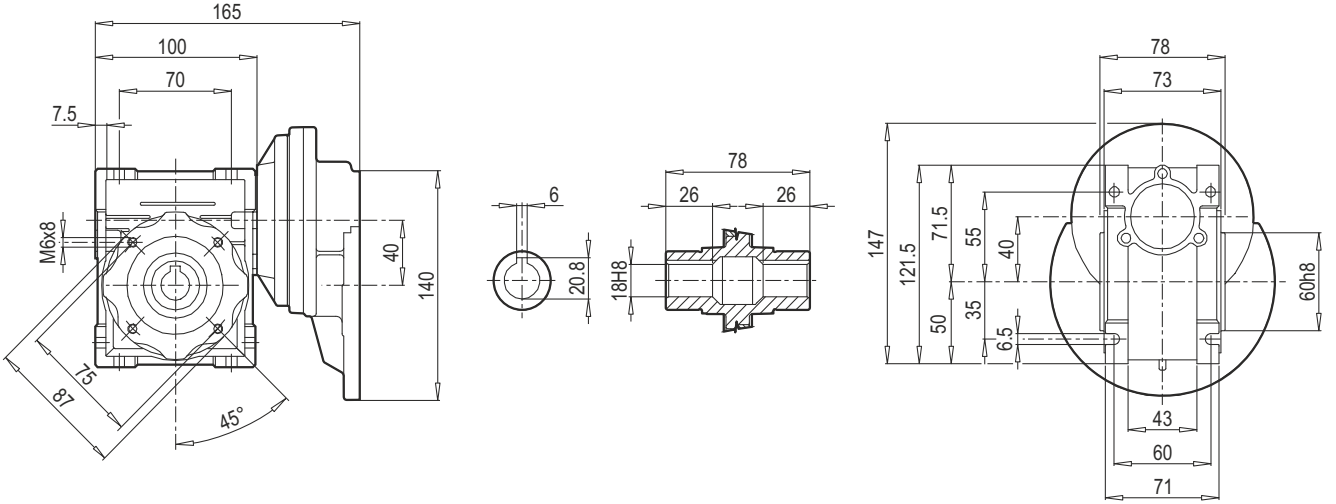

### PPC 063 - PMRV 050

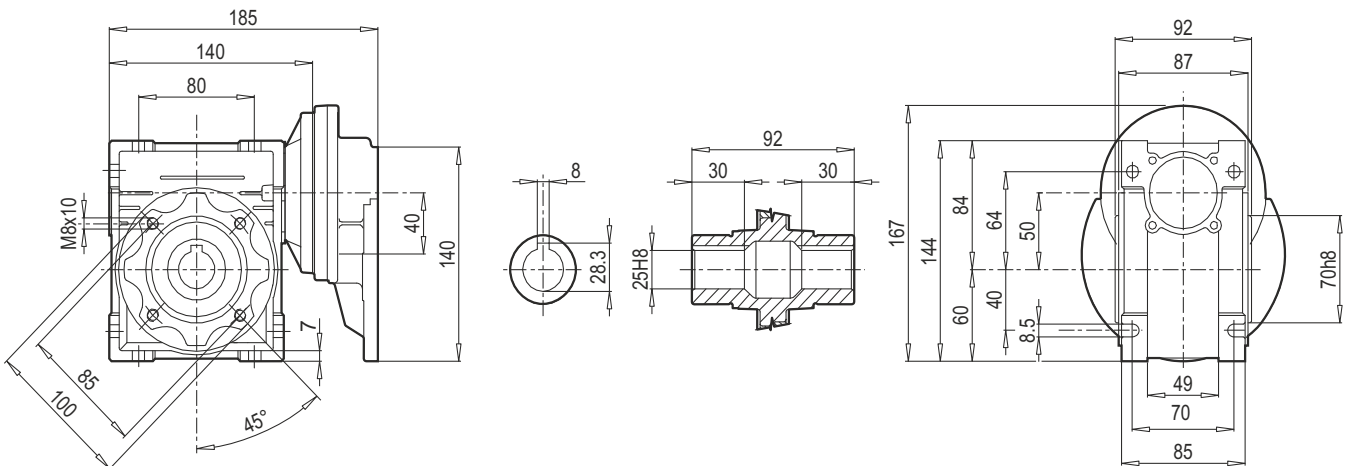

**PPC 063 - PMRV 063**

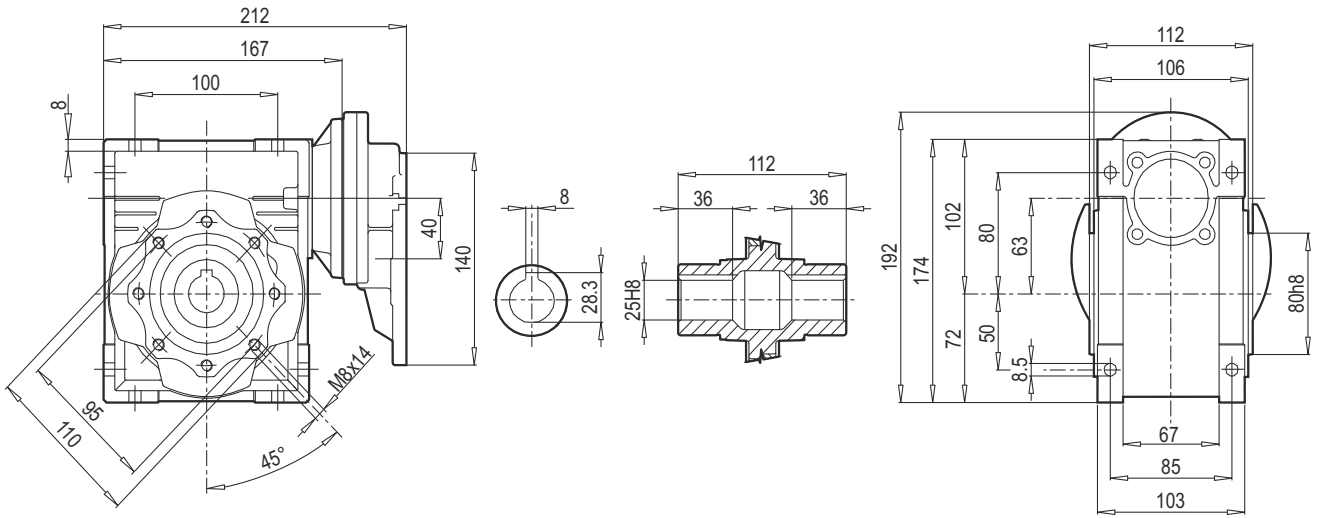

**PPC 071 - PMRV 050**

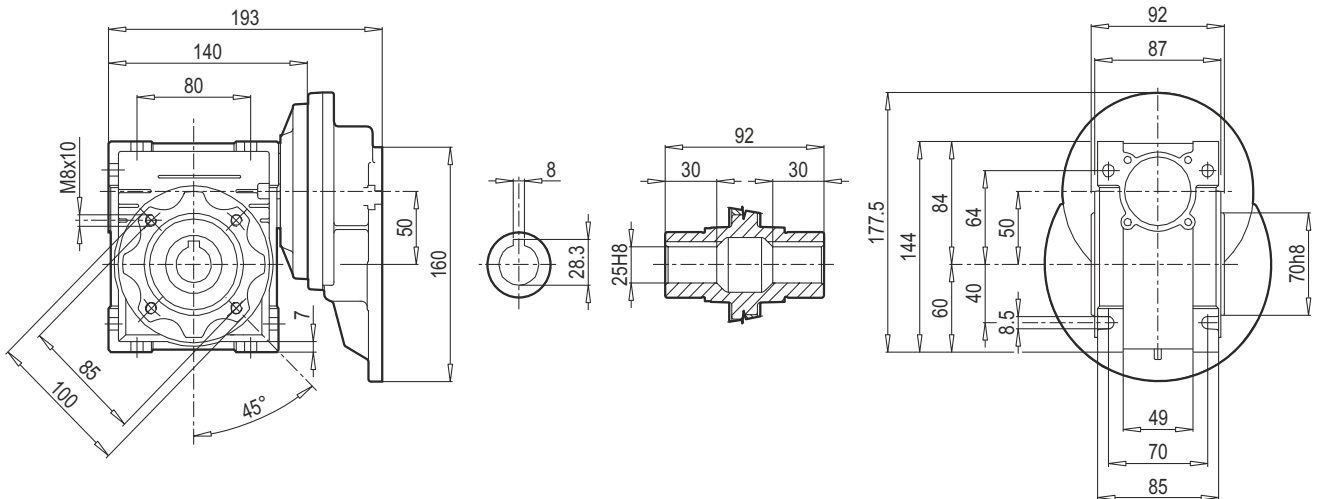

**PPC 071 - PMRV 063**

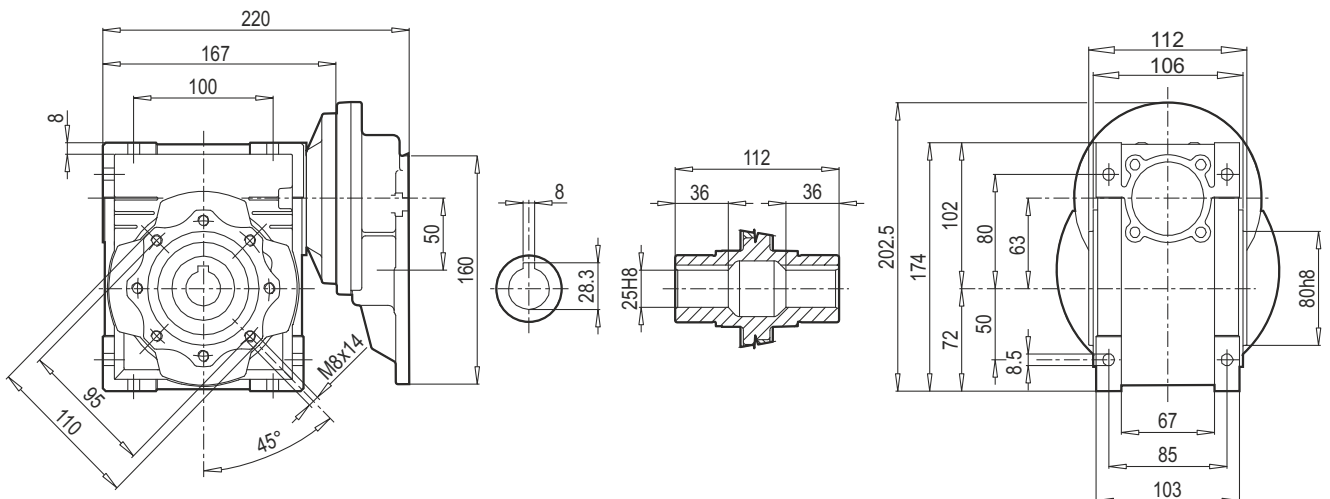

**PPC 071 - PMRV 075**

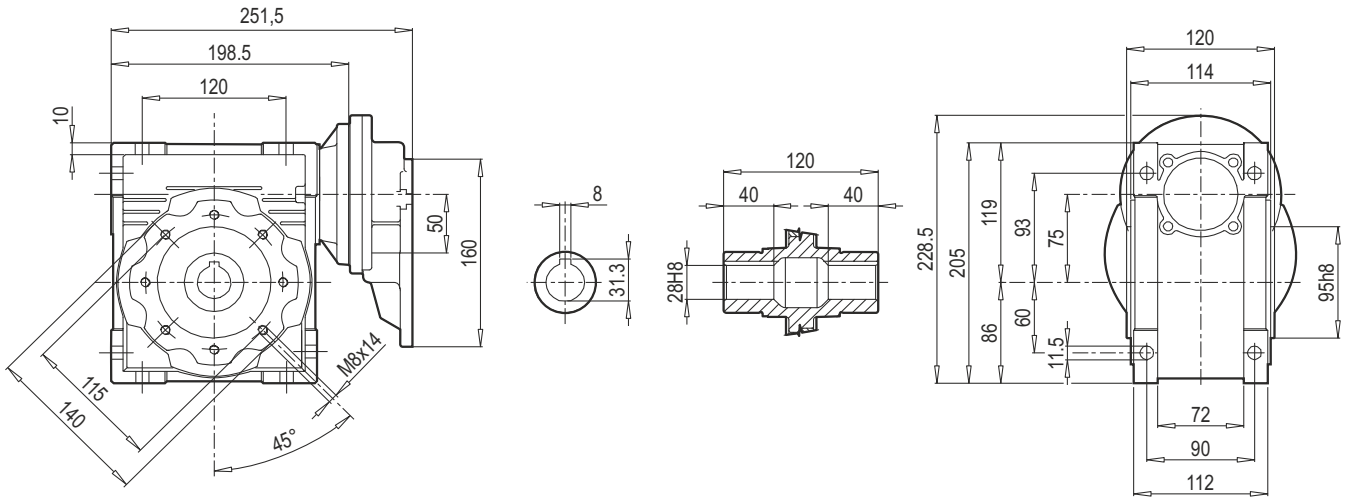

**PPC 071 - PMRV 090**

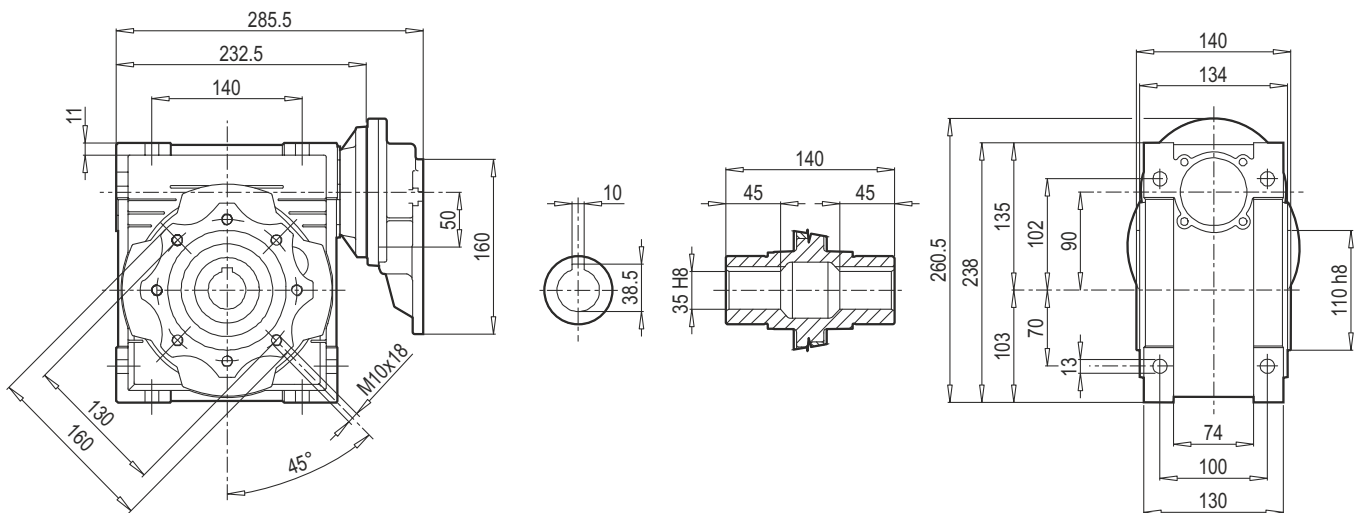

**PPC 080 - PMRV 075**

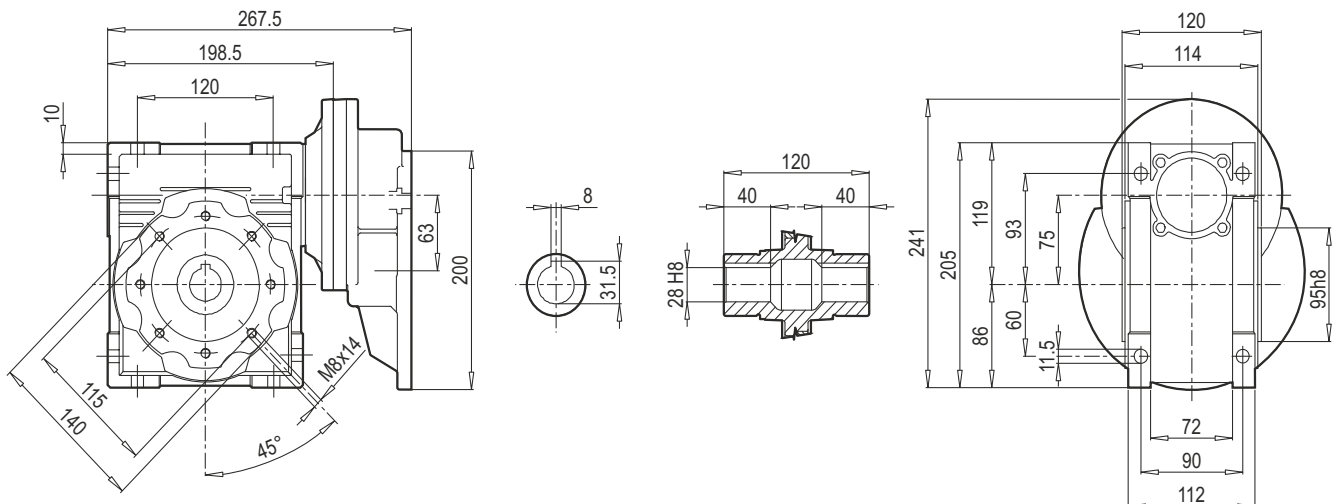

**PPC 080 - PMRV 090**

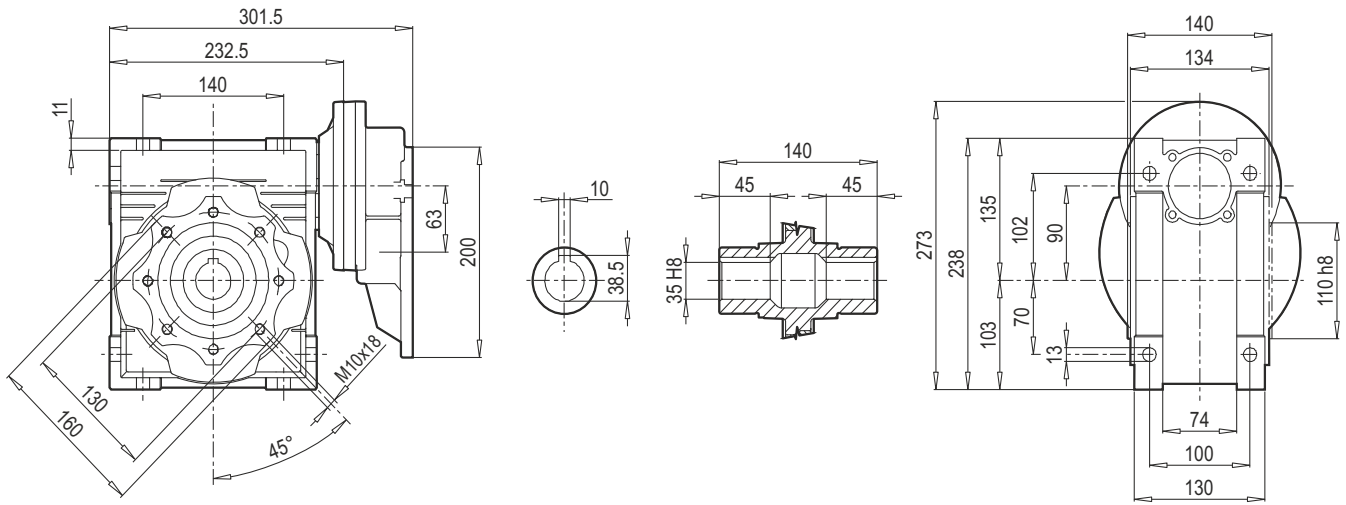

**PPC 080 - PMRV 105**  
**PPC 090 - PMRV 105**

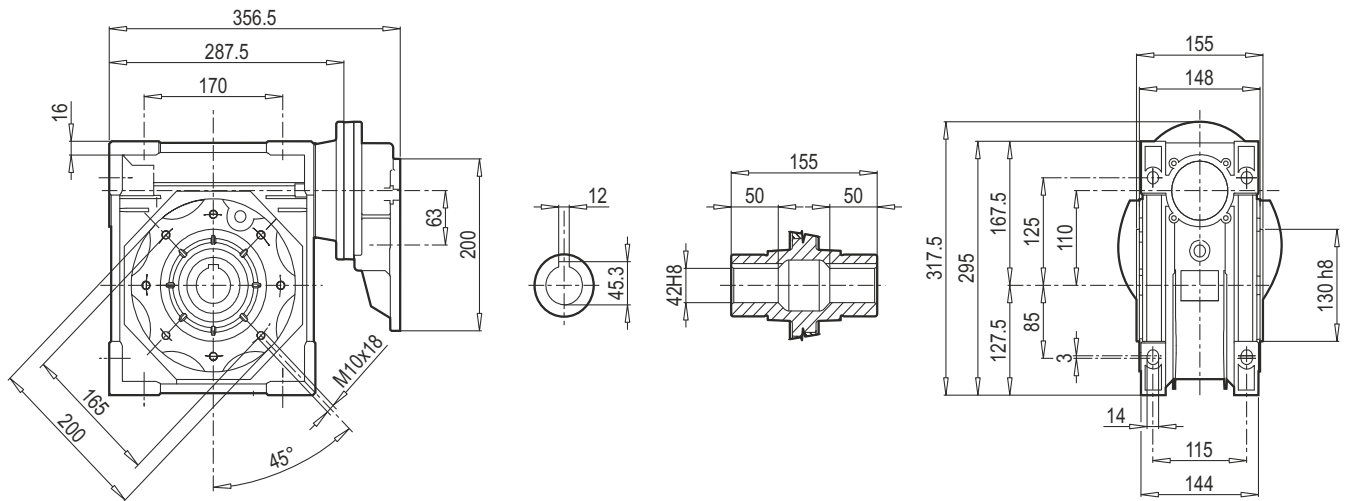

**PPC 080 - PMRV 110**  
**PPC 090 - PMRV 110**

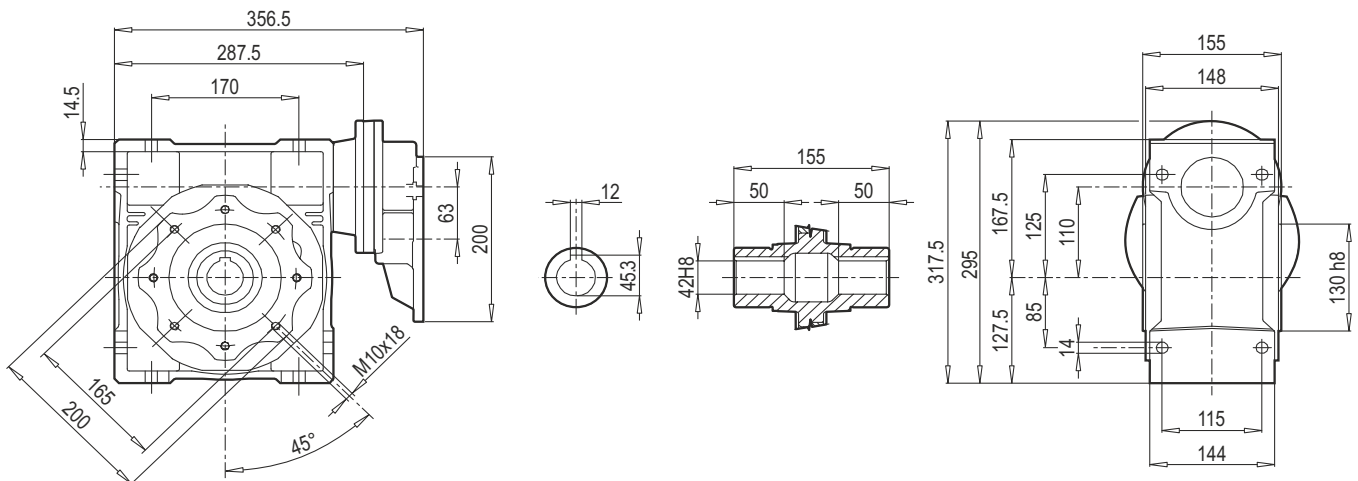

**PPC 080 - PMRV 130**  
**PPC 090 - PMRV 130**

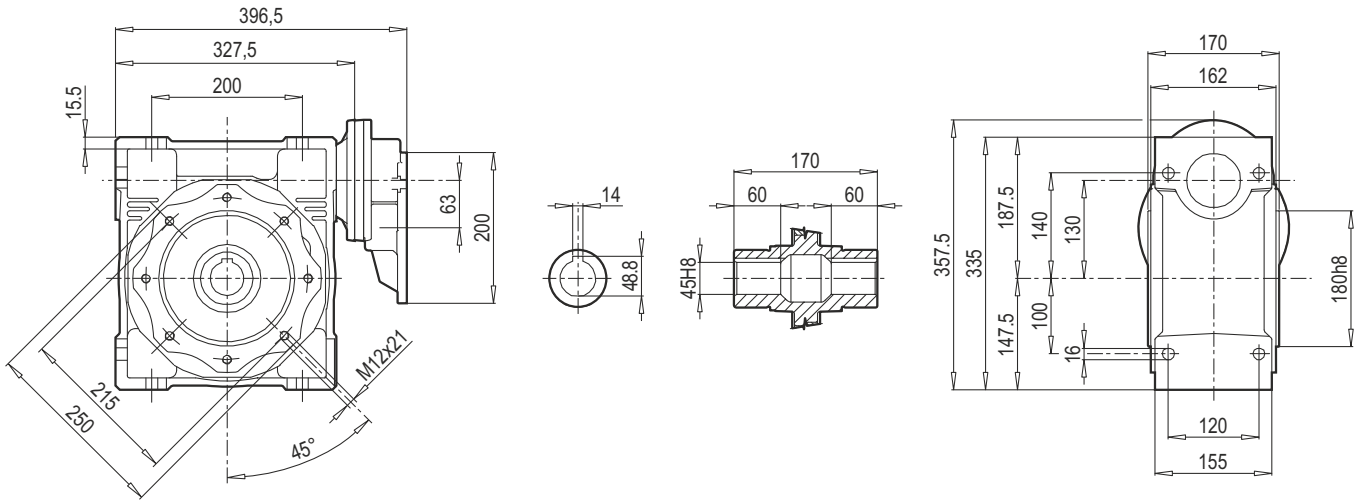

- Çıkış flanşlarının ölçüleri için PMRV ölçüleri ile ilgili çizimlere bakınız.
  - For the dimensions of the output flanges, please consider the drawing of relevant PMRV size.
  - Die Maße der Abtriebsflansche F-FL sind der Maßzeichnung des PMRV der entsprechenden Größe zu entnehmen.
  - Per le dimensioni relative alla flangia di uscita, fare riferimento al dimensionale PMRV della grandezza relativa.
  - Pour les dimensions relatives aux brides de sortie, nous vous prions de vous référer au dessin PMRV dans la taille désirée.
  - Para las cotas correspondientes a la brida de salida, hacer referencia a las dimensiones PMRV del tamaño correspondiente.
- 
- Opsiyonel olarak kullanılan delik millilerin ölçüleri için PMRV ölçüleri ile ilgili çizimlere bakınız.
  - For the dimensions of the hollow shafts in option, please consider the drawing of relevant PMRV size.
  - Die Maße der auf Anfrage lieferbaren Hohlwellen sind der Maßzeichnung des PMRV der entsprechenden Größe zu entnehmen.
  - Per le dimensioni relative agli alberi cavi in versione opzionale, fare riferimento al dimensionale PMRV della grandezza relativa.
  - Pour les dimensions relatives aux arbres creux en version optionnelle, nous vous prions de vous référer au dessin PMRV dans la taille désirée.
  - Para las cotas correspondientes a los ejes huecos en la version opcional, hacer referencia a las dimensiones PMRV del tamaño correspondiente.
- 
- Çift çıkışlı şaft ölçüleri için PMRV ölçüleri ile ilgili çizimlere bakınız.
  - For the dimensions of the double extention worm shafts, please consider the drawing of relevant PMRV size.
  - Die Maße des doppelten Schneckenwellenendes sind der Maßzeichnung des PMRV der entsprechenden Größe zu entnehmen.
  - Per le dimensioni relative alla vite bisporgente, fare riferimento al dimensionale PMRV della grandezza relativa.
  - Pour les dimensions relatives aux vis sans fin avec double sorties, nous vous prions de vous référer au dessin PMRV dans la taille désirée.
  - Paras las cotas correspondientes al tornillo sinfin prolongado, hacer referencia a las dimensiones PMRV del tamaño correspondiente.

### PMRV 030-040

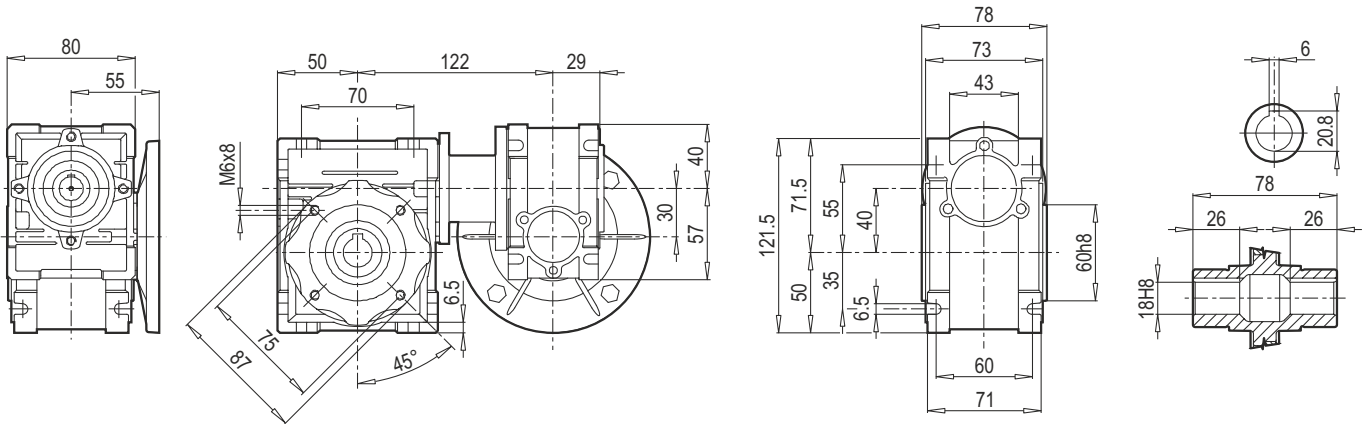

### PMRV 030-050

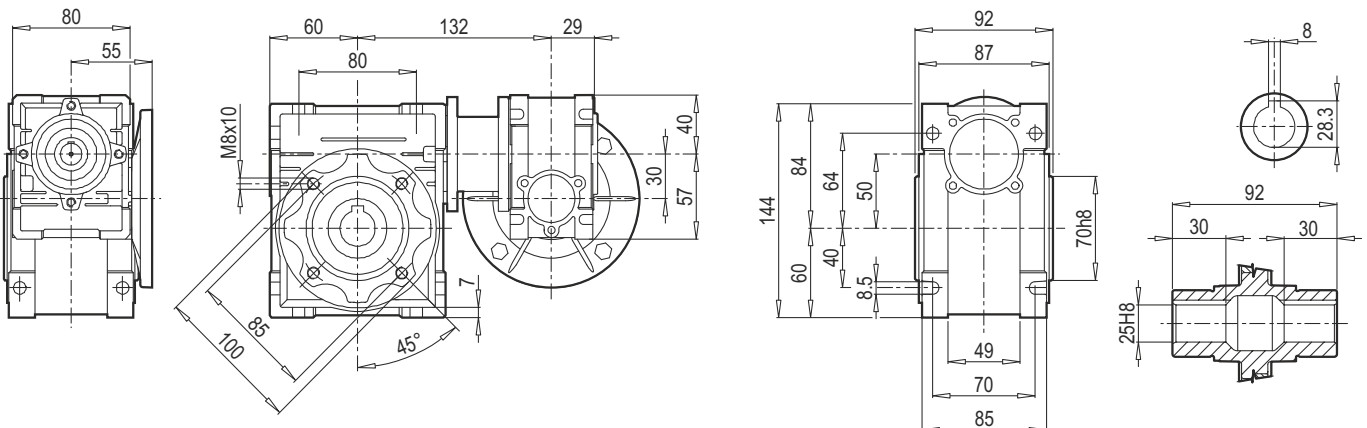



**PMRV 030-063**

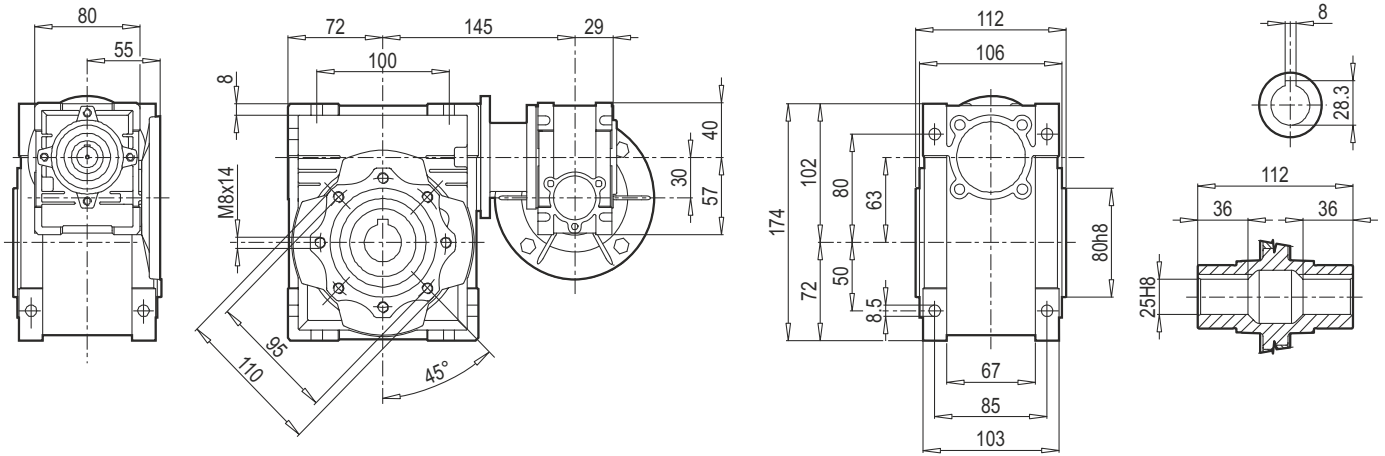

**PMRV 040-075**

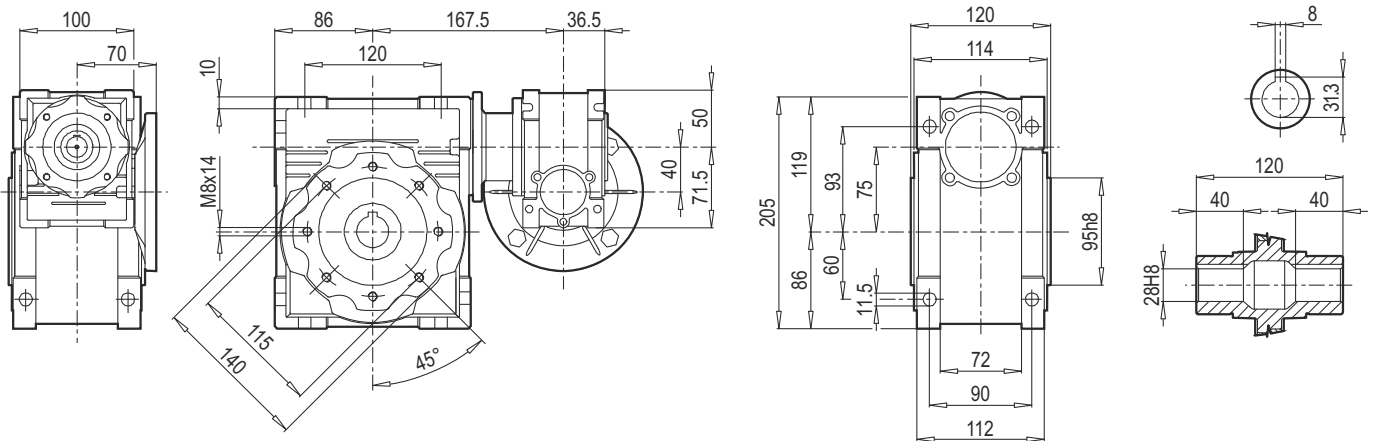

**PMRV 040-090**

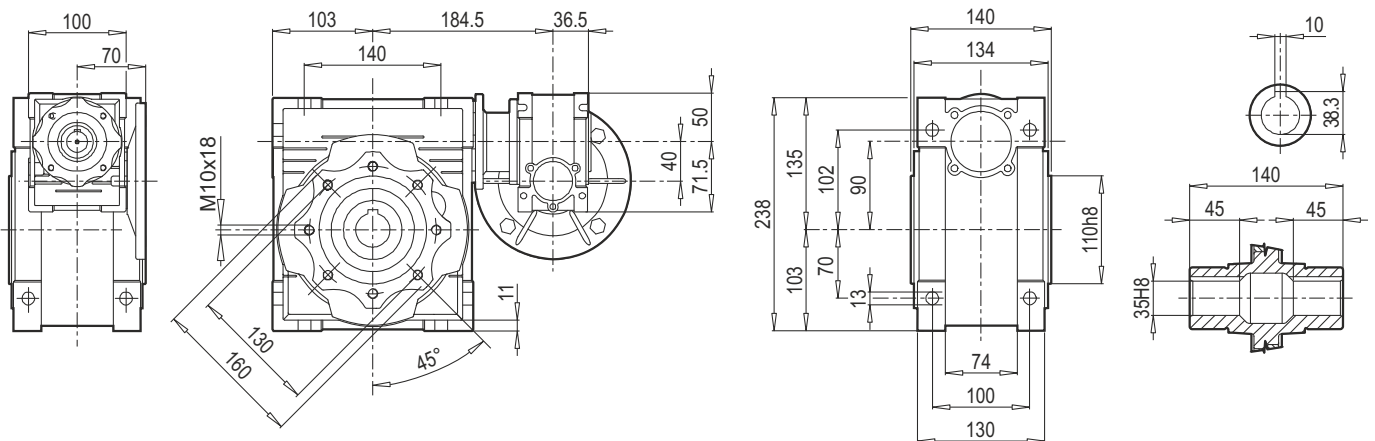

**PMRV 050-105**

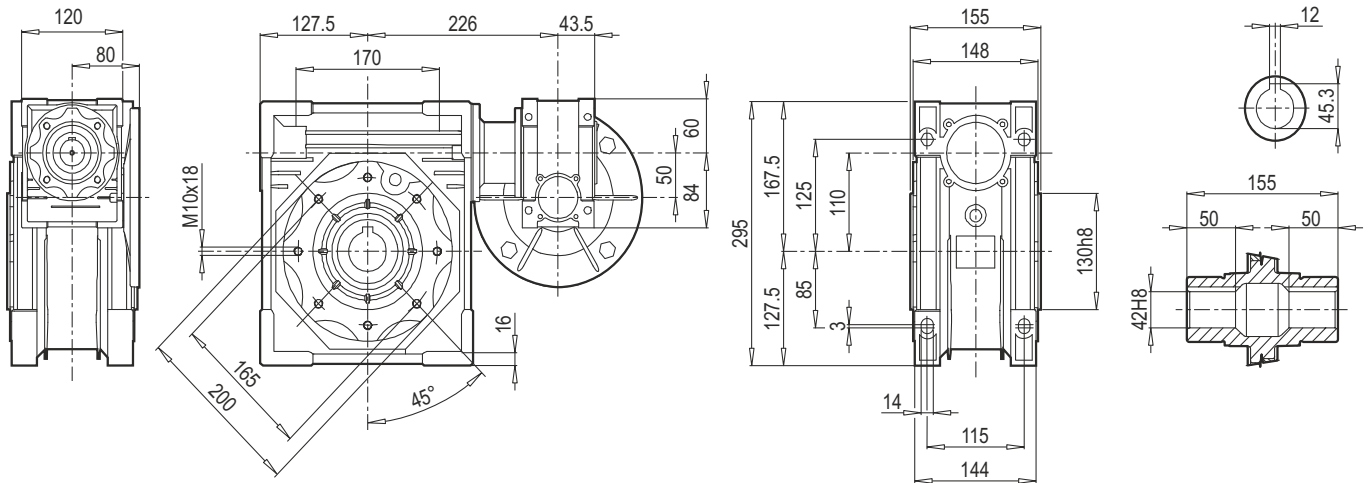

**PMRV 050-110**

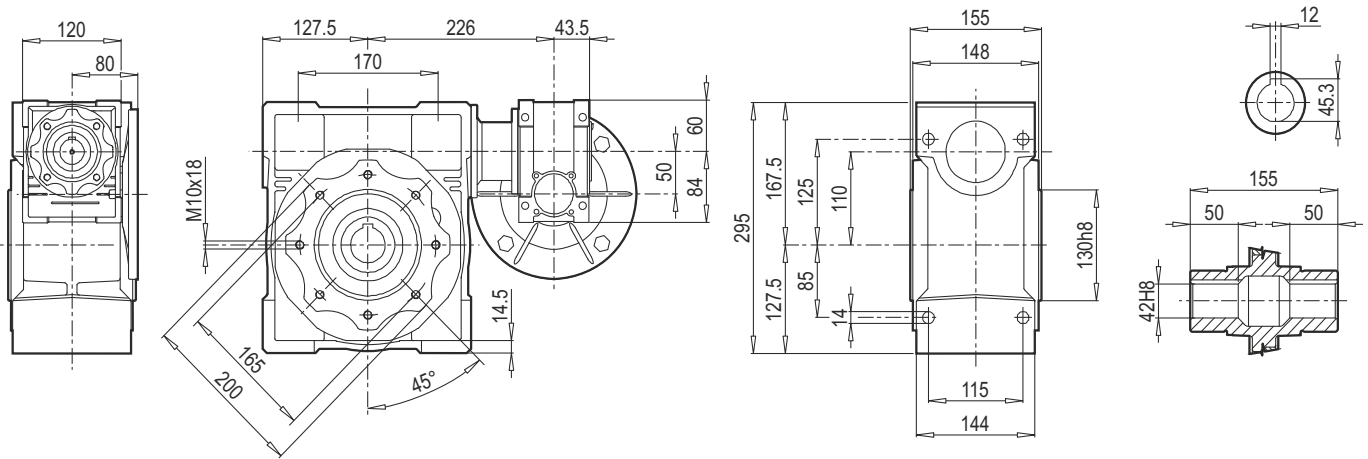

**PMRV 063-130**

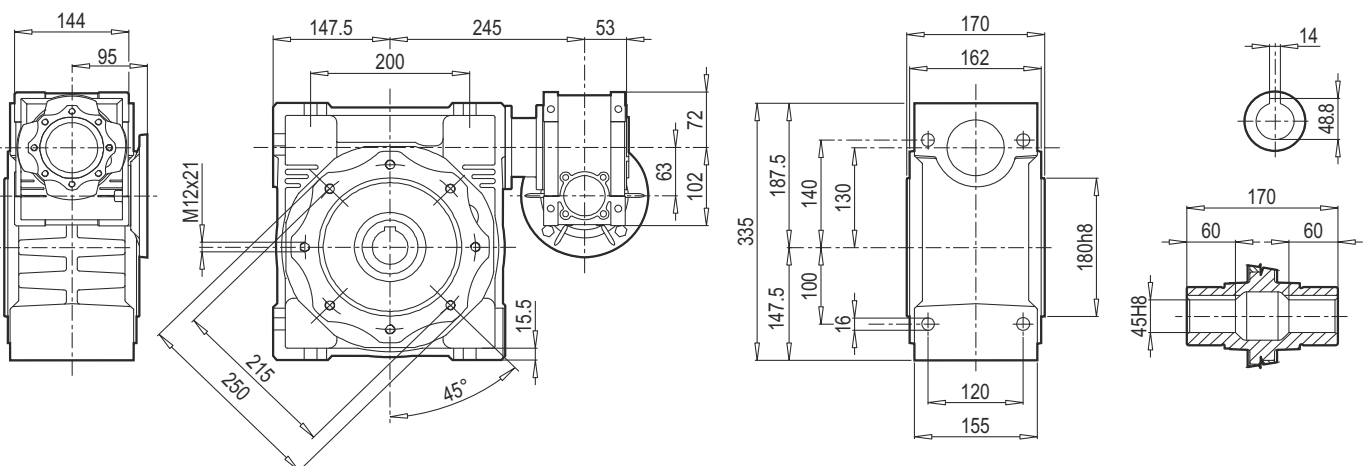

**PMRV 063-150**

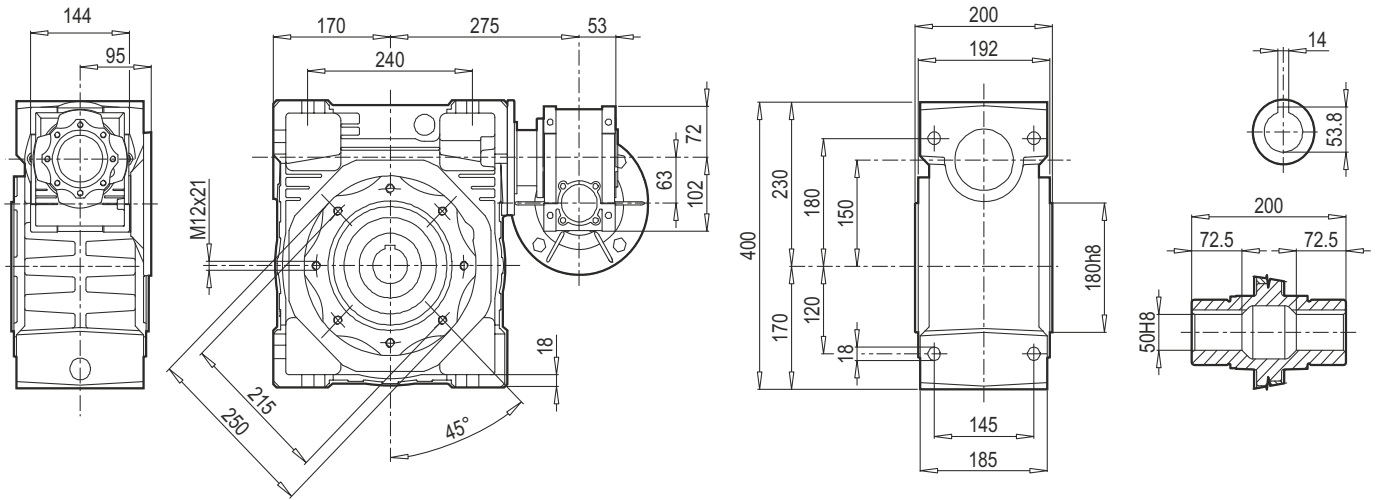

Düşük Hızlı Şaftlar / Low Speed Shafts / Abtriebswellen / Alberi Lenti / Arbres pv / Ejes Lentos

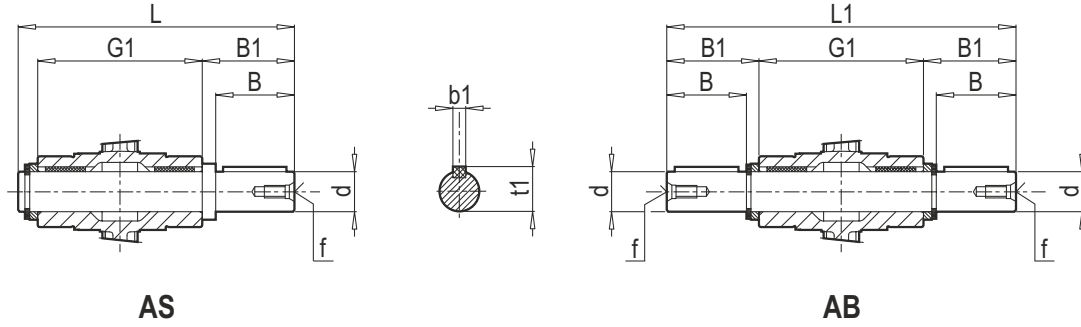

AS

AB

	d	B	B1	G1	L	L1	f	b1	t1
<b>030</b>	14h6	30	32,5	63	102	128	M6	5	16
<b>040</b>	18h6	40	43	78	128	164	M6	6	20,5
<b>050</b>	25h6	50	53,5	92	153	199	M10	8	28
<b>063</b>	25h6	50	53,5	112	173	219	M10	8	28
<b>075</b>	28h6	60	63,5	120	192	247	M10	8	31
<b>090</b>	35h6	80	84,5	140	234	309	M12	10	38
<b>105</b>	42h6	80	84,5	155	249	324	M16	12	45
<b>110</b>	42h6	80	84,5	155	249	324	M16	12	45
<b>130</b>	45h6	80	85	170	265	340	M16	14	48,5
<b>150</b>	50h6	82	87	200	297	374	M16	14	53,5

(..) Sadece talebe bağılı olarak  
(..) Only on request  
(..) Auf Wunsch  
(..) Solo su richiesta  
(..) Seulement sur demande  
(..) Sólo bajo pedido

Kapak / Cover / Deckel / Cappellotto / Capuchon / Tapa

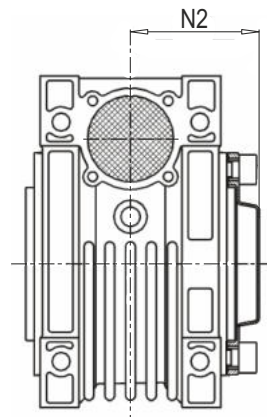

	N2
<b>030</b>	42
<b>040</b>	50
<b>050</b>	58
<b>063</b>	69
<b>075</b>	74
<b>090</b>	86
<b>105</b>	94
<b>110</b>	94
<b>130</b>	102
<b>150</b>	117

Tork Kolu / Torque Arm / Drehmomentstütze / Braccio di reazione / Bras de réaction / Brazo de reacción

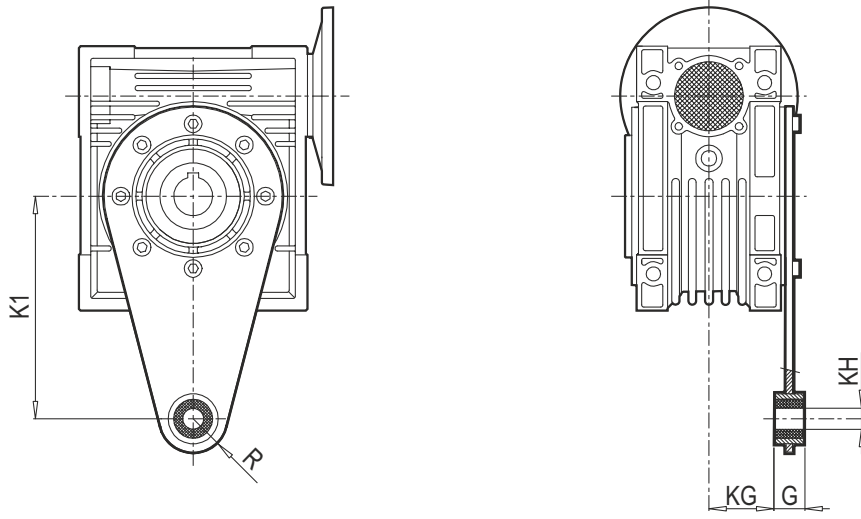

	<b>K1</b>	<b>G</b>	<b>KG</b>	<b>KH</b>	<b>R</b>
<b>030</b>	85	14	24	8	15
<b>040</b>	100	14	31,5	10	18
<b>050</b>	100	14	38,5	10	18
<b>063</b>	150	14	49	10	18
<b>075</b>	200	25	47,5	20	30
<b>090</b>	200	25	57,5	20	30
<b>105</b>	250	30	62	25	35
<b>110</b>	250	30	62	25	35
<b>130</b>	250	30	69	25	35
<b>150</b>	250	30	84	25	35

Ölçüler / Dimensions / Abmessungen / Dimensioni / Encombremets / Dimensiones

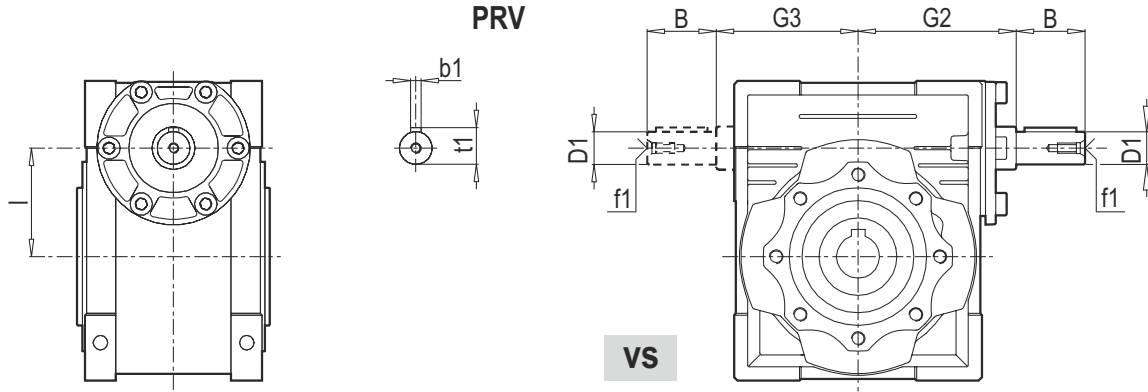

PRV	030	040	050	063	075	090	105	110	130	150
<b>B</b>	20	23	30	40	50	50	60	60	80	80
<b>D1</b>	9 j6	11 j6	14 j6	19 j6	24 j6	24 j6	28 j6	28 j6	30 j6	35 j6
<b>G2</b>	51	60	74	90	105	125	142	142	162	195
<b>G3</b>	45	53	64	75	90	108	135	135	155	175
<b>I</b>	30	40	50	63	75	90	110	110	130	150
<b>b1</b>	3	4	5	6	8	8	8	8	8	10
<b>f1</b>	-	-	M6	M6	M8	M8	M10	M10	M10	M12
<b>t1</b>	10,2	12,5	16	21,5	27	27	31	31	33	38

Ölçüler / Dimensions / Abmessungen / Dimensioni / Encombremets / Dimensiones

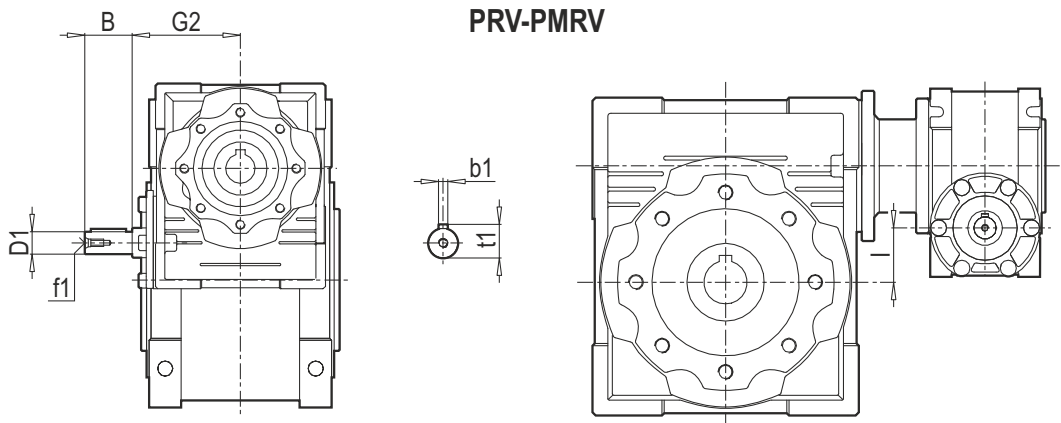

PRV-PMRV	030-040	030-050	030-063	040-075	040-090	050-105	050-110	063-130	063-150
<b>B</b>	20	20	20	23	23	30	30	40	40
<b>D1</b>	9 j6	9 j6	9 j6	11 j6	11 j6	14 j6	14 j6	19 j6	19 j6
<b>G2</b>	51	51	51	60	60	74	74	90	90
<b>I</b>	10	20	33	35	50	60	60	67	87
<b>b1</b>	3	3	3	4	4	5	5	6	6
<b>f1</b>	-	-	-	-	-	M6	M6	M6	M6
<b>t1</b>	10,2	10,2	10,2	12,5	12,5	16	16	21,5	21,5

Eksik verilen gövde büyüklükleri için PMRV ölçüleri ile ilgili çizimlere bakınız.  
For the missing dimensions, please consider the drawing of relevant PMRV size.  
Die nicht angegebenen Maße sind der Maßzeichnung des PMRV der entsprechenden Größe zu entnehmen.  
Per le dimensioni non contemplate fare riferimento al dimensionale PMRV della grandezza relativa.  
Pour les dimensions non spécifiées, nous vous prions de vous référer au dessin PMRV dans la taille désirée.  
Para las cotas no contempladas hacer referencia a las dimensiones PMRV de los tamaños correspondientes.

PAM B5 ÖLÇÜLERİ / DIMENSIONS / ABMESSUNGEN / DIMENSIONI / ENCOMBREMENTS / DIMENSIONES

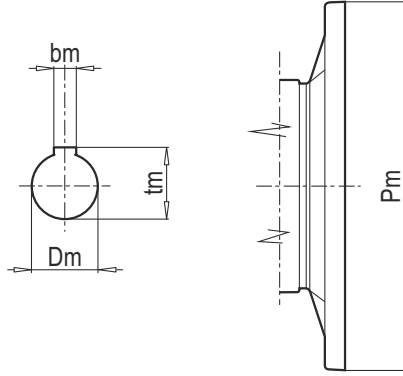

B5	PAM										
	056	063	071	080	090	100	112	132	160	180	200
Pm	120	140	160	200	200	250	250	300	350	350	400
Dm	9	11	14	19	24	28	28	38	42	48	55
bm	3	4	5	6	8	8	8	10	12	14	16
tm	10,4	12,8	16,3	21,8	27,3	31,3	31,3	41,3	45,3	51,8	59,3

PMRV (110 - 130) tm= 40,3 (PAM 132)

PAM B14 ÖLÇÜLERİ / DIMENSIONS / ABMESSUNGEN / DIMENSIONI / ENCOMBREMENTS / DIMENSIONES

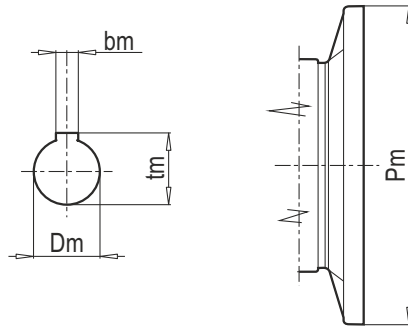

B14	PAM								
	056	063	071	080	090	100	112	132	
Pm	80	90	105	120	140	160	160	200	
Dm	9	11	14	19	24	28	28	38	
bm	3	4	5	6	8	8	8	10	
tm	10,4	12,8	16,3	21,8	27,3	31,3	31,3	41,3	

BOYUTLAR - B5, B35

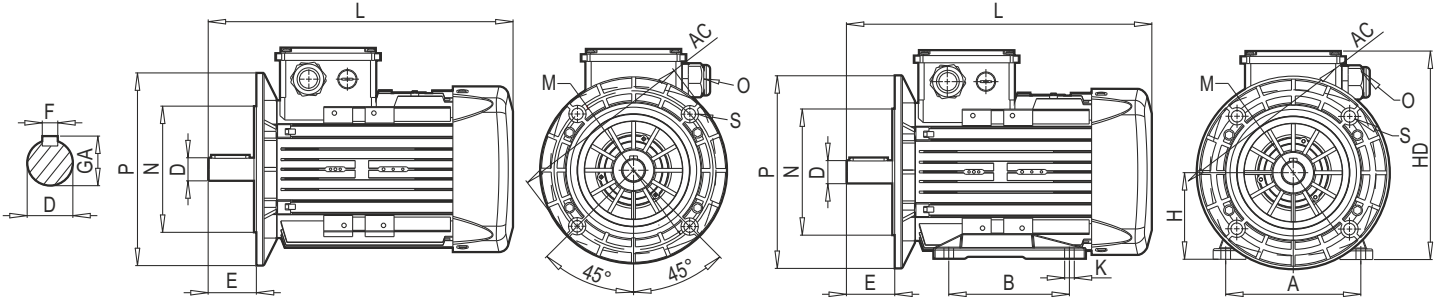

B5 - V1 - V3

B35 - V15 - V35

Güç (kW)	Kutup Sayısı	Motor Tipi	Ana Boyutlar			Ayaklı Motorlar					Mil				Rulman		Keçe		Flanş (FA) (B5)				
			AC	L	O	B	A	H	HD	K	D <sup>(1)</sup>	E	GA	F <sup>(2)</sup>	Kasnak Tarafı	Kasnak Tarafı Aksisi	Kasnak Tarafı	Kasnak Tarafı Aksisi	P	N <sup>(3)</sup>	M	R	S
0.12	4	Q1E63M4A	123	219.5	1*M20	80	100	63	174	7	11	23	12.5	4	6201-2Z	6201-2Z	12*22*7	12*22*7	140	95	115	0	10
	2	Q1E63M2A	123	219.5	1*M20	80	100	63	174	7	11	23	12.5	4	6201-2Z	6201-2Z	12*22*7	12*22*7	140	95	115	0	10
0.18	4	Q1E63M4B	123	219.5	1*M20	80	100	63	174	7	11	23	12.5	4	6201-2Z	6201-2Z	12*22*7	12*22*7	140	95	115	0	10
	6	Q1E71M6A	138	252.5	1*M20	90	112	71	190	7	14	30	16	5	6202-2Z	6202-2Z	15*24*5	15*24*5	160	110	130	0	10
0.25	2	Q1E63M2B	123	219.5	1*M20	80	100	63	174	7	11	23	12.5	4	6201-2Z	6201-2Z	12*22*5	12*22*7	140	95	115	0	10
	4	Q1E71M4A	138	252.5	1*M20	90	112	71	190	7	14	30	16	5	6202-2Z	6202-2Z	15*24*5	15*24*5	160	110	130	0	10
0.37	6	Q1E71M6B	138	252.5	1*M20	90	112	71	190	7	14	30	16	5	6202-2Z	6202-2Z	15*24*5	15*24*5	160	110	130	0	10
	2	Q1E63M2C	123	219.5	1*M20	80	100	63	174	7	11	23	12.5	4	6201-2Z	6201-2Z	12*22*7	12*22*7	140	95	115	0	10
0.55	2	Q1E71M2A	138	252.5	1*M20	90	112	71	190	7	14	30	16	5	6202-2Z	6202-2Z	15*24*5	15*24*5	160	110	130	0	10
	4	Q1E71M4B	138	252.5	1*M20	90	112	71	190	7	14	30	16	5	6202-2Z	6202-2Z	15*24*5	15*24*5	160	110	130	0	10
0.75	6	Q1E80M6A	158	283.5	1*M20	100	125	80	195	10	19	40	21.5	6	6204-2Z	6204-2Z	20*30*7	20*30*7	200	130	165	0	12
	2	Q1E71M2B	138	252.5	1*M20	90	112	71	190	7	14	30	16	5	6202-2Z	6202-2Z	15*24*5	15*24*5	160	110	130	0	10
1.1	4	Q1E71M4C	138	252.5	1*M20	90	112	71	190	7	14	30	16	5	6202-2Z	6202-2Z	15*24*5	15*24*5	160	110	130	0	10
	6	Q1E80M6B	158	283.5	1*M20	100	125	80	195	10	19	40	21.5	6	6204-2Z	6204-2Z	20*30*7	20*30*7	200	130	165	0	12
1.5	2	Q1E71M2C	138	252.5	1*M20	90	112	71	190	7	14	30	16	5	6202-2Z	6202-2Z	15*24*5	15*24*5	160	110	130	0	10
	4	Q1E80M4A	158	283.5	1*M20	100	125	80	195	10	19	40	21.5	6	6204-2Z	6204-2Z	20*30*7	20*30*7	200	130	165	0	12
2.2	6	Q1E90S6A	193	296.5	1*M25	100	140	90	222	10	24	50	27	8	6305-2Z	6205-2Z	25*40*7	25*40*7	200	130	165	0	12
	2	Q1E71M2D	138	252.5	1*M20	90	112	71	190	7	14	30	16	5	6202-2Z	6202-2Z	15*24*5	15*24*5	160	110	130	0	10
3	2	Q1E80M2B	158	283.5	1*M20	100	125	80	195	10	19	40	21.5	6	6204-2Z	6204-2Z	20*30*7	20*30*7	200	130	165	0	12
	4	Q1E80M4C	158	283.5	1*M20	100	125	80	195	10	19	40	21.5	6	6204-2Z	6204-2Z	20*30*7	20*30*7	200	130	165	0	12
1.5	4	Q1E90S4A	193	296.5	1*M25	100	140	90	222	10	24	50	27	8	6305-2Z	6205-2Z	25*40*7	25*40*7	200	130	165	0	12
	6	Q1E90L6B	193	316.5	1*M25	125	140	90	222	10	24	50	27	8	6305-2Z	6205-2Z	25*40*7	25*40*7	200	130	165	0	12
2.2	2	Q1E80M2C	158	283.5	1*M20	100	125	80	195	10	19	40	21.5	6	6204-2Z	6204-2Z	20*30*7	20*30*7	200	130	165	0	12
	4	Q1E80M4D	158	283.5	1*M20	100	125	80	195	10	19	40	21.5	6	6204-2Z	6204-2Z	20*30*7	20*30*7	200	130	165	0	12
3	2	Q1E90S2A	193	296.5	1*M25	100	140	90	222	10	24	50	27	8	6305-2Z	6205-2Z	25*40*7	25*40*7	200	130	165	0	12
	4	Q1E90L4A	193	316.5	1*M25	125	140	90	222	10	24	50	27	8	6305-2Z	6205-2Z	25*40*7	25*40*7	200	130	165	0	12
3	6	Q1E100L6A	217	352	1*M25	140	160	100	241	12	28	60	31	8	6306-2Z	6205-2Z	30*47*7	25*40*7	250	180	215	0	15
	2	Q1E80M2D	158	283.5	1*M20	100	125	80	195	10	19	40	21.5	6	6204-2Z	6204-2Z	20*30*7	20*30*7	200	130	165	0	12
3	2	Q1E90L2A	193	316.5	1*M25	125	140	90	222	10	24	50	27	8	6305-2Z	6205-2Z	25*40*7	25*40*7	200	130	165	0	12
	4	Q1E90L4C	193	316.5	1*M25	125	140	90	222	10	24	50	27	8	6305-2Z	6205-2Z	25*40*7	25*40*7	200	130	165	0	12
3	4	Q1E100L4A	217	352	1*M25	140	160	100	241	12	28	60	31	8	6306-2Z	6205-2Z	30*47*7	25*40*7	250	180	215	0	15
	6	Q1E112M6A	232	395.5	2*M25	140	190	112	261	12	28	60	31	8	6306-2Z	6206-2Z	30*47*7	30*47*7	250	180	215	0	15
3	2	Q1E90L2C	193	316.5	1*M25	125	140	90	222	10	24	50	27	8	6305-2Z	6205-2Z	25*40*7	25*40*7	200	130	165	0	12
	4	Q1E90L4D	193	344.5	1*M25	125	140	90	222	10	24	50	27	8	6305-2Z	6205-2Z	25*40*7	25*40*7	200	130	165	0	12
3	2	Q1E100L2A	217	352	1*M25	140	160	100	241	12	28	60	31	8	6306-2Z	6205-2Z	30*47*7	25*40*7	250	180	215	0	15
	4	Q1E100L4B	217	352	1*M25	140	160	100	241	12	28	60	31	8	6306-2Z	6205-2Z	30*47*7	25*40*7	250	180	215	0	15
3	6	Q1E132S6B	279	440.5	2*M32	140	216	132	314	12	38	80	41	10	6208-2Z	6208-2Z	40*62*10	40*62*10	300	230	265	0	15



**BOYUTLAR - B5, B35**

			Ana Boyutlar			Ayaklı Motorlar					Mil				Rulman		Keçe		Flanş (FA) (B5)				
Güç (kW)	Kutup Sayısı	Motor Tipi	AC	L	O	B	A	H	HD	K	D <sup>(1)</sup>	E	GA	F <sup>(2)</sup>	Kasnak Tarafı	Kasnak Tarafı Aksisi	Kasnak Tarafı	Kasnak Tarafı Aksisi	P	N <sup>(3)</sup>	M	R	S
4	2	Q1E100L2C	217	352	1*M25	140	160	100	241	12	28	60	31	8	6306-2Z	6205-2Z	30*47*7	25*40*7	250	180	215	0	15
	4	Q1E100L4C	217	352	1*M25	140	160	100	241	12	28	60	31	8	6306-2Z	6205-2Z	30*47*7	25*40*7	250	180	215	0	15
	2	Q1E112M2A	232	395.5	2*M25	140	190	112	261	12	28	60	31	8	6306-2Z	6206-2Z	30*47*7	30*47*7	250	180	215	0	15
	4	Q1E112M4B	232	395.5	2*M25	140	190	112	261	12	28	60	31	8	6306-2Z	6206-2Z	30*47*7	30*47*7	250	180	215	0	15
5.5	6	Q1E132M6A	279	475.5	2*M32	178	216	132	314	12	38	80	41	10	6208-2Z	6208-2Z	40*62*10	40*62*10	300	230	265	0	15
	2	Q1E112M2C	232	395.5	2*M25	140	190	112	261	12	28	60	31	8	6306-2Z	6206-2Z	30*47*7	30*47*7	250	180	215	0	15
	4	Q1E112M4C	232	395.5	2*M25	140	190	112	261	12	28	60	31	8	6306-2Z	6206-2Z	30*47*7	30*47*7	250	180	215	0	15
	2	Q1E132S2A	279	440.5	2*M32	140	216	132	314	12	38	80	41	10	6208-2Z	6208-2Z	40*62*10	40*62*10	300	230	265	0	15
7.5	4	Q1E132S4C	279	440.5	2*M32	140	216	132	314	12	38	80	41	10	6208-2Z	6208-2Z	40*62*10	40*62*10	300	230	265	0	15
	6	Q1E132M6B	279	475.5	2*M32	178	216	132	314	12	38	80	41	10	6208-2Z	6208-2Z	40*62*10	40*62*10	300	230	265	0	15
	2	Q1E112M2D	232	395.5	2*M25	140	190	112	261	12	28	60	31	8	6306-2Z	6206-2Z	30*47*7	30*47*7	250	180	215	0	15
	2	Q1E132S2C	279	440.5	2*M32	140	216	132	314	12	38	80	41	10	6208-2Z	6208-2Z	40*62*10	40*62*10	300	230	265	0	15
11	4	Q1E132M4B	279	475.5	2*M32	178	216	132	314	12	38	80	41	10	6208-2Z	6208-2Z	40*62*10	40*62*10	300	230	265	0	15
	6	Q1E160M6B	302	576	2*M32	210	254	160	360	15	42	110	45	12	6309-2Z	6209-2Z	45*72*10	45*72*10	350	250	300	0	19
	2	Q1E132M2A	279	476	2*M32	178	216	132	314	12	38	80	41	10	6208-2Z	6208-2Z	40*62*10	40*62*10	300	230	265	0	15
	4	Q1E132M4C	279	475.5	2*M32	178	216	132	314	12	38	80	41	10	6208-2Z	6208-2Z	40*62*10	40*62*10	300	230	265	0	15
15	2	Q1E160M2B	302	576	2*M32	210	254	160	360	15	42	110	45	12	6309-2Z	6209-2Z	45*72*10	45*72*10	350	250	300	0	19
	4	Q1E160L4A	302	576	2*M32	254	254	160	360	15	42	110	45	12	6309-2Z	6209-2Z	45*72*10	45*72*10	350	250	300	0	19
	6	Q1E160L6B	302	576	2*M32	254	254	160	360	15	42	110	45	12	6309-2Z	6209-2Z	45*72*10	45*72*10	350	250	300	0	19
	6	Q1E180L6A	370	629	2*M40	279	279	180	428	15	48	110	51.5	14	6310-2Z	6310-2Z	50*80*10	50*80*10	350	250	300	0	19

BOYUTLAR - B14a, B34a

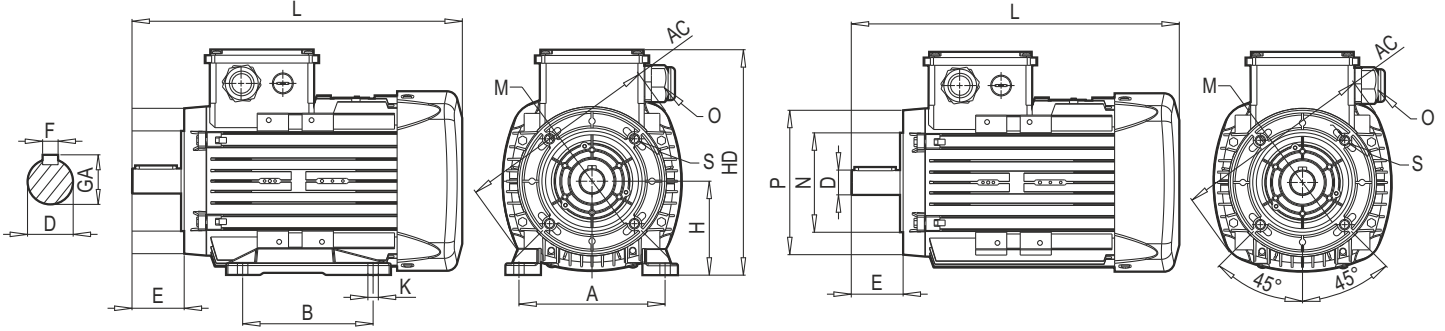

B34 - V17 - V37

B14 - V18 - V19

Güç (kW)	Kutup Sayısı	Motor Tipi	Ana Boyutlar			Ayıklı Motorlar					Mil			Rulman		Keçe		Flanş (FA) (B5)					
			AC	L	O	B	A	H	HD	K	D <sup>(1)</sup>	E	GA	F <sup>(2)</sup>	Kasnak Tarafı	Kasnak Tarafı Aksı	Kasnak Tarafı	Kasnak Tarafı Aksı	P	N <sup>(3)</sup>	M	R	S
0.12	4	Q1E63M4A	123	219.5	1*M20	80	100	63	174	7	11	23	12.5	4	6201-2Z	6201-2Z	12*22*7	12*22*7	90	60	75	0	M5
	2	Q1E63M2A	123	219.5	1*M20	80	100	63	174	7	11	23	12.5	4	6201-2Z	6201-2Z	12*22*7	12*22*7	90	60	75	0	M5
0.18	4	Q1E63M4B	123	219.5	1*M20	80	100	63	174	7	11	23	12.5	4	6201-2Z	6201-2Z	12*22*7	12*22*7	90	60	75	0	M5
	6	Q1E71M6A	138	252.5	1*M20	90	112	71	190	7	14	30	16	5	6202-2Z	6202-2Z	15*24*5	15*24*5	105	70	85	0	M6
0.25	2	Q1E63M2B	123	219.5	1*M20	80	100	63	174	7	11	23	12.5	4	6201-2Z	6201-2Z	12*22*7	12*22*7	90	60	75	0	M5
	4	Q1E71M4A	138	252.5	1*M20	90	112	71	190	7	14	30	16	5	6202-2Z	6202-2Z	15*24*5	15*24*5	105	70	85	0	M6
0.37	6	Q1E71M6B	138	252.5	1*M20	90	112	71	190	7	14	30	16	5	6202-2Z	6202-2Z	15*24*5	15*24*5	105	70	85	0	M6
	2	Q1E63M2C	123	219.5	1*M20	80	100	63	174	7	11	23	12.5	4	6201-2Z	6201-2Z	12*22*7	12*22*7	90	60	75	0	M5
0.55	2	Q1E71M2A	138	252.5	1*M20	90	112	71	190	7	14	30	16	5	6202-2Z	6202-2Z	15*24*5	15*24*5	105	70	85	0	M6
	4	Q1E71M4B	138	252.5	1*M20	90	112	71	190	7	14	30	16	5	6202-2Z	6202-2Z	15*24*5	15*24*5	105	70	85	0	M6
0.75	6	Q1E80M6A	158	283.5	1*M20	100	125	80	195	10	19	40	21.5	6	6204-2Z	6204-2Z	20*30*7	20*30*7	120	80	100	0	M6
	2	Q1E71M2B	138	252.5	1*M20	90	112	71	190	7	14	30	16	5	6202-2Z	6202-2Z	15*24*5	15*24*5	105	70	85	0	M6
1.1	4	Q1E71M4C	138	252.5	1*M20	90	112	71	190	7	14	30	16	5	6202-2Z	6202-2Z	15*24*5	15*24*5	105	70	85	0	M6
	6	Q1E80M6B	158	283.5	1*M20	100	125	80	195	10	19	40	21.5	6	6204-2Z	6204-2Z	20*30*7	20*30*7	120	80	100	0	M6
1.5	2	Q1E80M4A	158	283.5	1*M20	100	125	80	195	10	19	40	21.5	6	6204-2Z	6204-2Z	20*30*7	20*30*7	120	80	100	0	M6
	4	Q1E80M4B	158	283.5	1*M20	100	125	80	195	10	19	40	21.5	6	6204-2Z	6204-2Z	20*30*7	20*30*7	120	80	100	0	M6
2.2	6	Q1E90S6A	193	296.5	1*M25	100	140	90	222	10	24	50	27	8	6305-2Z	6205-2Z	25*40*7	25*40*7	140	95	115	0	M8
	2	Q1E71M2D	138	252.5	1*M20	90	112	71	190	7	14	30	16	5	6202-2Z	6202-2Z	15*24*5	15*24*5	105	70	85	0	M6
3	2	Q1E80M2C	158	283.5	1*M20	100	125	80	195	10	19	40	21.5	6	6204-2Z	6204-2Z	20*30*7	20*30*7	120	80	100	0	M6
	4	Q1E80M4D	158	283.5	1*M20	100	125	80	195	10	19	40	21.5	6	6204-2Z	6204-2Z	20*30*7	20*30*7	120	80	100	0	M6
4	2	Q1E90S2A	193	296.5	1*M25	100	140	90	222	10	24	50	27	8	6305-2Z	6205-2Z	25*40*7	25*40*7	140	95	115	0	M8
	4	Q1E90L4A	193	316.5	1*M25	125	140	90	222	10	24	50	27	8	6305-2Z	6205-2Z	25*40*7	25*40*7	140	95	115	0	M8
5.5	6	Q1E100L6A	217	352	1*M25	140	160	100	241	12	28	60	31	8	6306-2Z	6205-2Z	30*47*7	25*40*7	160	110	130	0	M8
	2	Q1E80M2D	158	283.5	1*M20	100	125	80	195	10	19	40	21.5	6	6204-2Z	6204-2Z	20*30*7	20*30*7	120	80	100	0	M6
7.5	2	Q1E90L2A	193	316.5	1*M25	125	140	90	222	10	24	50	27	8	6305-2Z	6205-2Z	25*40*7	25*40*7	140	95	115	0	M8
	4	Q1E90L4C	193	316.5	1*M25	125	140	90	222	10	24	50	27	8	6305-2Z	6205-2Z	25*40*7	25*40*7	140	95	115	0	M8
11	4	Q1E100L4A	217	352	1*M25	140	160	100	241	12	28	60	31	8	6306-2Z	6205-2Z	30*47*7	25*40*7	160	110	130	0	M8
	6	Q1E112M6A	232	395.5	2*M25	140	190	112	261	12	28	60	31	8	6306-2Z	6206-2Z	30*47*7	30*47*7	160	110	130	0	M8
11	2	Q1E90L2C	193	316.5	1*M25	125	140	90	222	10	24	50	27	8	6305-2Z	6205-2Z	25*40*7	25*40*7	140	95	115	0	M8
	4	Q1E90L4D	193	344.5	1*M25	125	140	90	222	10	24	50	27	8	6305-2Z	6205-2Z	25*40*7	25*40*7	140	95	115	0	M8
11	2	Q1E100L2A	217	352	1*M25	140	160	100	241	12	28	60	31	8	6306-2Z	6205-2Z	30*47*7	25*40*7	160	110	130	0	M8
	4	Q1E100L4B	217	352	1*M25	140	160	100	241	12	28	60	31	8	6306-2Z	6205-2Z	30*47*7	25*40*7	160	110	130	0	M8
11	6	Q1E132S6B	279	440.5	2*M32	140	216	132	314	12	38	80	41	10	6208-2Z	6208-2Z	40*62*10	40*62*10	200	130	165	0	M10
	2	Q1E100L2C	217	352	1*M25	140	160	100	241	12	28	60	31	8	6306-2Z	6205-2Z	30*47*7	25*40*7	160	110	130	0	M8
11	4	Q1E100L4C	217	352	1*M25	140	160	100	241	12	28	60	31	8	6306-2Z	6205-2Z	30*47*7	25*40*7	160	110	130	0	M8
	2	Q1E112M2A	232	395.5	2*M25	140	190	112	261	12	28	60	31	8	6306-2Z	6206-2Z	30*47*7	30*47*7	160	110	130	0	M8
11	4	Q1E112M4B	232	395.5	2*M25	140	190	112	261	12	28	60	31	8	6306-2Z	6206-2Z	30*47*7	30*47*7	160	110	130	0	M8
	6	Q1E132M6A	279	475.5	2*M32	178	216	132	314	12	38	80	41	10	6208-2Z	6208-2Z	40*62*10	40*62*10	200	130	165	0	M10
11	2	Q1E112M2C	232	395.5	2*M25	140	190	112	261	12	28	60	31	8	6306-2Z	6206-2Z	30*47*7	30*47*7	160	110	130	0	M8
	4	Q1E132S2A	279	440.5	2*M32	140	216	132	314	12	38	80	41	10	6208-2Z	6208-2Z	40*62*10	40*62*10	200	130	165	0	M10
11	4	Q1E112M4C	232	395.5	2*M25	140	190	112	261	12	28	60	31	8	6306-2Z	6206-2Z	30*47*7	30*47*7	160	110	130	0	M8
	6	Q1E132S4C	279	440.5	2*M32	140	216	132	314	12	38	80	41	10	6208-2Z	6208-2Z	40*62*10	40*62*10	200	130	165	0	M10
11	2	Q1E132M6B	279	475.5	2*M32	178	216	132	314	12	38	80	41	10	6208-2Z	6208-2Z	40*62*10	40*62*10	200	130	165	0	M10
	4	Q1E112M2D	232	395.5	2*M25	140	190	112	261	12	28	60	31	8	6306-2Z	6206-2Z	30*47*7	30*47*7	160	110	130	0	M8
11	2	Q1E132M2D	232	395.5	2*M25	140	190	112	261	12	28	60	31	8	6306-2Z	6206-2Z	30*47*7	30*47*7	160	110	130	0	M8
	4	Q1E132S2C	279	440.5	2*M32	140	216	132	314	12	38	80	41	10	6208-2Z	6208-2Z	40*62*10	40*62*10	200	130	165	0	M10
11	2	Q1E132M4B	279	475.5	2*M32	178	216	132	314	12	38	80	41	10	6208-2Z	6208-2Z	40*62*10	40*62*10	200	130	165	0	M10
	4	Q1E132M2A	279	476	2*M32	178	216	132	314	12	38	80	41	10	6208-2Z	6208-2Z	40*62*10	40*62*10	200	130	165	0	M10
11	4	Q1E132M4C	279	475.5	2*M32	178	216	132	314	12	38	80	41	10	6208-2Z	6208-2Z	40*62*10	40*62*10	200	130	165	0	M10

(1) Toleranslar 28 mm'ye kadar DIN EN 50347 "j6", 28 mm ve üzeri "k6"

(2) DIN 6885'e göre

(3) Tolerans DIN EN 50347 "j6"

**BOYUTLAR - B14b, B34b**

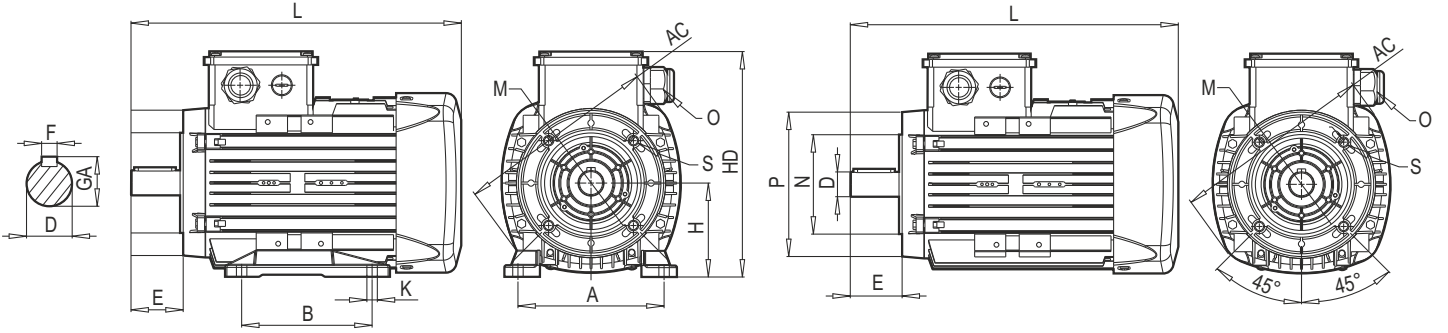

**B34 - V17 - V37**

**B14 - V18 - V19**

Güç (kW)	Kutup Sayısı	Motor Tipi	Ana Boyutlar			Ayaklı Motorlar					Mil				Rulman		Keçe		Flanş (FA) (B5)				
			AC	L	O	B	A	H	HD	K	D <sup>(1)</sup>	E	GA	F <sup>(2)</sup>	Kasnak Tarafı	Kasnak Tarafı Aksı	Kasnak Tarafı	Kasnak Tarafı Aksı	P	N <sup>(3)</sup>	M	R	S
0.12	4	Q1E63M4A	123	219.5	1*M20	80	100	63	174	7	11	23	12.5	4	6201-22	6201-22	12*22*7	12*22*7	120	80	100	0	M6
	2	Q1E63M2A	123	219.5	1*M20	80	100	63	174	7	11	23	12.5	4	6201-22	6201-22	12*22*7	12*22*7	120	80	100	0	M6
0.18	4	Q1E63M4B	123	219.5	1*M20	80	100	63	174	7	11	23	12.5	4	6201-22	6201-22	12*22*7	12*22*7	120	80	100	0	M6
	6	Q1E71M6A	138	252.5	1*M20	90	112	71	190	7	14	30	16	5	6202-22	6202-22	15*24*5	15*24*5	140	95	100	0	M8
0.25	2	Q1E63M2B	123	219.5	1*M20	80	100	63	174	7	11	23	12.5	4	6201-22	6201-22	12*22*7	12*22*7	120	80	100	0	M6
	4	Q1E71M4A	138	252.5	1*M20	90	112	71	190	7	14	30	16	5	6202-22	6202-22	15*24*5	15*24*5	140	95	100	0	M8
0.37	6	Q1E71M6B	138	252.5	1*M20	90	112	71	190	7	14	30	16	5	6202-22	6202-22	15*24*5	15*24*5	140	95	100	0	M8
	2	Q1E63M2C	123	219.5	1*M20	80	100	63	174	7	11	23	12.5	4	6201-22	6201-22	12*22*7	12*22*7	120	80	100	0	M6
	2	Q1E71M2A	138	252.5	1*M20	90	112	71	190	7	14	30	16	5	6202-22	6202-22	15*24*5	15*24*5	140	95	100	0	M8
	4	Q1E71M4B	138	252.5	1*M20	90	112	71	190	7	14	30	16	5	6202-22	6202-22	15*24*5	15*24*5	140	95	100	0	M8
0.55	6	Q1E80M6A	158	283.5	1*M20	100	125	80	195	10	19	40	21.5	6	6204-22	6204-22	20*30*7	20*30*7	160	110	130	0	M8
	2	Q1E71M2B	138	252.5	1*M20	90	112	71	190	7	14	30	16	5	6202-22	6202-22	15*24*5	15*24*5	140	95	115	0	M8
	4	Q1E71M4C	138	252.5	1*M20	90	112	71	190	7	14	30	16	5	6202-22	6202-22	15*24*5	15*24*5	140	95	115	0	M8
	6	Q1E80M4A	158	283.5	1*M20	100	125	80	195	10	19	40	21.5	6	6204-22	6204-22	20*30*7	20*30*7	160	110	130	0	M8
0.75	6	Q1E80M6B	158	283.5	1*M20	100	125	80	195	10	19	40	21.5	6	6204-22	6204-22	20*30*7	20*30*7	160	110	130	0	M8
	2	Q1E71M2C	138	252.5	1*M20	90	112	71	190	7	14	30	16	5	6202-22	6202-22	15*24*5	15*24*5	140	95	115	0	M8
	2	Q1E80M2A	158	283.5	1*M20	100	125	80	195	10	19	40	21.5	6	6204-22	6204-22	20*30*7	20*30*7	160	110	130	0	M8
	4	Q1E80M4B	158	283.5	1*M20	100	125	80	195	10	19	40	21.5	6	6204-22	6204-22	20*30*7	20*30*7	160	110	130	0	M8
1.1	6	Q1E90S6A	193	296.5	1*M25	100	140	90	222	10	24	50	27	8	6305-22	6205-22	25*40*7	25*40*7	160	110	130	0	M8
	2	Q1E71M2D	138	252.5	1*M20	90	112	71	190	7	14	30	16	5	6202-22	6202-22	15*24*5	15*24*5	140	95	115	0	M8
	2	Q1E80M2B	158	283.5	1*M20	100	125	80	195	10	19	40	21.5	6	6204-22	6204-22	20*30*7	20*30*7	160	110	130	0	M8
	4	Q1E80M4C	158	283.5	1*M20	100	125	80	195	10	19	40	21.5	6	6204-22	6204-22	20*30*7	20*30*7	160	110	130	0	M8
1.5	4	Q1E90S4A	193	296.5	1*M25	100	140	90	222	10	24	50	27	8	6305-22	6205-22	25*40*7	25*40*7	160	110	130	0	M8
	6	Q1E90L6B	193	316.5	1*M25	125	140	90	222	10	24	50	27	8	6305-22	6205-22	25*40*7	25*40*7	160	110	130	0	M8
	2	Q1E80M2C	158	283.5	1*M20	100	125	80	195	10	19	40	21.5	6	6204-22	6204-22	20*30*7	20*30*7	160	110	130	0	M8
	4	Q1E80M4D	158	283.5	1*M20	100	125	80	195	10	19	40	21.5	6	6204-22	6204-22	20*30*7	20*30*7	160	110	130	0	M8
2.2	2	Q1E90S2A	193	296.5	1*M25	100	140	90	222	10	24	50	27	8	6305-22	6205-22	25*40*7	25*40*7	160	110	130	0	M8
	4	Q1E90L4A	193	316.5	1*M25	125	140	90	222	10	24	50	27	8	6305-22	6205-22	25*40*7	25*40*7	160	110	130	0	M8
	6	Q1E100L6A	217	352	1*M25	140	160	100	241	12	28	60	31	8	6306-22	6205-22	30*47*7	25*40*7	200	130	165	0	M10
	2	Q1E80M2D	158	283.5	1*M20	100	125	80	195	10	19	40	21.5	6	6204-22	6204-22	20*30*7	20*30*7	160	110	130	0	M8
3	2	Q1E90L2A	193	316.5	1*M25	125	140	90	222	10	24	50	27	8	6305-22	6205-22	25*40*7	25*40*7	160	110	130	0	M8
	4	Q1E90L4C	193	316.5	1*M25	125	140	90	222	10	24	50	27	8	6305-22	6205-22	25*40*7	25*40*7	160	110	130	0	M8
	4	Q1E100L4A	217	352	1*M25	140	160	100	241	12	28	60	31	8	6306-22	6205-22	30*47*7	25*40*7	200	130	165	0	M10
	6	Q1E112M6A	232	395.5	2*M25	140	190	112	261	12	28	60	31	8	6306-22	6206-22	30*47*7	30*47*7	200	130	165	0	M10
4	2	Q1E90L2C	193	316.5	1*M25	125	140	90	222	10	24	50	27	8	6305-22	6205-22	25*40*7	25*40*7	160	110	130	0	M8
	4	Q1E90L4D	193	344.5	1*M25	125	140	90	222	10	24	50	27	8	6305-22	6205-22	25*40*7	25*40*7	160	110	130	0	M8
	2	Q1E100L2A	217	352	1*M25	140	160	100	241	12	28	60	31	8	6306-22	6205-22	30*47*7	25*40*7	200	130	165	0	M10
	4	Q1E100L4B	217	352	1*M25	140	160	100	241	12	28	60	31	8	6306-22	6205-22	30*47*7	25*40*7	200	130	165	0	M10
5.5	6	Q1E132S6B	279	440.5	2*M32	140	216	132	314	12	38	80	41	10	6208-22	6208-22	40*62*10	40*62*10	250	180	215	0	M12 veya 15
	2	Q1E100L2C	217	352	1*M25	140	160	100	241	12	28	60	31	8	6306-22	6205-22	30*47*7	25*40*7	200	130	165	0	M10
	4	Q1E100L4C	217	352	1*M25	140	160	100	241	12	28	60	31	8	6306-22	6205-22	30*47*7	25*40*7	200	130	165	0	M10
	2	Q1E112M2A	232	395.5	2*M25	140	190	112	261	12	28	60	31	8	6306-22	6206-22	30*47*7	30*47*7	200	130	165	0	M10
	4	Q1E112M4B	232	395.5	2*M25	140	190	112	261	12	28	60	31	8	6306-22	6206-22	30*47*7	30*47*7	200	130	165	0	M10
	6	Q1E132M6A	279	475.5	2*M32	178	216	132	314	12	38	80	41	10	6208-22	6208-22	40*62*10	40*62*10	250	180	215	0	M12 veya 15
7.5	2	Q1E112M2C	232	395.5	2*M25	140	190	112	261	12	28	60	31	8	6306-22	6206-22	30*47*7	30*47*7	200	130	165	0	M10
	2	Q1E132S2A	279	440.5	2*M32	140	216	132	314	12	38	80	41	10	6208-22	6208-22	40*62*10	40*62*10	250	180	215	0	M12 veya 15
	4	Q1E112M4C	232	395.5	2*M25	140	190	112	261	12	28	60	31	8	6306-22	6206-22	30*47*7	30*47*7	200	130	165	0	M10
	4	Q1E132S4C	279	440.5	2*M32	140	216	132	314	12	38	80	41	10	6208-22	6208-22	40*62*10	40*62*10	250	180	215	0	M12 veya 15
11	6	Q1E132M6B	279	475.5	2*M32	178	216	132	314	12	38	80	41	10	6208-22	6208-22	40*62*10	40*62*10	250	180	215	0	M12 veya 15
	2	Q1E112M2D	232	395.5	2*M25	140	190	112	261	12	28	60	31	8	6306-22	6206-22	30*47*7	30*47*7	200	130	165	0	M10
	2	Q1E112M2D	232	395.5	2*M25	140	190	112	261	12	28	60	31										

TR

**TORK LİMİTLİ SONSUZ VİDA  
 REDÜKTÖRLÜ MOTORLAR.**

EN

**WORM GEARMOTORS AND REDUCERS  
 WITH TORQUE LIMITER.**

DE

**GETRIEBEMOTOREN UND SCHNECKEN-  
 GETRIEBE MIT DREHMOMENTBEGRENZER**

## PMRL



### PMRL - Özellikler

Yağ banyosu içindeki tork sınırlayıcısı 050-063-075-090 gövde büyüklükleri için tasarlanmıştır. Bu cihaz aşırı düzeyde yüklemelerde dişli kutusunu ve güç aktarım elemanlarını etkileyebilecek durumlardan korunmayı sağlar. Gerekirse, kilit somunu gevşeterek geri dönme riskini ortadan kaldırır.

### Özellikleri

- Harici ölçüleri tork sınırlayıcısız olarak kullanılan versiyonla aynıdır.
- Montaj işleminde bir değişiklik yoktur.
- Harici bir halka somunla kayma torku kolaylıkla ayarlanabilir.
- Kayma elemanları bakım gerektirmez.
- Fonksiyonel özellikleri standart versiyonla aynıdır.
- Standart redüktörlerin delik mili çapına göre değişiklik göstermez.

### Tork Ayarlaması

Tork ayarı katalogta anlatıldığı gibi montaj sırasında nominal torkun %80 değerinde yapılır. Bu tork sürtünmeyle iletilir, ayarlama değerini birçok faktör etkileyebilir; bunlardan bazıları şöyledir: ısı-çalışma koşulları, titreşim vb. bununla beraber tork limitinin uygulama gerekliliklerine uygun olarak dişli kutusunu makineye yerleştirirken ayarlanması tavsiye edilir.

### PMRL - Features

The torque limiter, in oil bath, is designed for sizes 050-063-075-090. The device assures the protection of the transmission from accidental high overloads which could damage the gearbox and the power transmission components. If necessary, it prevents reversing conditions of the worm gear unit by opportunely loosening the lock nut.

### Features

- External dimensions are almost the same as the version without torque limiter.
- No difference of the mountings.
- No difference of the hollow output shaft diameter with respect to the standard gearbox.
- The slipping torque can be easily adjusted by means of an external ring nut.
- No maintenance required on slipping components.
- Functional features are the same as standard version.

### Torque adjustment

The adjustment is carried out during assembly at about 80% of the nominal torque reported in the catalogue. This torque is transmitted by friction and so many factors could influence the adjustment value, like: temperature, running-in, vibrations, etc., therefore it is advised to adjust the torque limit by means of the lock nut when installing the gearbox on the machine, in accordance to application requirements.

### PMRL - Eigenschaften

Der Drehmomentbegrenzer mit im Ölbad laufender Kupplung wird bei den Baugrößen 050-063-075-090 empfohlen. Dieses Sicherheitselement gewährleistet den Schutz des Getriebes und der mit diesem verbundenen mechanischen Bauteilen vor unvorhergesehenen Überlastungen. Er verhindert wenn es notwendig ist den Rückwärtslauf des Schenckgetriebes durch Ausrücken eines Einstellringes.

### Eigenschaften

- Keine veränderten Abmessungen mit Drehmomentbegrenzer gegenüber der Standardvariante.
- Keine Veränderung bei den Befestigungsmaßen des Getriebes.
- Ausgangshohlwelle ohne Veränderung des Durchmessers gegenüber der Standardausführung.
- Drehmoment der Rutschkupplung ist von außen am Getriebe leicht über einen Ring einstellbar.
- Eine Wartung der Rutschkupplung ist nicht erforderlich.
- Unveränderte Funktionalität gegenüber den Standardgetrieben.

### Einstellung des Drehmomentes

Das Getriebe wird werksseitig auf ca. 80% des im kataloges angegebenen Nominaldrehmomentes eingestellt. Da es sich um eine Übertragung durch Reibung handelt können verschiedene Faktoren den Einstellwert beeinflussen: - Temperatur, Einlaufen der Bauteile, Vibrationen usw. Daher wird empfohlen die Drehmomentbegrenzung mittels Ringes während des Einbaues in die Maschine auf die wirkliche Anforderung hin zu überprüfen und dementsprechend einzustellen.

**TR** MOTORIDUTTORI E RIDUTTORI A VITE  
SENZA FINE CON LIMITATORE DI COPPIA.

**EN** MOTORÉDUCTEURS ET RÉDUCTEUR À VIS  
SANS FIN AVEC LIMITEUR DE COUPLE

**DE** MOTORREDUCTORES Y REDUCTORES DE  
SINFÍN CON LÍMITADOR DE PAR.

## PMRL



### PMRL - Caratteristiche

Il limitatore di coppia con frizione in bagno d'olio viene proposto sulle grandezze 050-063-075-090. Il dispositivo assicura la protezione del riduttore stesso e degli organi meccanici ad esso collegati da sovraccarichi imprevisti. Elimina, quando è necessario, le condizioni di irreversibilità del gruppo vite senza fine allentando opportunamente la ghiera di taratura.

### Caratteristiche

- Limitato ingombro aggiuntivo rispetto alla versione priva di limitatore di coppia.
- Nessuna variazione sulle dimensioni di fissaggio del riduttore.
- Albero cavo in uscita senza variazioni di diametro rispetto alla versione standard.
- Coppia di slittamento facilmente regolabile dall'esterno del riduttore tramite ghiera.
- Nessuna manutenzione sugli organi soggetti a slittamento.
- Inalterate le caratteristiche funzionali rispetto ai corrispondenti gruppi standard.

### Regolazione della coppia

Il gruppo viene tarato all'atto del montaggio a circa l'80% della coppia nominale di catalogo. Trattandosi però di trasmissione funzionante per attrito, diversi sono i fattori che possono influenzare il valore di taratura: temperatura, rodaggio, presenza di vibrazioni, ecc. pertanto si consiglia, all'atto dell'installazione sulla macchina, di tarare il limite di coppia tramite la ghiera in base alle reali esigenze dell'applicazione.

### PMRL - Caracteristiques

Le limiteur de couple à friction à bain d'huile peut être proposé pour les grandeurs 050-063-075-090. Le dispositif assure la protection, du réducteur même et des organes mécaniques montés sur le réducteur, contre des surcharges imprévisibles. Il élimine, quand cela est nécessaire, la condition d'irréversibilité du groupe à vis sans fin, en desserrant de façon appropriée l'écrou de tarage.

### Caracteristiques

- Encombrement supplémentaire très réduit par rapport à la version standard.
- Aucune variation sur les dimensions de fixation du réducteur.
- Arbre creux en sortie identique en diamètre à la version standard.
- Couple de friction facilement réglable à l'extérieur du réducteur par l'intermédiaire de l'écrou.
- Aucun entretien sur les organes en friction.
- Aucun changement sur les caractéristiques fonctionnelles par rapport au groupe standard.

### Reglage du couple

Le groupe est réglé en usine sur une valeur égale à 80% à peu près du couple nominal du catalogue. Puisqu'il s'agit d'une transmission fonctionnant par friction divers facteurs peuvent influencer la valeur de tarage: température, rodage, présence de vibrations, etc...  
Donc, nous recommandons au moment de l'installation sur la machine, de tarer le limiteur de couple par l'intermédiaire de l'écrou en fonction de l'application.

### PMRL - Características

El limitador de par con embrague en baño de aceite se monta en los tamaños 050-063-075 y 090. Este dispositivo asegura la protección del reductor y de la máquina ante sobrecargas imprevistas. Elimina, cuando se precise, la irreversibilidad del reductor sinfín aflojando convenientemente la tuerca de regulación.

### Características

- Reducido aumento de dimensiones respecto a la versión sin limitador de par.
- Ninguna variación en las dimensiones de fijación del reductor.
- Eje hueco de salida sin variación de diámetro respecto a la versión normal.
- Par tursor del limitador fácilmente regulable desde el exterior del reductor mediante tuerca.
- Elementos de fricción, sin mantenimiento.
- Características de funcionamiento inalteradas respecto a la versión normal.

### Regulación del par

El limitador queda tarado aproximadamente al 80% del par nominal del reductor durante el montaje. Por tratarse de una transmisión que funciona por rozamiento, los factores que pueden influir sobre el par de regulación son los siguientes: temperatura, rodaje, vibraciones, etc. Por ello se recomienda regular el par del limitador durante el montaje en la máquina en función de las exigencias reales de la aplicación.

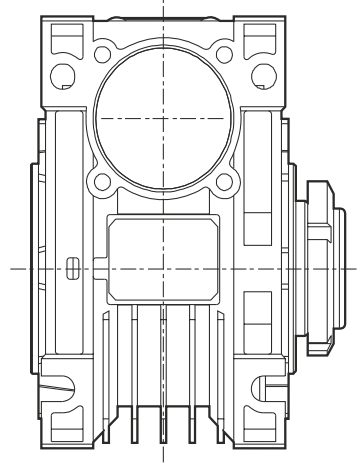

D

Tork sınırlayıcısı D pozisyonunda verilir.  
The torque limiter is supplied in D position.  
Die werksseitige Einstellung der Rutschkupplung entspricht der Position D.  
Il limitatore di coppia viene fornito con montaggio in posizione D.  
Les limiteurs de couple sont fournis avec montage en position D.  
El limitador de par se suministra con montaje en posición D.

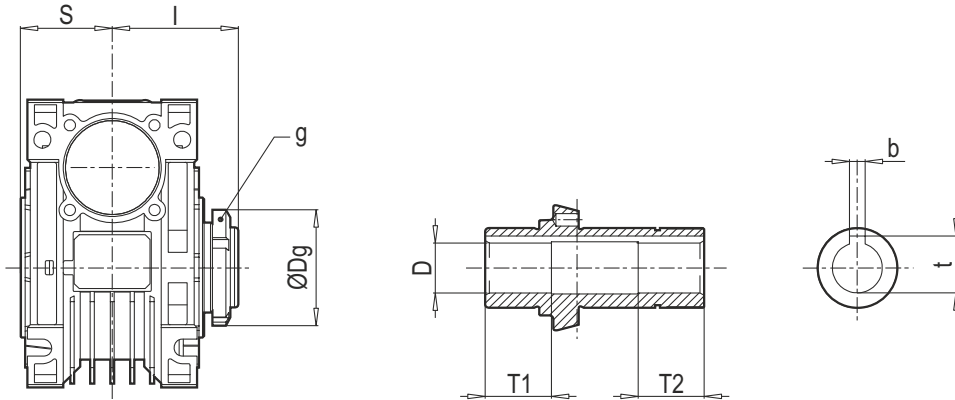

	050	063	075	090
I	63,5	74	78,5	89,5
S	46	56	60	70
Dg	56	62	68	80
g	M40x1,5	M45x1,5	M50x1,5	M60x2
b	8	8	8	10
t	28,3	28,3	31,3	38,3
D	Ø25	Ø25	Ø28	Ø35
T1	33	37	40	45
T2	33	37	40	45

Eksik gövde büyüklükleri için geçerli olan PMRV ölçüleri çizimine bakınız.  
For the missing dimensions, please consider the drawing of relevant PMRV size.  
Die nicht angegebenen Maße sind der Maßzeichnung des PMRV der entsprechenden Größe zu entnehmen.  
Per le dimensioni non contemplate fare riferimento al dimensionale PMRV della grandezza relativa.  
Pour les dimensions non spécifiées, nous vous prions de vous référer au dessin PMRV dans la taille désirée.  
Para las cotas no contempladas hacer referencia a las dimensiones PMRV de los tamaños correspondientes.



A large area of the page is filled with horizontal dotted lines, providing a template for writing or drawing.

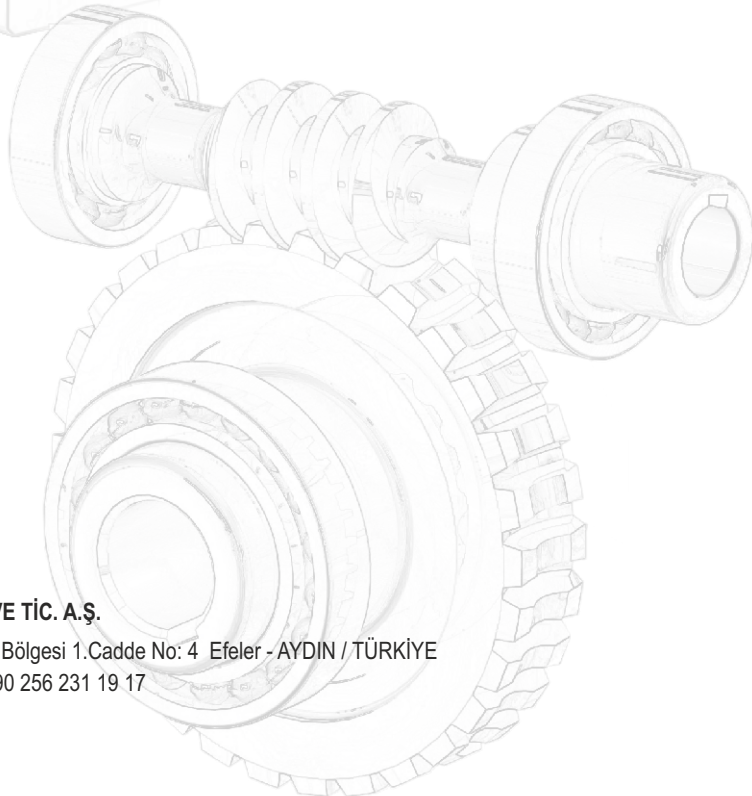
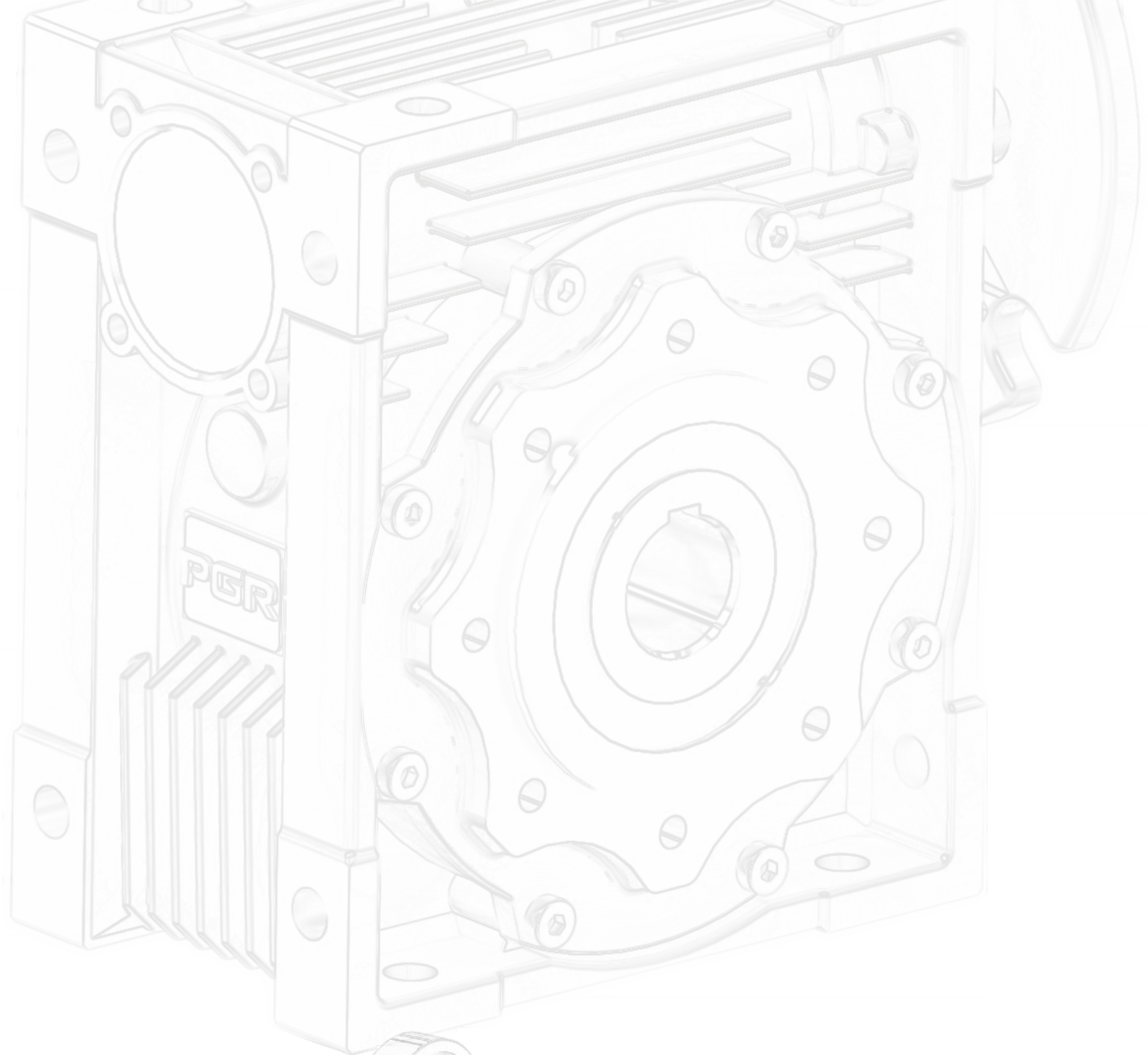

**PGR**<sup>®</sup>  
DRIVE TECHNOLOGIES

**POLAT GROUP REDÜKTÖR SAN. VE TİC. A.Ş.**

Ata Mahallesi Astim Organize Sanayi Bölgesi 1.Cadde No: 4 Efeler - AYDIN / TÜRKİYE

Tel: +90 256 231 19 12 (Pbx) Fax: +90 256 231 19 17

info@pgr.com.tr - www.pgr.com.tr

